

A Dissertation

entitled

Implementation of Scientific Community Laboratories and Their Effect on Student
Conceptual Learning, Attitudes, and Understanding of Uncertainty

by

Adam Lark

Submitted to the Graduate Faculty as partial fulfillment of the requirements for the
Doctor of Philosophy Degree in Physics

Dr. Lawrence Anderson-Huang, Committee Chair

Dr. Rebecca Schneider, Committee Member

Dr. Rick Irving, Committee Member

Dr. Song Cheng, Committee Member

Dr. Jon Bjorkman, Committee Member

Dr. Patricia R. Komuniecki, Dean
College of Graduate Studies

The University of Toledo
May 2014

Copyright 2014, Adam Christopher Lark

This document is copyrighted material. Under copyright law, no parts of this document may be reproduced without the expressed permission of the author.

An Abstract of
Implementation of Scientific Community Laboratories and Their Effect on Student
Conceptual Learning, Attitudes, and Understanding of Uncertainty

by

Adam Lark

Submitted to the Graduate Faculty as partial fulfillment of the requirements for the
Doctor of Philosophy Degree in Physics

The University of Toledo

May 2014

Scientific Community Laboratories, developed by The University of Maryland, have shown initial promise as laboratories meant to emulate the practice of doing physics. These laboratories have been re-created by incorporating their design elements with the University of Toledo course structure and resources. The laboratories have been titled the *Scientific Learning Community* (SLC) Laboratories. A comparative study between these SLC laboratories and the University of Toledo physics department's traditional laboratories was executed during the fall 2012 semester on first semester calculus-based physics students. Three tests were executed as pre-test and post-tests to capture the change in students' concept knowledge, attitudes, and understanding of uncertainty. The Force Concept Inventory (FCI) was used to evaluate students' conceptual changes through the semester and average normalized gains were compared between both traditional and SLC laboratories. The Colorado Learning Attitudes about Science Survey for Experimental Physics (E-CLASS) was conducted to elucidate students' change in attitudes through the course of each laboratory. Finally, interviews regarding data analysis and uncertainty were transcribed and coded to track changes in the way students

understand uncertainty and data analysis in experimental physics after their participation in both laboratory type. Students in the SLC laboratories showed a notable increase in conceptual knowledge and attitudes when compared to traditional laboratories. SLC students' understanding of uncertainty showed most improvement, diverging completely from students in the traditional laboratories, who declined throughout the semester.

This thesis is dedicated to my wife and children: Linda, Sagan, and Aria whose love carried me through this arduous process. I see a great life for all of us in our future. Also, my father, who in death gave me the strength I needed to push forward with my life. Lastly, to my Mother and my Uncle Matt Lark, who when I was ready to give up would always help me back on my path. I could not have done any of this without all of you.

Acknowledgements

Thank you to Dr. Lawrence Anderson for supporting this endeavor and supporting physics education research within the physics department. Also, thank you to Dr. Schneider for supporting our research and keeping us pointed in the right direction. Dr. Kathy Shan for paving the path and helping me walk it. Lastly, thank you to Michelle Deady, Dr. Richard Irving, and Dr. Song Cheng for helping me and allowing me to execute initial versions of the Scientific Learning Community Laboratory. You have all left your mark on this work, and your assistance has been greatly appreciated.

Table of Contents

Abstract.....	iii
Acknowledgements.....	vi
Table of Contents.....	vii
List of Tables.....	xi
List of Figures.....	xii
List of Abbreviations.....	xiii
List of Symbols.....	xiv
1 Problem Statement.....	1
1.1 Purpose Statement.....	4
1.2 Research Questions.....	5
2 Literature Review.....	7
2.1 Learning Physics.....	7
2.1.1 Conceptual Learning.....	8
2.1.2 Attitudes.....	8
2.1.3 Connection between attitudes and conceptual learning.....	9
2.1.4 Procedural Learning.....	10
2.2 Importance of Laboratories in Introductory Physics.....	10
2.3 Traditional Laboratories.....	12
2.3.1 Realtime Physics.....	13

2.4	Discovery-Based Laboratories.....	15
2.5	Scientific Community Laboratory	16
2.5.1	Frames.....	16
2.5.2	Epistemologies.....	17
2.5.3	Design of Scientific Community Laboratories	19
2.5.4	Research Results of Scientific Community Labs.....	20
3	Methods Review	22
3.1	Physics Concept Tests.....	22
3.1.1	Mechanics Diagnostic Test.....	22
3.1.2	Force Concept Inventory.....	23
3.1.3	Force and Motion Concept Evaluation	25
3.2	Attitude Surveys.....	26
3.2.1	Views about Science Survey.....	27
3.2.2	Maryland Physics Expectations Survey.....	27
3.2.3	Colorado Learning Attitudes about Science Survey	28
3.2.4	CLASS for Experimental Physics.....	29
3.3	Measuring Student Understanding of Uncertainty	29
4	Methods.....	34
4.1	Background.....	34
4.1.1	Physics 2130 Course Description	34
4.1.2	Laboratory Demographics	35
4.1.3	Traditional Laboratories.....	39
4.1.4	Scientific Learning Community Laboratories	42

4.2	Instruments.....	47
4.2.1	Conceptual Knowledge.....	48
4.2.2	Understanding of Uncertainty.....	49
4.2.3	Attitudes	51
4.3	Data Analysis	51
4.3.1	Conceptual knowledge.....	51
4.3.2	Understanding of Uncertainty.....	52
4.3.3	Attitudes.....	55
4.3.4	Statistical Significance.....	56
4.3.5	Correlations.....	57
5	Results.....	58
5.1	Force Concept Inventory.....	58
5.2	Uncertainty Interviews.....	59
5.3	E-CLASS Survey	64
5.4	Correlations.....	74
5.5	Statistical Significance.....	75
6	Discussion.....	77
6.1	Conceptual Gains	77
6.2	Uncertainty Interviews.....	79
6.3	Attitude Changes.....	82
6.4	Correlations.....	84
6.5	Limitations	85
6.5.1	Sample Size.....	85

6.5.2 Self-Selection.....	86
6.5.3 Teacher Effect.....	86
6.5.4 Researcher Effect	87
6.6 Implications.....	88
6.7 Future Research	89
6.8 Conclusion	90
References.....	93
A Scientific Learning Community Laboratory Manual.....	99
B Demographic Survey	148
C Uncertainty Interview 1	150
D Written Interview 1	153
E Uncertainty Interview 2	158
F Written Interview 2.....	161
G Uncertainty Interview 3	166

List of Tables

4.1	The number of students who participated in the pre-test, post-test and both the pre-test and post-test of the Force Concept Inventory.	35
4.2	The number of students who participated in the pre-test, post-test and both the pre-test and post-test of the E-CLASS.....	36
4.3	The number of students who participated in oral or written interviews, for interview 1, interview 2, and interview 3 of the uncertainty interviews.....	36
4.4	Demographic Survey Results describing number of participants by gender, age, year in school, previous physics experience, major, and ethnicity.....	37
4.5	Lubben Level Coding Scheme for Interviews Analysis	53
5.1	Summary of FCI Scores and Hake Number of Traditional and SLC Labs	59
5.2	Lubben Level between SLC and Traditional laboratories	59
5.3	E-CLASS expert-like thinking regarding student opinions of themselves.....	65
5.4	E-CLASS expert-like thinking regarding student opinions of a physicist.....	65
5.5	Fraction of expert-like thinking for each question in the E-CLASS survey for the traditional laboratory.....	68
5.6	Fraction of expert-like thinking for each question in the E-CLASS survey for the SLC laboratory.....	70
5.7	Paired <i>t-test</i> results between pre-test and post-test for the FCI and E-CLASS.....	76

List of Figures

4-1	Summary of the Demographics of SLC and traditional laboratory sections	38
5-1	Average Lubben level from each uncertainty interview.....	60
5-2	Traditional laboratory correlation between students' attitudes and their opinion of physicists' attitudes.....	66
5-3	SLC laboratory correlation between students' attitudes and their opinion of physicists' attitudes.....	67
5-4	Correlation between physics conceptual knowledge and understanding of uncertainty.....	74
5-5	Correlation between student attitudes and understanding of uncertainty.	75

List of Abbreviations

CLASS.....	Colorado Learning Attitudes about Science Survey
CSEM.....	Conceptual Survey of Electricity and Magnetism
EBAPS.....	Epistemological Beliefs Assessment for Physical Science
E-CLASS.....	Colorado Learning Attitudes about Science Survey for Experimental Physics
FCI.....	Force Concept Inventory
FMCE	Force and Motion Concept Evaluation
MBT.....	Mechanics Baseline Test
MDT.....	Mechanics Diagnostic Test
MPEX.....	Maryland Physics Expectations Survey
PCAST.....	President's Council of Advisors on Science and Technology
SCL.....	Scientific Community Laboratory
SLC.....	Scientific Learning Community
STEM.....	Science, Technology, Engineering, and Mathematics
TA.....	Teaching Assistant
VASS.....	Views about Science Survey

List of Symbols

σStandard Deviation

gNormalized Gain

$\langle g \rangle$Average Normalized Gain

NNumber of Students in Sample

rCorrelation Coefficient

Chapter 1

Problem Statement

On February 7th, 2012 the President's Council of Advisors on Science and Technology (PCAST) delivered a report (The President's Council of Advisors on Science and Technology, 2012). It described in detail the failing state of our country's training of science, technology, engineering and mathematics (STEM) professionals as well as possible solutions to this growing problem. The report states that our country needs one million more STEM professionals than will be produced at the current rate over the next decade. Currently, fewer than 40% of students who enter STEM fields as undergraduates complete their degree. Most of these students are lost during the first two years of their undergraduate degree due to insufficient mathematical understanding and uninspiring introductory courses (The President's Council of Advisors on Science and Technology, 2012). While many solutions to this problem are proposed, the obvious and most cost effective response would be to increase our retention rates. If retention rates were to climb from 40% to 50%, it would generate three-fourths of the one million required STEM professionals (The President's Council of Advisors on Science and Technology, 2012). Three major retention-based recommendations are posed in the report, the second being of great importance to this work: "Advocate and provide support for replacing

standard laboratory courses with discovery-based research courses” (The President’s Council of Advisors on Science and Technology, 2012, p. ii). Discovery-based laboratories are defined as laboratories where multiple routes can be taken towards the discovery of a scientific relationship or concept (Bodner, Hunter, & Lamba, 1998).

Expert-like thinking, or thinking that resembles that of an expert, has also been shown to increase retention in STEM majors (Wieman , 2012) and is a better predictor of a student’s success in a four-year physics program than a student’s final grade in their introductory course. Changing student thinking to more expert-like views has the potential to increase retention and learning in undergraduate physics. Additionally, learning in physics is often tied to expert-like thinking (Wieman & Perkins, 2005). Novice physics students tend to believe that physics consists of isolated pieces of information that are handed down by authority and meant to be memorized (Wieman, 2012). Physics experts, as well as physics students with expert-like thinking, understand that the physics content contains a coherent structure of concepts which were established by experiment and attempt to describe nature. Expert-like thinking in physics can be described through two important and distinct categories (Reddish & Hammer, 2009). Conceptual understanding of introductory physics content is an obvious category, since expert-like physicists have a complete conceptual understanding of introductory physics. Simultaneously, the attitudes of an expert-like thinker are separate from their conceptual understanding of physics (Zwickl, Finkelstein, & Lewandoski, 2013). These two important types of learning in introductory physics, conceptual understanding and attitudes, can be used and adapted to encompass laboratory physics as well.

Conceptual learning in a physics laboratory includes the traditional content areas, measured by common concept tests such as the Force Concept Inventory (FCI). It must also include ideas about experimentation, such as data processing, uncertainty, and experiment design (Taylor, 1997). Expert-like laboratory physicists have a complete conceptual understanding of data interpretation and processing that is often absent in novice physics experimentalists. Measurement of this component of conceptual understanding currently has no common test that is widely used.

Additionally, expert-like attitudes about a laboratory and experimentation are distinct from the expert-like attitudes of students in lecture hall. This difference has caused the Physics Education Research Group (PERG) that initially developed the Colorado Learning Attitudes about Science Survey (CLASS) to develop a new attitude test centered on laboratory physics: The Colorado Learning Attitudes about Science Survey for Experimental Physics (E-CLASS) (Zwickl, Finkelstein, & Lewandoski, 2013).

Currently, many laboratory courses implemented at the college level are considered “cookbook” laboratories. In cookbook laboratories, students are expected follow set instructions to produce pre-determined results. Most students in STEM fields must wait until the last years of their degree before they can experience the excitement of engaging in scientific research (The President’s Council of Advisors on Science and Technology, 2012). According to the PCAST report, many of these potential students have already left their program due to the retention problems in the introductory courses. Providing laboratory experiences throughout those introductory courses with the goal emulating research and scientific experimentation is of great importance to the

identification (Hunter, Laursen, & Seymour, 2007) and retention (Kinkel & Henke, 2006) of potential STEM professionals. Implementing these changes also tends to increase students' grades (Barlow & Villarejo, 2004), shorten the time for students to obtain an undergraduate degree (Kinkel & Henke, 2006), and increase students' interest in graduate education (Lopatto, 2007). It has yet to be determined if these laboratories increase expert-like thinking of STEM students, which is also directly tied into their retention. By tracking changes in students' attitudes and conceptual understanding regarding laboratory physics I can begin to determine if there is a difference in expert-like thinking between cookbook laboratories and discovery-based laboratories.

1.1 Purpose Statement

Using ideas proposed by physics education researchers at The University of Maryland I have revised the physics laboratories at the University of Toledo from traditional laboratories to discovery-based laboratories. Through this dissertation I describe the implementation of these discovery-based laboratories. I have investigated the changes in student conceptual knowledge, attitudes, and understanding of uncertainty that occur when executing these laboratories and compared them to learning that occurs in traditional laboratories. The changes in these categories give insight into the change in expert-like thinking for a typical student in discovery-based or traditional laboratories.

Discovery-based laboratories, including the specific laboratories used by The University of Maryland, have not been investigated using these evaluations. These evaluations will provide important insight into the effectiveness of discovery-based laboratories as a tool for learning physics, changing the amount of expert-like thinking in

students, and possibly retaining students as STEM majors. The purpose of this study is to investigate if implementing discovery-based laboratories in place of traditional laboratories can improve students' expert-like thinking with regards to physics. Also, I have investigated which aspect of the changes in expert-like thinking is the strongest and if there are any correlations between the categories. Additionally, I have measured conceptual understanding and students' attitudes regarding physics laboratories to gauge these changes in expert-like thinking. This study seeks to describe the outcomes of implementing discovery-based laboratories as well as the potential importance of modifying department laboratory curricula to meet the PCAST recommendations.

1.2 Research Questions

1. How do students' conceptual knowledge about physics differ between traditional laboratories and discovery-based laboratories?
2. How do students' attitudes regarding physics laboratory differ between traditional and discovery-based laboratories?
3. How do students' understanding of uncertainty differ between traditional and discovery-based laboratories?
4. Are there correlations between the changes in understanding of uncertainty and conceptual knowledge or attitudes regarding physics laboratories?

This study took place over the fall semester of 2012, in a calculus-based introductory physics course titled *Physics 2130: Physics for Scientists and Engineers* at the University of Toledo. Nearly 300 students take this class each semester, attending

separate lectures, recitations, and laboratory sections. At the beginning of the semester, students self-select one of over two dozen laboratory sections. I have chosen three of these laboratory sections to serve as discovery-based laboratories, where discovery-based laboratory techniques were implemented. For comparative purposes, I have picked four other laboratory sections to serve as traditional laboratories. The extent these methods improve students' expert-like thinking was measured using pre-post assessments regarding conceptual understanding and attitudes about introductory physics laboratories.

In this dissertation, I will review different types of introductory laboratories, what it means to understand laboratory physics, and different techniques used to measure students' understanding of laboratory physics. I will compare the results of these changes between the traditional laboratories and discovery-based laboratories and discuss the possible implications of using these laboratories in place of traditional laboratories during a student's introductory physics experience.

Chapter 2

Literature Review

Through this literature review, I describe the purpose of including a laboratory in an introductory physics curriculum and the types of learning expected of students through a laboratory. These kinds of learning can be achieved through multiple laboratory techniques, including traditionally run laboratories and discovery-based laboratories. Some laboratory techniques differ in the amount of student learning. I will detail these different techniques and describe an example laboratory that uses each technique. These laboratory types will be the focus of this dissertation.

2.1 Learning Physics

The main goal of physics instruction is to guide students to more expert-like understanding and beliefs about physics (Reddish & Hammer, 2009). The two main components of this expert-like interpretation of physics are expert-like conceptual understanding and expert-like attitudes about physics. Those two areas represent the types of learning expected of students in introductory physics courses. This conceptual and attitudinal learning should also extend to components related to experimentation (American Association of Physics Teachers, 1998).

2.1.1 Conceptual Learning

Conceptual understanding in introductory physics is considered to be learning the basic content as well as the ability to use that content to predict and explain physics phenomena (Reddish & Hammer, 2009; Wieman & Perkins, 2005). Through a first semester introductory physics course, students must learn many of the basic conceptual components of force and motion topics. These topics are considered important in both the laboratory and in lecture components (American Association of Physics Teachers, 1998).

Physicists tend to have a coherent, well organized conceptual framework (Reddish E. , 1994). They tend to see physics concepts as a few main ideas that can be used to develop the individual conceptual areas of introductory physics. Novice physics students tend to see introductory physics as isolated and disconnected facts (Reddish E. , 1994). These facts are typically disorganized and incoherent within the students' conceptual framework.

2.1.2 Attitudes

The other important component of physics learning is students' attitudes about physics. In general, attitudes can come as positive or negative feelings about multiple aspects of a subject. Improved attitudes regarding physics have been correlated with increased student retention through a four-year physics degree and better grades in first year physics classes (Perkins, Granty, Adams, Finklestein, & Wieman, 2005) and are a key part of expert-like thinking in introductory physics (Reddish & Hammer, 2009).

Attitude surveys differ in the ways that they break attitudes down into categories. For example, one of the most pervasive physics attitude surveys uses the following

categories to describe student attitudes about physics: *Personal Interest, Real World Connections, Problem Solving, Sense Making/ Effort, and Conceptual Understanding* (Adams, et al., 2006). Questions from these surveys typically capture the attitudes of students in physics lecture.

As result of the 2012 PCAST report, (The President's Council of Advisors on Science and Technology, 2012) a distinction has been made between attitudes learned through laboratory physics and the physics learned through lecture (Zwickl, Finkelstein, & Lewandoski, 2013). Categories for attitudes regarding experimental physics include: *Affect, Argumentation, Confidence Experimental Design, Math-Physics-Data Connection, Modeling the Measurement System, Physics Community Purpose of Labs, Statistical Uncertainty, Systematic Error, and Troubleshooting* (Zwickl, Finkelstein, & Lewandoski, 2013). Attitudinal surveys are described in more detail in chapter 3.2.

2.1.3 Connection between attitudes and conceptual learning

A correlation exists between the concepts learned through lecture and the attitudes of students. Two independent studies have concluded that an improved attitude about physics has a connection to increased conceptual understanding of physics (Perkins, Adams, Pollock, Finkelstein, & Wieman, 2004; Milner-Bolotin, Antimirova, Noack, & Petrov, 2011).

Researchers at the University of Colorado have investigated the relationship between attitudes and conceptual learning through their introductory physics class (Perkins, Adams, Pollock, Finkelstein, & Wieman, 2004). In their study they gave over 200 of their introductory physics students both the Colorado Learning Attitudes about Science Survey (CLASS) and the force and motion concept evaluation (FMCE) at the

beginning and end of the semester. Both of these surveys are described in detail in section 3.2 and 3.1 respectively. They discovered a correlation of $r = 0.26$ between CLASS expert-like thinking and FMCE scores at the end of the semester.

Similarly, the University of Toronto has conducted a study comparing student attitudes to their conceptual gains in an introductory physics course (Milner-Bolotin, Antimirova, Noack, & Petrov, 2011). Participants took the force concept inventory (FCI) as well as the CLASS at the beginning and end of a semester. Over 100 introductory students in the course completed all portions of the study. Their results yielded a similar correlation coefficient of $r = 0.258$, connecting attitudes and conceptual learning once again.

2.1.4 Procedural Learning

Learning about the experimental process is a typical part of the first semester physics laboratory (American Association of Physics Teachers, 1998). This learning pertains to data processing, uncertainty, and experiment design. While these concepts are often a vital part of any laboratory or experiment, they are often a neglected part of introductory laboratories (Taylor, 1997).

2.2 Importance of Laboratories in Introductory Physics

The purpose of experimentation as a part of an introductory physics course has been discussed and debated for some time by physics instructors. In 1998, The American Association of Physics Teachers (AAPT) brought together many of the committees that have insight into laboratories at the college level, and developed and negotiated the goals and purpose of laboratories as part of the introductory physics curriculum. Their findings

have been broken into five categories: *The art of experimentation, experimental and analytical skills, conceptual learning, understanding the basis of knowledge in physics, and developing collaborative learning skills* (American Association of Physics Teachers, 1998).

The art of experimentation refers to students obtaining experiences with the experimental process. Students should not only get to execute an experiment, but be able to develop and test their own ideas and designs for their experiment. The AAPT suggests that the moments when students achieve intellectual discoveries on their own can be some of the most scientifically engaging moments. By the end of a laboratory class students should understand that experimentation is as important as physics theories when it comes to introductory physics.

The *experimental and analytical skills* category acknowledges that students must learn the basic skills needed for data analysis and interpretation in their introductory physics laboratory. Students must have experience with the tools necessary to collect data and the limitation of those devices. This experience requires students to have the ability to understand uncertainty and differentiate it from data recording mistakes.

Conceptual learning describes the mastery of basic physics concepts. Learning concepts has long been considered a goal of laboratories; however, the AAPT cautions that verification laboratories lead to difficulties in learning basic concepts.

Students should not just be able to do the required experimentation, but also be able to understand the role of direct observations in physics. This ability is described by the *understanding the basis of knowledge in physics* category. By the end of a laboratory course, students should understand that the many equations and laws of physics do not

come from textbooks, but from experimental evidence gathered through years of research. Most students do not have sufficient experience with quantifying everyday phenomena to understand the relationship between the construction of physics theories and observation. It is the goal of laboratory experiences to develop these connections.

Developing collaborative learning skills is as much a lifelong goal as well as a physics laboratory goal. Collaborative learning is a skill that most people must have through their professional lives and has therefore become an emphasis of physics laboratories.

These five goals elucidate the purpose of laboratory in the physics classroom and the reasons why it is part of the introductory physics curriculum. These goals begin to reveal not just the purpose of laboratories, but what it means for students to learn as they attend their laboratory.

2.3 Traditional Laboratories

Traditional laboratories is the umbrella term used to describe what many refer to as *verification laboratories*, or what other some describe as *cookbook laboratories*.

There is no one specific laboratory type that is considered the traditional laboratory, rather many different laboratories that fall into this genre. They often involve repeating classical experiments to reproduce known results (The President's Council of Advisors on Science and Technology, 2012). In a traditional laboratory, students spend most of their time on the logistics of acquiring and processing data and little time making sense of what is happening (Reddish & Hammer, 2009). In these laboratories, if a student's experimental answer is different than their computed answer (achieved through physics

problem solving) then that student must find the percentage difference from the correct answer and explain why there is a discrepancy in a cursory manor. Students spend most of their time following the specific protocols given in the laboratory manual and little to no time sense making (Reddish & Hammer, 2009).

It is important to note that the traditional laboratories only achieve three out of the five of the AAPT's goals for introductory physics laboratories (American Association of Physics Teachers, 1998). The first two goals, *the art of experimentation* and *experimental and analytical skills*, are not a part of the traditional laboratory design elements. *The art of experimentation* expects students to have the opportunity to design their own experiment, or at least add their own ideas to the experimental process. The rigidness of traditional laboratories makes it impossible for students to do this during their experimentation (Zwickl, Finkelstein, & Lewandoski, 2013). Also, *experimental and analytical skills* are often missed by traditional laboratories due to the fact that the data processing is directed by the laboratory manual. The only experience students have with uncertainty is the laboratory manual telling them to collect multiple data points and averaging with little regard to why (Zwickl, Finkelstein, & Lewandoski, 2013). The way the laboratory manual directs the students to do error analysis is to calculate the percent different between their results and the correct answer. Traditional laboratories fail to meet the AAPT's goals, and a new approach is needed to obtain these goals from introductory physics laboratories.

2.3.1 Realtime Physics Laboratories

Currently the University of Toledo's Physics Department and many other physics departments around the country run varying versions of the *Realtime Physics Labs*

created by Thornton and Sokoloff (Sokoloff & Thornton, 2007). These laboratories were created in the early nineties to give departments a means of conducting physics experiments as part of their curriculum. Departments were often forgoing a laboratory section due to the high monetary cost of stocking a physics laboratory. Thornton and Sokoloff were able to unite the computer and the newly developing technologies of the time (force probes, motion sensors, etc.) to create physics modules that would be easy for a department to afford and execute.

In these laboratories, students follow a set of instructions detailed by a laboratory manual to achieve a predetermined set of results. Students make predictions, run the experiments, and do the necessary data acquisition to complete the laboratory. In their study, Thornton and Sokoloff analyzed the gains of students on a standard physics concept test called the Force and Motion Concept Evaluation (FMCE), which is described in more detail in chapter 3.2. After testing University of Oregon students in 1989 and 1990, they discovered students began the semester with an average pre-test score of 15%. Students who participated in both the lecture and the laboratory earned average post-test score of 80%. Students who only participated in the lecture and did not take a laboratory section achieved an average score post-test of 20% percent (Sokoloff & Thornton, 2007).

These laboratories still expect students to follow a predetermined set of tasks to verify known results as detailed by their laboratory manual. Therefore, these laboratories fit into the category of the traditional laboratory, and will be described as such throughout the remainder of this dissertation.

2.4 Discovery-Based Laboratories

In discovery-based laboratories multiple routes can be taken towards the discovery of a scientific relationship or concept (Bodner, Hunter, & Lamba, 1998). Research opportunities that are discovery-based have been shown to improve student attitudes regarding physics (Russell, Hancock, & McClough, 2007) and increase retention in undergraduate programs (Nagda, Gregerman, Jonides, Von Hippel, & Lerner, 1998).

Russell et al. (2007) conducted a web-based survey between 2003 and 2005 with over 15,000 respondents from all major STEM fields. Undergraduate students, graduate students, post-doctorate students and faculty all responded to surveys about their undergraduate research experience as well as why they had chosen and stuck with their STEM career. Their data suggested that undergraduate research early in a student's undergraduate degree will increase a student's interest in their STEM career. Students who engaged in early undergraduate research reported greater confidence in their research skills and greater enjoyment of their field.

Nagda et al. (1998) implemented a program at The University of Michigan that established research relationships between faculty and undergraduate students in their first or second year of school. Over 1000 undergraduate students in numerous departments were chosen to be paired with faculty. Implementing a research relationship with faculty improved the retention for University of Michigan students. African American attrition decreased from 18.3% to 10.1% and Caucasian student attrition decreased from 6.1% to 3.1% due to the early undergraduate research.

Due to these benefits of early undergraduate research, the President's Council of Advisors on Science and Technology (2012) recommends the use of discovery-based laboratories over traditional laboratories in the first two years of the undergraduate curriculum.

2.5 Scientific Community Laboratory

The Scientific Community Laboratory was designed by Dr. Rebecca Lippman of the University of Maryland to establish a frame for students that has them completing the actions of an experimental physicist (Lippmann, 2003). By executing these actions, she suggests students will change their ideas about knowing, called epistemologies. Through the actions of designing, analyzing, and defending experiments, students move away from considering knowledge as certain and toward seeing knowledge as fabricated through experimentation and conversation (Lippmann, 2003). Since students may take multiple paths in the design and defense of their experiments toward the discovery of a scientific concept, this laboratory type is considered a discovery-based laboratory.

2.5.1 Frames

A frame is a state of mind related to the larger context and helps determine what actions the student will take (Lippmann, 2003). People negotiate through different frames constantly. As both a parent and a professional, one will learn very quickly to change his or her state of mind to achieve acceptable actions in both contexts. Students sitting through a physics laboratory consider different activities appropriate as well (Lippmann, 2003). A student who expects to learn about the process of doing science will have a different expectation of a laboratory setting than a person expecting to learn

specific concepts. These different expectations of the laboratory will result in the actions of the student being different. In the first case, a student might see an error as part of the experiment and account for it, whereas in the second case a student may see the inconsistent result as human error and interpret the experiment as a failure. Laboratories should establish a frame consistent with the mental state and actions that the students are expected to take.

A frame consistent with a traditional laboratory expects students to be correct or consistent with theory (Lippmann, 2003). Any amount of error in the laboratory is related to how far off you were from the “correct” answer and is usually diagnosed as human error or some generic friction. Consistent with this mindset, laboratories are generally evaluated by teaching assistants based on the correctness of student responses.

Designers of the Scientific Community Laboratories expect students to put themselves in the frame of an experimental physicist. They must design experiments, take meaningful data, and analyze that data to make conclusions about the concepts they are learning. Students must also be able to discuss and defend their findings through presentations between peers and laboratory reports that act similarly to the way peer review is done in a professional journal. Through this process, students are engaging in actions consistent with those of an experimental physicist to complete the laboratory.

2.5.2 Epistemologies

Epistemologies regard ideas about knowledge and knowing. There are multiple different kinds of epistemologies, including essentialism, perennialism, progressivism, empiricism, idealism, rationalism, and constructivism. The two types that relate to laboratory science are: empiricism and constructivism.

Empiricism is the educational philosophy that experience dictates the formation of ideas and knowledge. An empiricist typically expects that scientific knowledge emerges infallibly from objective data. These ideas are consistent with the expectations of a traditional laboratory (Lippmann, 2003). Students in these laboratories confirm previously known results or theories. They are expected to achieve the correct answer to a problem using certain data and learn the content of the day after they have experienced it.

A constructivist considers learning as the conjoining of information with existing knowledge (Lippmann, 2003). Students with constructivist epistemologies assume that knowledge is individually constructed and socially co-constructed by learners based on their interactions. The expectations of a constructivist are aligned with the actions and collaborations of the Scientific Community Laboratories. Students in these laboratories must bring their existing knowledge to the construction of experiments that are discussed and debated until everyone has correctly reconciled their learning with their previous knowledge of the subject.

A student's epistemology affects the methods a student uses to learn physics (Hofer, 2001). For example, in physics, students who maintain the empiricist belief that all scientific knowledge emerges from infallible, objective data were more likely to learn by memorization. In comparison, students who hold the constructivist belief (consistent with experimental physicists) that scientific knowledge is tentative and continuously being invented were less likely to learn by memorization (Tsai, 1998). These misconceptions about epistemology can be corrected by looking at ideas of uncertainty, statistical error, and systematic error. These topics delve into where knowledge comes

from and how reliable it is, so it is likely to affect student epistemologies (Lippmann, 2003).

Correct conceptions about epistemology can go a long way to assisting in student learning. During interviews, thirty introductory students at Ohio State University reported on what they learned in physics and how they learned it (May, 2002). This study reports that students' ideas about what physics was and how to learn it accounted for over 70% of students' gains on the Force Concept Inventory.

Epistemologies do not necessarily have to be uniform or consistent within a student. Epistemologies can change between domains (May, 2002), meaning that a student may have a completely different epistemology inside a physics class than they do inside a chemistry or sociology class.

2.5.3 Design of Scientific Community Laboratories

By being placed in a frame where they must produce, analyze, and evaluate scientific evidence, students will be deterred away from empiricist epistemologies and towards constructivist epistemologies. They must stop thinking in terms of knowledge being certain and move toward seeing knowledge as fabricated through experimentation and conversation (Lippmann, 2003). They must link theory with practice; learn experimental skills; get to know the methods of scientific thinking; and foster motivation, personal development, and social competency (Lippmann, 2003). The goals are directly aligned with every aspect of the AAPT goals for introductory physics laboratories (American Association of Physics Teachers, 1998). When designing the University of Toledo version of the Scientific Community Laboratories, I have deferred to these design elements and goals to create laboratories that reflect their main ideas.

2.5.4 Research Results of Scientific Community Labs

Studies done regarding the Scientific Community Laboratories (SCL) were mainly accomplished by the creator of the laboratories, Dr. Lippmann. To study her laboratories, she took video recordings of the class and transcribed them to get a sense of student conversations throughout the sessions (Lippmann, 2003). These conversations were coded into three categories: off topic, logistics, and sense making. *Off topic* represented students discussing things that were not pertinent to the laboratory. *Logistics* referred to students' conversations about things functionally necessary to complete the laboratory. Examples of logistics included data collection, experimental setup, and number crunching. *Sense making* was a broad category that encompassed any moment that a student was discussing ideas, debating, and making sense of numbers. This category tried to capture moments where students had their brains turned on and were actively thinking. It was thought that students who spent more time in the sense making category were doing more thinking, and therefore were engaged in more learning.

The time spent in each of the three categories for the SCL and traditional laboratories showed that students in SCL laboratories engaged in more sense making than the traditional laboratories and that they transitioned into the sense making category more often. Simultaneously, students in the traditional laboratories spent more time in the logistics category, mostly going through the motions of the laboratory. Also, transitions into sense making were rare in these students, showing that these laboratories tended to discourage critical thinking as compared to the SCL laboratories. For example, metacognitive statements such as "I don't understand" would generally lead to students asking the teaching assistant (TA) for help in the traditional laboratories. Students in this

predicament in the SCL were more likely to try to think through the situation and figure things out for themselves, making a transition into the sense-making category.

The Scientific Community Laboratory has not been well studied past these results. In fact, The University of Maryland does not even use these laboratories anymore! The main driving force behind these laboratories, Dr. Lippmann, is no longer with the department. In her absence, the Scientific Community Laboratories have fallen by the wayside at The University of Maryland. To this day, none of the standard measures for introductory physics have been completed on the Scientific Community Laboratories, leaving room for much research and evaluation of the laboratories.

Chapter 3

Methods Review

3.1 Physics Concept Tests

Physics educators have relied on concept assessments to track conceptual learning through physics courses for almost thirty years. They are often used as a metric to diagnose changes in students' conceptual knowledge through a semester of physics instruction. The tests developed include the Mechanics Diagnostic Test (MDT), the Force Concept Inventory (FCI), the Mechanics Baseline Test (MBT), and the Force and Motion Concept Evaluation (FMCE).

3.1.1 Mechanics Diagnostic Test

The Mechanics Diagnostic Tests (MDT) was the first of these tests and was developed to probe understanding of many of the ideas in a first semester physics course. It solely covers students' understanding of Newtonian Mechanics (Halloun & Hestenes, 1985) through both conceptual questions and more mathematically-based questions. It was created to find the connection between pre-instructional mathematical reasoning skills and the change in student conceptual knowledge.

The test was developed as an open-ended test, where students wrote in the answers to their questions. From there, common wrong answers were put as distractors

into a multiple choice version of the test. For further validation, the Kuder-Richardson test was performed on both the written version and multiple choice versions of the test and achieved a high reliability coefficient of 0.86 and 0.89, respectively, indicating that student answers were mostly internally consistent and the test is homogeneous.

Pre-test scores for each category of student population showed consistent results. The authors concluded that these tests assess different components of students' knowledge, meaning that both mathematical knowledge and conceptual knowledge are independent of one another. However, both components together can be used as a predictor of a student's performance in their introductory physics course.

An analysis of pre-test and post-test results revealed student conceptual gains of only 10% to 20% through a semester's course in physics (Halloun & Hestenes, 1985). For the first time, these results showed the failure of conventional instruction to convey concepts in a way that would fundamentally alter student preconceptions. For this reason, tests like this one have been used to track students' conceptual knowledge and to diagnose student misconceptions over the course of a semester.

3.1.2 Force Concept Inventory

The Force Concept Inventory (FCI) was developed as an improvement upon the Mechanics Baseline Test (Hestenes, Wells, & Swackhamer, 1992). The FCI was constructed using the same method as the MDT, including validation. The final inventory included more than half of the conceptual questions from the MDT. The mathematical portion of the test was removed and sections covering additional conceptual topics were added. The full test covers topics from a first semester physics

course and has been divided by the authors into the following categories: *kinematics*, *Newton's laws*, *the superposition principle*, and *various kinds of forces*.

The test also probes common physics misconceptions. A misconception is an incorrect view established due to faulty understanding of a topic. Novice views about physics often come from an incomplete understanding of the surrounding world. For example, a common misconception about Newton's Laws is that a constant force causes objects to move at a constant velocity. Physics instruction intends to correct many of these misconceptions, so it is useful to analyze these misconceptions using the FCI and other similar tests. The authors have divided the inventory into six misconception categories: *kinematics*, *impetus*, *active force*, *action/reaction pairs*, *concatenation of influences*, and *other influences of motion*. The authors suggest that the overall score in these categories may provide a more useful indication of student misconceptions than answers to individual questions, as individual questions may have been answered correctly by chance. They also discuss the common sense answers for many of these topics that lead to many of the misconceptions rampant throughout physics (Hestenes, Wells, & Swackhamer, 1992).

The authors encourage instructors to use this test to diagnose student misconceptions; however, they caution against looking at difficulties on individual questions or using these questions for instruction purposes. Instead, overall scores in each of the six misconception categories should be used as a general indication of student misconceptions.

The FCI can be used reliably to compare the results of instruction between differing teaching methods. The authors consider a score of 60% or greater to be the

entry threshold into the understanding of Newtonian physics. Students at this level have barely begun to use Newtonian concepts coherently in their reasoning. Any scores higher than 85% are regarded by the authors as *mastery threshold*. The authors consider students with this score to be confirmed Newtonian thinkers. This test is easily the most widely used in the testing of introductory physics classes.

3.1.3 Force and Motion Concept Evaluation

The Force and Motion Concept Evaluation (FMCE) holds a close second to the FCI for the most used introductory physics concept test (Thornton & Sokoloff, 1998). The FMCE covers similar topics to the FCI, however it asks more questions and gives more multiple choice answers for students to choose from. The test is also arranged into different problem types and asks students multiple questions of each type to probe their understanding on a continuum from non-Newtonian to Newtonian thinking. Another important difference between the FMCE and the FCI is that the FCI usually has no students scoring lower than 20%. The FMCE asks different enough questions with diverse enough answers such that there is a body of students who score between 0% and 20%. This variation can give a slightly better resolution to the differences between each student's conceptual understanding of introductory physics and can be valuable for many classes with a more diverse population of students. Students enrolled in The University of Toledo's calculus-based introductory physics course traditionally begin with FCI scores greater than 40%, so this effect doesn't appear, and either test can be used effectively. Between the two, I have chosen the FCI as the conceptual survey for this study, as it is the test I have seen most typically used and the survey with which I am most familiar.

Hake developed his own method for analyzing concept test results (Hake, 1998). In his paper, he describes using the average normalized gain to compare FCI results. This method provides comparisons that are independent of the pre-test score. Average normalized gain is calculated by dividing the average FCI gain by the maximum possible gain. Using this method, Hake analyzed the FCI scores of over 6000 students in over sixty classes and discovered notable differences between traditional, lecture-based classes and classes that used interactive engagement methods. Methods that allow students to interact with physics concepts such that they must actively engage in their own learning and construct their own understanding of physics are considered interactive engagement methods. Traditional classes were typically only able to produce an average normalized gain of 0.23. Interactive engagement methods scored anywhere between 0.34 and 0.69 and showed no overlap with the traditional classes. This result led Hake to define three categories of possible gains: gains greater than 0.7 are considered high, gains between 0.3 and 0.7 are considered medium and gains less than 0.3 are considered low. Using these definitions, traditional lecture falls into the low gain category while interactive engagement lectures generally fall into the medium gain category.

3.2 Attitude Surveys

In the past fifteen years there has been an emphasis on attitudes of students with regard to learning physics. Surveys like the Views About Sciences Survey (VASS), Maryland Physics Expectations Survey (MPEX), and Colorado Learning Attitudes about Science Survey (CLASS) have been used through the years to measure students attitudes.

3.2.1 Views about Science Survey

The VASS was created to study students' beliefs about the nature of science (Halloun & Hestenes, 1996). It seeks to discover student views about how they know and learn physics. The survey gives two contrasting choices and asks which one the student believes is most true. For example, a statement from VASS reads: learning physics requires a serious effort, or a special talent. Students can indicate they believe in one view or a combination of the two. There are six dimensions to this survey: structure, methodology, validity, learnability, reflective thinking, and personal relevance (Halloun & Hestenes, 1998). The survey was administered to college and high school physics teachers to calibrate an expert view of physics. Views opposing the expert-like position were characterized as "folk views." One of the weaknesses of this test is that students are not necessarily coherent or consistent with their epistemologies. In fact, other research seems to indicate that epistemologies can be topic-specific (May, 2002) or even situation-specific (Lippmann, 2003).

3.2.2 Maryland Physics Expectations Survey

The University of Maryland created their own survey base on conversations with physics faculty and extensive literature review: the Maryland Physics Expectations Survey (MPEX). This survey also examines students' attitudes about learning physics (Reddish, Saul, & Steinberg, 1998). The survey is thirty-four questions on a five-point Likert scale where students are asked to report their views about learning physics. The six dimensions that the MPEX use are: *independence*, *coherence*, *concepts*, *reality*, *math link*, and *effort*. Students' responses are judged based on whether they agree with experts or disagree with experts. The author indicates that interviews are necessary to truly

classify the individual attitudes of students, and that these tests are meant to give results for large numbers of students.

3.2.3 Colorado Learning Attitudes about Science Survey

The Colorado Learning Attitudes about Science Survey (CLASS) builds upon the MPEX survey (Adams, et al., 2006). This survey is meant to gauge a wide variety of topics relevant to introductory physics students as well as issues relevant to education research. To check each question on this survey, student interviews were conducted. These interviews were used to indicate whether students consistently interpreted the questions the same way that experts interpreted the questions. This led to questions that were relevant and meaningful to both students and researchers.

In the previous surveys, students' responses were not always internally consistent, indicating that students' ideas about learning are not always coherent (Adams, et al., 2006). In previous surveys that asked multiple similar questions to test for consistency, a student may have had divergent answers to those questions. One of the successes of the CLASS survey is that the categories they created seem to show internal consistency. Students answer similarly within a category, meaning the statistics are more robust than previous surveys. Their category designations are: *personal interest*, *real world connections*, *conceptual connections*, *sense making/effort*, *problem solving*, and *applied conceptual understanding*. To check for consistency, students were asked to submit their answer alongside the answer they believe a physicist would give. This technique is used in many surveys to indicate reliability in the survey as well as dissonance between what students are taught and what they actually believe. In reformed physics classes, students

tend to have different answers for physicists and themselves less often than in traditional introductory physics classes (Reddish & Hammer, 2009).

3.2.4 CLASS for Experimental Physics

The CLASS survey has been modified to be usable in physics, biology, and chemistry classes covering many of the attitudes specific to these topics. The E-CLASS survey was very recently developed to fill the niche of attitude surveys regarding experimental physics (Zwickl, Finkelstein, & Lewandoski, 2013). It has been developed and validated similarly to the CLASS survey, however, instead of individual categories, each question is meant to stand on its own (Zwickl, Hirokawa, Finkelstein, & Lewandowski, 2013). The survey asks thirty-two questions on a five-point Likert scale, and can be used as a pre-test and post-test to gauge changes in student attitudes about experimental physics. It asks students to indicate their view as well as what they believe the view of an expert physicist would hold. Student responses are then designated as expert-like (agreeing with experts) or not expert-like. Fractions of responses in the expert-like category can indicate general changes in the attitudes of the students.

3.3 Measuring Student Understanding of Uncertainty

Surprisingly few evaluations of students' understanding of uncertainty have been developed through the years. Existing research focuses on identifying students' difficulties with interpreting single and multiple measurements.

In 1996 more than 1000 students in the United Kingdom between the ages of eleven and fifteen were surveyed about data analysis (Lubben, 1996). A hierarchy of levels of student understanding of uncertainty was compiled. Each level is specified by

three ideas: a view of the process of measuring, a way to evaluate the result, and a method for dealing with anomalous data. The goal of instruction is to move students to higher levels of the chart; hopefully getting students to the highest level, level H. While the topics of the amount of data, statistical error, and outliers are covered in the hierarchy, a large topic missing is systematic error. When the data students collected was correctly taken and processed correctly there is potential for the results to still be incorrect no matter what students do. This is still acceptable in experimental physics and is called systematic error. If students can account for the discrepancy and add it into their results, it is completely acceptable.

A physics measurement questionnaire was created to build upon this work (Buffler, Allie, Lubben, & Campbell, 2001). This questionnaire involved a single experimental context, a ball rolling down a ramp and then flying off a horizontal table onto the floor. Students were asked multiple choice questions about which reasoning they agreed with. Students' answers were classified as coming from one of two paradigms. If they indicated that measurement leads to a single value they were described as reasoning within the point paradigm. If they indicated that multiple measurements within a range of information were needed to establish a result, they were described as reasoning from the set paradigm. Students reasoning from the point paradigm were likely to take only one measurement, or if they took multiple measurements, it was to find a repeating value to report. Conversely, students reasoning from the set paradigm were likely to take multiple measurements and consider the resulting range of values to define a confidence interval surrounding the average of the points.

After analyzing 70 first-year university students' responses, Buffler et al. (2001) saw marked decreases in students reasoning from the point paradigm. The students transitioned from 57% to 13% point paradigm answers after a semester of physics instruction. However, when asked to explain their reasoning, they discovered that many of the students were able to use the mathematical tools of the set paradigm, but not able to reason within the set paradigm. This led the researchers to devise another criterion between the set and point paradigm, described as rote and ad hoc set actions with point paradigm reasoning. Students in this category were able to memorize certain methods of data analysis such as averages and standard deviation, but were unable to back up those actions with set paradigm reasoning. After coding using this new scheme, they discovered that of the 57% originally coded as set reasoning, only 23% of the students were using set reasoning to answer the questions. This meant that 34% of students were using set paradigm methods while truly being invested in the point paradigm.

Other research has centered on observing students' understanding of uncertainty. One study looked at first-year university students in a physics course in France (Sere, Journeaux, & Larcher, 1993). Both laboratory and lecture maintained a goal to teach uncertainty, yet it seemed that even after instruction students didn't have an underlying understanding of uncertainty analysis. In their experience and through their interviews they discovered the following about students:

1. Students would not run multiple tests unless they doubted their first measurement.
2. Students understood that more measurements were better, but did not understand why.

3. Students preferred the first measurement over the repeated values.
4. Students would only describe the precision of the measuring instrument when required to do so.
5. Students considered a large standard deviation bad and failed to take systematic errors into account.

From this data, Sere concluded that many students only memorize the mathematical tools instead of the underlying measurement concepts. This result is similar to the Buffler 2001 results where students could use the mathematical tools yet were invested in the point paradigm. It will also be important later when evaluating interviews since many of the students in the interviews can do the mathematical sections of the interview yet fail to describe why.

In a follow-up study, Coelho and Sere (1998) interviewed twenty-one French high school students. The researchers observed a laboratory in progress and the interviewers were able to ask questions such as “why did the puck’s velocity change?” or “Why have different results been obtained?” Nine out of eleven groups described a belief in a true value for their measurements. They also tended to reject variability in their data. The students who believed in a true perfect value would often try to search for it by conducting multiple measurements to try to “get it right.” Despite these misconceptions, the students were able to perfectly execute the math needed to process the data. The researcher mentions that this discrepancy between understanding and execution is due to students being able to memorize and apply the mathematical methods needed without a correct or complete understanding of uncertainty. This result appears to be a common

occurrence in courses that emphasize logistics and do not emphasize making sense of the process of doing science (Lippmann, 2003).

Through my own anecdotal observations, I have noticed that students are naturally drawn to a point paradigm through the physics lecture. In lecture, students are asked to answer problems where all of the initial information is given and concrete. The answers they calculate will be either right or wrong and there will only ever be one possible answer. This result is in dissonance with how research is accomplished in science. Researchers would be dismissed if they published a paper with one data point as the entirety of evidence they submit. Most of the traditional laboratories in The University of Toledo ask students to collect multiple data points. Unfortunately, very little time is spent in laboratory or in the laboratory manual instructing students as to why they need to collect multiple data points or what to do with their data outside of taking the average. This process, in conjunction with the “true value” concept from lecture, may push students towards thinking in terms of the point paradigm. While they may be going through the motions of the set paradigm, they may be completely invested in the point paradigm through their experience in lecture. This topic is one of the many topics I will be investigating through my uncertainty interviews, which are described in Chapter 5.1.

Chapter 4

Methods

4.1 Background

4.1.1 Physics 2130 Course Description

The laboratory sections used for this study were chosen from the spring 2013 first semester calculus-based physics course at The University of Toledo titled Physics 2130, *Physics for Science and Engineering Majors*. Physics 2130 instructs as many as 300 students each semester in the standard first-semester physics material: kinematics, Newton's laws, momentum, energy, rotational motion, and thermodynamics. Conveniently, in this study, there was only one lecturer for all of these students who taught the same material to each section, so every student had the same lecture experience. The recitation was taught by three instructors including myself and two other experienced teaching assistants (TAs). While minor differences between instructors cannot be accounted for, the students were instructed to complete the University of Washington's *Tutorials in Introductory Physics* (McDermott & Shaffer, 2002) for their recitation, which had no variance between recitations. Also, students in each laboratory were distributed between all recitations sections, so small discrepancies between recitation instructors were distributed evenly throughout the data.

4.1.2 Laboratory Demographics

To create a comparative study between Scientific Learning Community (SLC) laboratories and Traditional laboratories, three sections of SLC laboratories and four sections of traditional laboratories were selected. Each student self-selected his or her laboratory time. No indication of laboratory type (SLC versus traditional) was given to the students while signing up for their laboratory section, so there were no self-selection concerns for the student populations in each section. As many as eighteen students were allowed to fill each laboratory section.

The three SLC laboratories ran weekly on Tuesday from 8:00 until 9:50, Tuesday from 1:00 until 2:50, and Thursday from 5:00 to 6:50. These sections were selected somewhat at random based on my availability for the semester. Being the only laboratories I was teaching that semester, only three were selected. I have had two years of experience teaching Scientific Learning Community Laboratories and eight years of experience teaching various aspects of introductory physics. All students in the SLC laboratories were invited to participate in the research, a total of fifty-two students. Participation in each portion of the study was optional so the number of students involved in the FCI, E-CLASS, and interviews vary as indicated in Table 4.1, Table 4.2, and Table 4.3.

Table 4.1: The number of students who participated in the pre-test, post-test and both the pre-test and post-test of the Force Concept Inventory.

Laboratory Type	Pre-Test	Post-Test	Both Pre-Test and Post-Test
Traditional (N=71)	N=42	N=31	N=29
SLC (N=52)	N=39	N=24	N=24

Table 4.2: The number of students who participated in the pre-test, post-test and both the pre-test and post-test of the E-CLASS.

Laboratory Type	Pre-Test	Post-Test	Both Pre-Test and Post-Test
Traditional (N=71)	N=24	N=27	N=18
SLC (N=52)	N=27	N=34	N=22

Table 4.3: The number of students who participated in oral or written interviews, for interview 1, interview 2, and interview 3 of the uncertainty interviews.

Laboratory Type	Traditional Laboratory (N=71)	SLC Laboratory (N=52)
Interview 1	12	6
Oral	6	6
Written	6	0
Interview 2	8	6
Oral	5	5
Written	3	1
Interview 3	3	5
Oral	3	5
Written	0	0

The four traditional laboratories ran weekly on Monday from 12:00 until 1:50, on Monday from 3:00 until 4:50, on Wednesday from 12:00 until 1:50, and on Friday from 12:00 until 1:50. I coordinated with all four Teaching Assistants (TAs) teaching Physics 2130 laboratories that semester and selected one laboratory per TA. Two of the TAs had one year of teaching experience with the traditional laboratories and two of the TAs had two years of experience teaching the traditional laboratories. One laboratory section for each TA was chosen to maintain a similar sample size to that of the SLC laboratories. A total of 71 students were invited to participate in this research. As previously noted, participation in each portion of study was optional, so the number of students involved in the FCI, E-CLASS, and interviews varied (see Table 4.1, Table 4.2, and Table 4.3).

Since this study was conducted in a calculus-based introductory physics course which contains around 90% engineering majors, all sections of these laboratories had similar demographics. The demographic survey was not completed by all students in each laboratory type, as attendance to laboratory on that specific day was a factor in who took the demographic survey. Of the 71 potential students in the traditional labs, 57 were in attendance that day, giving an 80% attendance rate for that specific mid-semester day. For the SLC labs, 47 of the 52 potential students were in attendance that day, yielding a 90% attendance rate for the same set of days. While not ideal, these 80%-90% of the students should be mostly representative of each laboratory type as a whole. The results of this survey are detailed in Table 4.4.

Table 4.4: Demographic Survey Results describing number of participants by gender, age, year in school, previous physics experience, major, and ethnicity.

Demographic Category	Number of SLC Participants (N=47)	Number of Traditional Lab Participants (N=57)
Gender: Male	40	39
Gender: Female	7	18
Age 18	10	19
Age 19	26	24
Age 20	4	4
Age 21	2	1
Age 22+	5	9
Year in School: 1	37	44
Year in School: 2	6	5
Year in School: 3	1	3
Year in School: 4	3	3
Year in School: 5+	0	2
No Previous Physics Experience	10	6
Previous Physics Class Taken	37	51
Major: Engineering	45	50
Major: Physics	1	3

Major: Chemistry	1	2
Major: Undecided	0	1
Major: Psychology	0	1
Ethnicity: White	44	46
Ethnicity: Asian	2	2
Ethnicity: African American	1	2
Ethnicity: Indian	0	2
Ethnicity: Middle Eastern	0	3
Ethnicity: Latino	0	2

As confirmed through the demographic survey, a vast majority of students were white, male, and between the ages of 18-20. Most were first-year engineering students with some form of previous physics experience. The specific demographics for both laboratory types are labeled in Figure 4 - 1. Due to the similarities in the demographics between the SLC and traditional laboratories their effects are considered to be negligible for this study, though may be investigated further at a later date.

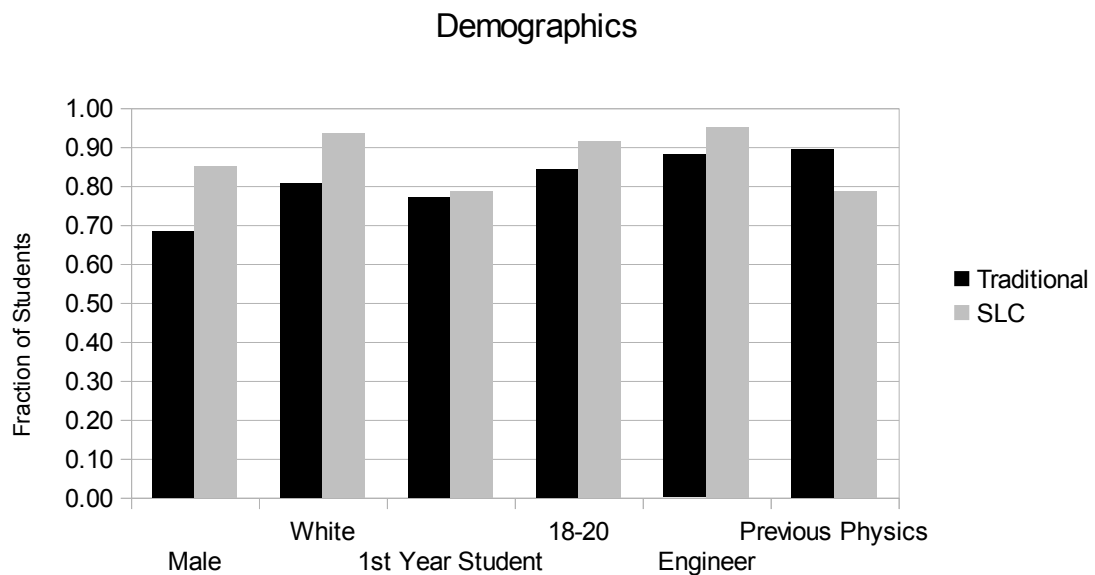

Figure 4 - 1: Summary of the Demographics of SLC and traditional laboratory sections

4.1.3 Traditional Laboratories

Traditional laboratories at The University of Toledo use Realtime Physics (Sokoloff & Thornton, 2007) as the basis for each laboratory. There are a total of twelve two-hour laboratories covering the standard introductory physics topics and concepts in each laboratory. These laboratories have been modified throughout the years to accommodate our university's various needs and are significantly different than the original Realtime Physics laboratories. Many edits to the manual were needed to make the laboratories run more smoothly for students and instructors alike. Text has been added for instructing students on which file to open, how to use the equipment, how to calibrate the equipment, which equations to use, where to graph data, and other sorts of information they need to complete the laboratory. Simultaneously, text that was not needed, did not fit, or was confusing for students was removed from the manual. From the laboratory manual alone, students are mostly able to complete the laboratories.

An unfortunate side effect of adding this information is that there are fewer places in the laboratory manual where students do not have enough information and are forced to think through a question and come to an answer. Students are given so much information that, much like what the University of Maryland discovered in their traditional laboratory observations (Reddish & Hammer, 2009) students spend much of their time on the logistics of the laboratory and little time making sense of the laboratory.

Throughout the laboratory, eight groups of two to three students each complete the laboratory in their two hour allotted time. In practice, however, laboratories take around an hour to finish. After a short introductory lecture from the TA, students follow

the laboratory manual to collect and process data to answer questions in the laboratory manual.

The grade that is given to the students mostly reflects attendance, with a small emphasis on performance. Two points are given to a student who completes the laboratory as long as they are not late or misbehaving throughout the laboratory. There is also one half point per laboratory given for the completion of their pre-laboratory before class. Due to the shortened time duration of laboratories and grades only pertaining to a student's attendance and completion the laboratory, it is my experience that the goal of many students is to complete the laboratories in order to leave as soon as possible. Even with the threat of having to repeat the data collection if it was done in a sloppy manner, many students will attempt to rush through the data collection and shortcut the questions in the laboratory manual to finish as early as possible.

While it is the instructor's job to curtail these habits, the way the laboratory is structured leads to this kind of student behavior. In the student's mind, the way they are graded establishes the main goals of the lab: attendance and completion. Their actions reflect this, as often students attempt to do their data collection as quickly as possible in order to complete the laboratory.

There are no tests or reports due, so the only indication that there was any understanding of the material takes place in the few minutes the instructor is able to look through the laboratory manual and check the group's answers. Each group is working at their own pace, and apart from the introduction, the students never come together to discuss the laboratory. With eight groups needing to be looked after, it is very possible that many mistakes could be missed during these manual checks. Those students could

leave the laboratory with misunderstandings of the material or even misconceptions that they have confirmed through sloppy experimentation.

As an example of a typical traditional laboratory, to compare with the SLC version, I will describe the projectile motion laboratory. In this laboratory students are meant to derive the range equation before class so they can use it during class. In practice, many of the students fail to do the derivation correctly, so often the TA must go over the derivation at the beginning of laboratory. In case students still do not understand the derivation, the range equation is listed in the manual, and an explanation of how to use it is given. After that, the laboratory has students shooting a ball ten times at an angle of 30 degrees to calculate the initial velocity of the launcher. Then students are meant to input that velocity back into the range equation to find the distance the ball will travel with a launch angle of 60 degrees. The manual then has the students shoot ten shots at 60 degrees to verify that they get this distance. If they do not get the “correct” distance, the students are asked to discuss why their results are off from the expected result.

Traditional laboratories place students in a frame where they follow procedures and achieve the correct answer to conceptual physics questions. Their actions reflect that frame, as data acquisition and interpretation are primary goals of those laboratories. Little to no emphasis is placed on understanding the nature of experimental physics, and in the worse cases a student may leave thinking that one data point plugged into a valid equation is enough to determine a result. These views are consistent with someone with an empiricist epistemology regarding physics (Lippmann, 2003) and point paradigm thinking (Lubben, 1996).

The activities in these laboratories are consistent with the previously discussed traditional laboratory designation (The President's Council of Advisors on Science and Technology, 2012). From this point forward I will be referring to the laboratories at the University of Toledo as traditional laboratories.

4.1.4 Scientific Learning Community Laboratories

Scientific Learning Community (SLC) laboratories were derived from The University of Maryland Scientific Community Laboratories (SCL). Using their ideas and the logistics of our pace and equipment needs, I have designed a custom fit version of the SLC laboratories for The University of Toledo. This customization does not preclude other universities from adopting these laboratories. The pace of the laboratory follows a very common flow of physics content consistent with many introductory physics books and concurrent with the timings of the Real-Time Physics laboratories. Most of the equipment needed for this laboratory includes the standard variety of motion detectors, force probes and projectile launchers that already appear in many introductory physics laboratories. For a full description of the equipment needs and pace of the SLC laboratories, please refer to the SLC laboratory manual (Appendix A).

The University of Maryland SCL laboratories were designed to put students in a frame where the actions they were taking were those of a research scientist. This was in an attempt to keep a consistent epistemological tone throughout their entire introductory physics course at The University of Maryland (Reddish & Hammer, 2009). The laboratories are structured such that students have the freedom to design and defend their own experiment to answer physics questions. I have followed this framework closely when designing the SLC laboratories. Students in the SLC laboratories must design and

defend their own experiments in an attempt to teach concepts and change the way they think about experimental physics.

The day-to-day logistics of the SLC laboratories also mirror the SCL logistics. In the first session, the initial five minutes are spent discussing basic class logistics. A small overview of when things are due or an analysis of the places people lost points in the laboratory reports will take place during this time. Five to ten minutes is spent setting up the problem for the day and introducing the equipment that the students have access to during the class. Then, students are expected to brainstorm, discuss possible solutions, play with the equipment, collect data, find answers, and estimate errors with only a small amount of guidance from their instructor. The only other source of help given to the students is the guiding questions in their SLC laboratory manual (Appendix A). This section asks students more general questions to try to edge students onto the right track for tackling the project of the day. At no time does anything or anyone give them step-by-step instructions on how to complete the laboratory. Much of the thinking and developing of methods and ideas is up to the students.

The function of the laboratory instructor is to visit students' groups and discuss the groups' ideas. If problems are foreseen with the path a group is taking, the instructor can (but does not have to) push students in a different direction by asking them questions that may help them troubleshoot potential problems in their experimental design.

Somewhere after the first hour of the first session, the instructor facilitates a discussion regarding the ideas of each laboratory group. The attempt is to try to get the students to discuss and agree on answers to the more difficult design questions from that laboratory. Once these discussions conclude, students are expected to get to a set design

by the end of the day. This design, while possibly not entirely fleshed out, is meant to answer the question of that day. The detail of the design can be explored more during the second session.

I added an extra assignment to the SLC laboratories that is not present in the SCL design. Due to the group sizes being sometimes greater than four students, I have designed a homework assignment meant to be completed between the first and second session. To make sure all students in the group had the same understanding of the laboratory, the mid-session homework asks students questions about the experimental design and the physics surrounding the design. This addition is the only deviation between the logistics of the SLC laboratories and the SCL.

During the second session students are given ten to fifteen minutes to go over the answers to each student's mid-session homework with their group members. This helps refresh the students on the previous week's laboratory, makes sure everyone has the similar content knowledge and gets them thinking about the problem this week. Then 30 to 45 minutes is given to the students to recreate their experimental setup from the previous week, collect data regarding their setup, and to estimate the statistical and systematic error present in their setup. After students investigate the uncertainties in their experiment, they are asked to give a short presentation regarding their experimental design, data, and conclusions based off of the results for their experiment. Students from other groups are required to reflect on those presentations and critique, much like the peer review process. Since most are well versed in the laboratory by this point, small discrepancies in design have the potential to become significant conversation pieces of the class.

After the second session, students are tasked to create a laboratory report about the previous two-session laboratory. They are required to explain their design, collected data, and conclusions in detail. The teacher acts as a final peer reviewer, judging whether the report involved a consistent logical argument with a conclusion that followed from the results. Points are generally taken from groups who fail to make their case effectively. This grading emphasizes the importance of the experimental process, and not just the results achieved. Once concluded, groups then have to complete a group laboratory report about their methods and their findings. This laboratory report is meant to detail their design methods and logic throughout the entire experimental process.

An important example of the SLC laboratories can be described through one of its experiments, projectile motion. Students are given a projectile launcher and asked to learn about its properties through experimentation. The main goal is for the students to be able to understand their launcher and the physics pertaining to it. They must learn enough about it to be able to hit a target on the first shot, every time. Meter sticks, goggles, carbon paper, and the three basic kinematics equations are given to the students, and they are left to explore the launcher in their groups.

Often students start by just playing around with the projectile launcher. Many students will begin firing and testing it out until they are comfortable with their launcher. The questions in the laboratory manual and TA guide students toward thinking about their process, and after some time students find they must create an experiment to determine the initial velocity of the projectile launcher. After some tests, students are able to find the initial velocity, split it up into components, and use that information to calculate the distance the projectile will travel. By the end of session 1, students are

expected to be able to find the initial velocity of their launcher and use it to mathematically predict where the ball will land.

For the second session, students are already comfortable with how to calculate information using physics equations and can readily achieve answers for the distance the projectile will travel. A large focus is placed on how well they know the numbers they are using in their equations. This focus leads to students characterizing the discrepancies between multiple trials that have the same initial condition and into a discussion of variability and random error. Students use their data to create error bars for their launch distance. Now that they know the center and the extremities of their launch distance, they are able to take educated shots and hit the target almost every time.

The groups must give a presentation about the experiment they use to determine the distance the projectile travels. The presentation is centered on trying to convince other groups of their experimental process, calculations, error estimates, and results. If there are discrepancies, other groups ask questions or make suggestions pertaining to what they could have done differently. After each presentation, the group demonstrates hitting the target, and achieves this goal nearly every time.

Due to the mirrored design of the laboratories and the equivalent class structure, the SLC laboratories, by design, reflect the architecture of the SCL laboratories. Teaching these laboratories during the semester, I have followed the structure of each laboratory (described above) to the letter. My execution of these laboratories represents the ideal version of the laboratories, in line with the work that has previously been done at the University of Maryland.

A common issue in education research, especially in comparative studies is the teacher effect. It explains potential differences between groups with different teachers as due to their teacher being a better, or more experienced teacher than the teachers in the other group. While this criticism is important, my reflective execution of the SLC laboratories suggests that the laboratories themselves are the effective utensil, and not the teacher of the laboratory. The work I have done to mimic the SCL laboratories in every way can go a long way to showing that the differences between laboratory types is due to executing these laboratories effectively rather than just teaching ideally. To confirm this inference however, a potential follow up study involving teaching both laboratories with the same TA could be in order.

Both laboratory types instruct students on uncertainty and data analysis, yet both do this instruction in a manor specific to the laboratory type. Traditional laboratories expect the directions in the laboratory manual to instruct students on the intricacies of uncertainty. SLC laboratories expect students to discover the uncertainty of their procedure by analyzing multiple data points to account for the variability of their experiment. The method which students learn the most expert-like version of uncertainty will be answered through this dissertation.

4.2 Instruments

Three main instruments were used to gauge changes in student conceptual knowledge and attitudes: the Force Concept Inventory (FCI), the Colorado Learning Attitudes about Science Survey for Experimental Physics (E-CLASS), and interviews regarding conceptual understanding of uncertainty.

4.2.1 Conceptual Knowledge

Student conceptual understanding of laboratory physics was measured using two different instruments. First, concepts taught through both physics lecture and physics laboratories were measured using the Force Concept Inventory (FCI) (Hestenes, Wells, & Swackhamer, Force Concept Inventory, 1992). The FCI was chosen because it is the oldest and most widely used conceptual test in the literature. Second, concepts taught exclusively through laboratory were measured using the uncertainty interviews.

The FCI is a thirty-question multiple-choice test measuring students' conceptual knowledge of Newtonian physics. It was administered in the recitation section of the Physics 2130 course on both the first and last day of recitation, which occurred the first and last week of the semester. Each recitation occurred on Thursday of the semester, so students did receive three days of physics instruction prior to taking the test, however, this delay is unlikely to have affected the results of the pre-test as most of those days covered the introduction to physics, units and measurement, whereas the FCI covers topics from later portions of the course, such as Newton's laws and motion. After the post-test was taken, students received no additional physics instruction, so these results should reflect their conceptual knowledge upon leaving the course. Both sections of the course were given the same material at the same time, so there should be no discrepancies between data sets. Since this test was an established part of the course all regularly attending students completed this survey. As attendance in recitation was often around 70%, the data set is nearly complete for both tests. Unfortunately, a student had to have attended both the pre-test and post-test to consider the change in their conceptual knowledge, so only around 50% of students were present in the final data set for each

laboratory. The number of participants who completed the FCI pre-test, post-test and both appear in Table 4.1. There may be a bias towards regularly attending students; however this bias was present in both data sets, so they are comparable.

4.2.2 Understanding of Uncertainty

Examining the change in students' understanding of uncertainty gives a metric regarding their procedural understanding of experimental physics. The Physics Measurement Questionnaire (Buffler, Allie, Lubben, & Campbell, 2001) does not change between pre-test and post-test, and expects a small amount of physics content knowledge from the student. Also, to determine whether the answers students give are through memorization, or understanding of physics, the questionnaire also requires interviews with students. Due to this requirement, I decided to bypass the questionnaire and developed my own set of interview questions that change concurrently with the students' laboratory content knowledge. The initial interview pertained to real-world experiences that did not require physics content knowledge. The later interviews discussed topics the students had experienced in their laboratory. These questions did require some content knowledge to be able to answer. The first set of interviews discussed a pitching machine pitching balls at unknown heights and being able to predict the height the ball will cross the plate. Since some students had not had any experience with physics previous to this point, this interview was meant to draw on knowledge developed outside of physics class. In contrast, the second interview was developed to draw on information that students in both laboratory types had interacted with through their physics laboratory. It described shooting a ball from a projectile launcher to find the initial velocity. The third interview described another circumstance from both physics laboratories: a cart being accelerated

by a hanging weight. While each interview described different circumstances the questions probed the same information in the same order. So on the surface the tests seemed different to the students, but in reality, they were very much the same. See Appendix C, E, and G for the full set of interview prompts.

These interviews were completed on the third week of the semester, the ninth week of the semester and the seventeenth week, representing close proximity to the beginning, middle, and end of the semester, respectively. During the second and third interview three additional questions were added to the survey. The first two questions asked the student what experiences (laboratory or otherwise) led them to their answers to the questions during the interview. The third new question asked how their perspective on science had changed due to their laboratory experience. This helped establish when their change in knowledge had occurred.

Two interviewers were used to conduct the interviews through the semester. The interviewer for each interview was chosen based on which laboratory students were in and who their recitation instructor was. The intention was to keep a student from having to interview with their current instructor. Any student who had either interviewer as their recitation or laboratory instructor was interviewed by the other interviewer. If a student had both interviewers as instructors, they were invited to complete a written interview. The written interview served as backup data and gave students the opportunity for the extra credit afforded by this study. Students who completed one of the interviews earned half of a point of extra credit toward their thirty-point laboratory grade total.

Due to the difficult nature of scheduling and executing interviews a maximum of six were allotted for each section and interview set. If more students wanted to

participate in interviews than these times allowed a written interview was provided to that student. The numbers of participants for each interview who took either the oral or written survey are described in detail in Table 4.3. Near the end of the semester participation diminished greatly. The survey given for the written interviews appear in Appendix D and F.

4.2.3 Attitudes

To examine the change in students' attitudes with regard to experimental physics, The Colorado Learning Attitudes about Science Survey for Experimental Physics (E-CLASS) (Zwickl, Finkelstein, & Lewandoski, 2013) was administered electronically through The University of Colorado website. A collaborator handled setting up the data collection website and processing the data. Students were invited to log on to the website and take the pre-test and post-test at the third and seventeenth week of the semester, respectively. Both surveys were open for one week each. Students who completed a pre-test or post-test received half of a point of extra credit towards a thirty-point laboratory grade total. This prompted less than half of the students in each section to take the survey. Exact numbers for how many students have taken each test appear in Table 4.2.

4.3 Data Analysis

4.3.1 Conceptual knowledge

The goal of running the FCI was to investigate if there was a difference between traditional and SLC laboratories with regards to physics concepts discussed in both laboratory and lecture. FCI pre-tests and post-tests for both the SLC laboratories and the

traditional laboratories were tabulated. Using these numbers, a change in FCI score was calculated for each student using their pre-test score, minus their post-test score. The normalized gain for each student was then calculated with the formula: $g = (post-pre)/(100-pre)$, where *pre* represents the percentage score on the pre-test and *post* represents the percentage score on the post-test. This gain is a measure of the change in a student's score (post-test score percentage minus the pre-test score percentage) divided by their maximum possible change in score. This calculation allows a comparison to be made between students' scores that are independent of their score on the pre-test. An average and standard deviation of all student normalized gains from each laboratory type was taken to find the average normalized gain for each laboratory type.

Additionally, the average of all pre-test scores and change in score was also calculated using all available data for each set. Lastly, the standard deviation was calculated for traditional and SLC pre-test scores, post-test scores, and the change in score from pre-test to post-test.

4.3.2 Understanding of Uncertainty

Interviews were conducted to track the change in student understanding of uncertainty. These interviews were transcribed using audio recordings. A coding scheme, synthesized from Lubben (1996), which is described in chapter 3.3, was implemented to code the transcripts. I have added to the hierarchy in order to encompass the idea of systematic error, as well as an indication of point and set paradigm ideas from Buffler et al. (2001). The levels have been changed from A-H to a numeric system (1-9), and a term describing from which paradigm the reasoning was derived has been added to the level. For the purposes of simplicity in this dissertation, the level, described by Table

4.5, will be called the Lubben Level. Simultaneously, another column was added to the hierarchy to describe how a student would interpret his or her results if they conflicted with a known answer. This column was meant to gauge a student's understanding of systematic error and incorporate that idea into the hierarchy. An additional row was also added to account for students with understanding of outliers, but not a complete understanding of systematic error. The final coding scheme for all interviews is presented in Table 4.5.

Table 4.5: Lubben Level Coding Scheme for Interviews Analysis

Lubben Level	View of the process of measuring (multiple measurements)	How to evaluate your result (statistical error)	What to do with anomalous results (outliers)	If results conflict with known answers (systematic error)
1 Point	Measure once and you get the true value.	Not an issue - a measurement is correct	Not an issue.	Human Error
2 Point	Measure once and take this as the right answer. Any result is likely to be as good as any other, so repeating is useless.	Unless something has obviously gone wrong, a measurement is correct. In familiar contexts, your result should be close to what you would expect.	Not an issue.	Human Error
3 Point With Set Ideas	If you have adequate equipment and are careful, your measurement will be right. Take a few trial measurements to practice and then take your final measurement.	Unless something has obviously gone wrong, a measurement taken with practice will be correct. In familiar contexts, your result should be close to what is expected.	Ignore. (Differences are due to different amounts of practice.)	Human Error

4 Point With Set Ideas	If you have adequate equipment and are careful, your measurement will be right. Repeat trials to get the same result twice.	Getting the same value twice shows you have measured carefully enough.	Ignore.	Human Error
5 Point With Set Ideas	Repeat a measurement and take the average. Repeating the measurement exactly will give the same result, so change conditions slightly each trial.	Variation is to be expected. Not an issue.	Variation is to be expected. Include all values in calculating an average	Correct Conditions will give correct results, must change conditions
6 Set	Careful measurements may be close to the true value but you can never be sure you have found it. Take an average to allow for this variation.	Cannot be evaluated from 'inside'. Only method is to check with an authority (i.e., teacher or textbook).	This is why we calculate an average – it takes care of the differences	Spread of data can account for error, Just unlucky results
7 Set	as above	Can be evaluated from 'inside'. The spread of the measurements is an indication.	as above	Loss in the system somewhere, can't or don't account for it
8 Set	as above	as above	Exercise judgment to reject anomalous results before averaging. The mean or mode of some data sets may be better.	Loss in the system somewhere, can't or don't account for it

9 Set	as above	as above	as above	Loss in the system somewhere, must account for the discrepancy between answers
----------	----------	----------	----------	--

Each interview was coded using the Lubben Level scheme and the averages and standard deviations were calculated for each laboratory type and for each interview to show the progression of students' understanding of uncertainty throughout the semester.

4.3.3 Attitudes

The Colorado Learning Attitudes about Science Survey for Experimental Physics (E-CLASS) was conducted to demonstrate changes in students' attitudes throughout the semester. The pre-test and post-test data was collected and processed through a website created by The University of Colorado. Students rated their attitudes on a five-point Likert scale ranging from "strongly disagree" to "strongly agree." While taking each test, students indicated the answer they thought a physicist would give on top of their own answer to each question. Each response given was coded as expert-like if it agreed with the opinion of an expert. For answers where experts agreed with a response, student answers of four and five were considered expert-like. For answers where experts disagreed, responses of one and two were considered expert-like responses.

The fraction of students with expert-like thinking for each question was calculated by dividing the number of students who indicated expert-like thinking by the total amount of students who took that survey. This calculation was done for both the pre- and post-test as well as for each laboratory type. Simultaneously, the fraction of students

with expert-like responses to questions asking their opinion of a physicist was calculated. The fraction of expert-like responses on all questions was averaged for both laboratory types. Additionally, the Pearson correlation coefficient for each laboratory type was calculated, comparing each student's average expert-like responses for themselves with average expert-like responses for their opinion of what a physicist would say.

Based on the similar types of questions on the E-CLASS survey, it may seem like there are natural categories that arise. The authors of the E-CLASS survey indicate that researchers should look at each question individually for information regarding student attitudes rather than attempt to categorize these questions (Zwickl, Hirokawa, Finkelstein, & Lewandowski, 2013). Due to this lack of categorization, every question was evaluated individually for the fraction of expert-like thinking. For the both laboratory types, as well as the pre-test and post-test, the average fraction of expert-like thinking for all students was calculated as well as the standard deviation. Since expert-like thinking was reported as a zero or a one, the range of possible values was omitted; zero to one would be the expected range for all questions.

4.3.4 Statistical Significance

The paired two-tailed t-test was performed between pre and post versions of the FCI and E-CLASS to determine if the changes seen in each survey were statistically significant. This analysis is meant to show if the differences between the pre-test and post-test for the traditional and SLC laboratories are the product of pure chance or if the results are statistically significant.

4.3.5 Correlations

A correlation between changes in FCI score and Lubben Level was calculated for each student with scores in both categories. Additionally, a correlation between the fraction of expert-like thinking on the E-CLASS post-test and the Lubben Level was calculated. The Pearson correlation coefficient was not usable since removing a laboratory type from the calculation would result in a notably different Pearson correlation coefficient. The partial correlation coefficient was chosen to evaluate the possible connections. This coefficient removes the effect of laboratory type and looks exclusively at the correlation between understanding of uncertainty, conceptual changes and attitude changes.

Chapter 5

Results

5.1 Force Concept Inventory

Both populations achieved a similar average and a similar standard deviation on the FCI pre-test. The traditional laboratories' FCI pre-test score averaged 47.5% with a standard deviation of 18.1% while the SLC laboratories pre-test scores averaged 46.5% with a standard deviation of 18.9%.

Students in the traditional laboratories increased their conceptual score on average by 9.0% after a semester of introductory physics. In contrast, students in the SLC laboratories' average score increased by 19.2%. The average normalized gain for the traditional laboratories was $\langle g \rangle = 0.17$ while the SLC laboratories achieved $\langle g \rangle = 0.36$. As expected, the increased change in score resulted in a higher average normalized gain for the SLC laboratories. The summary of these results appears in Table 5.1.

Table 5.1: Summary of FCI Scores and Hake Number of Traditional and SLC Labs

	Mean (%)	σ	Range (%)
Traditional Labs			
Pre-Test Score (N=42)	47.5	18.1	6.67 to 83.3
Change in Score (N=29)	+9.0	11.3	-6.67 to 30.0
Normalized Gain (N=29)	0.17	0.249	-0.40 to 0.583
SLC Labs			
Pre-Test Score (N=39)	46.5	18.9	16.6 to 96.6
Change in Score (N=24)	+19.2	11.6	0 to 40
Normalized Gain (N=24)	0.36	0.248	0 to 1

5.2 Uncertainty Interviews

Three interview sets to examine student understanding of uncertainty were conducted, transcribed, and coded (as described in chapter 4.3.2). A summary of the data is recorded in Table 5.2 and the results are plotted in Figure 5 - 1.

Table 5.2: Lubben Level between SLC and Traditional laboratories

	Mean Lubben Level	σ	Range
Traditional Labs			
Interview 1 (N=6)	6.0	1.8	3 to 8
Interview 2 (N=6)	4.5	2.6	1 to 9
Interview 3 (N=5)	3.4	2.3	1 to 7
SLC Labs			
Interview 1 (N=12)	6.9	1.4	5 to 9
Interview 2 (N=8)	7.4	1.9	3 to 9
Interview 3 (N=3)	8.7	0.57	8 to 9

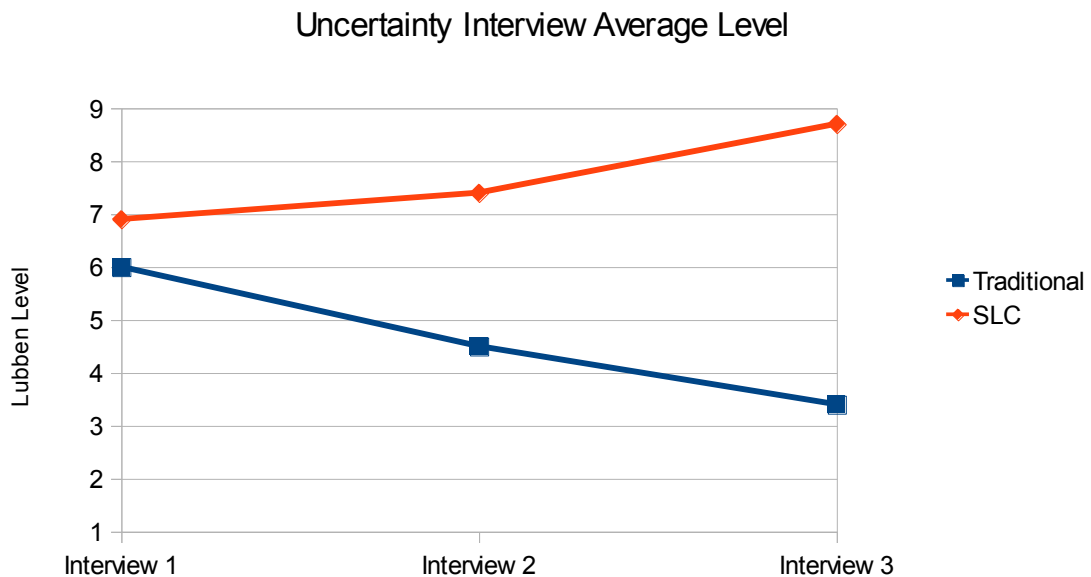

Figure 5 - 1: Average Lubben level from each uncertainty interview.

In the first interview, when asked about calculating the correct height to hit a ball in batting cages, students were mostly able to apply what they knew about variability and the real world to answer questions consistently well. Students in the SLC laboratories received a Lubben level of 6.9 and students in the traditional laboratories received an average Lubben level of 6.0. SLC interview 1.2 gives a good example of this understanding of uncertainty. When asked if the height of their predicted swing could be different than the height that the ball crosses the plate, the student answered: “It is hard to throw it the exact same every time. If it throws it at a different velocity from the first time it is going to be a different height.” Similarly, students in the traditional laboratories were able to describe the variability of the pitching machine. Discussing the same question, traditional interview 1.4 answered: “...the way the machine tosses it might not be exactly the same.”

As students progressed through their physics laboratory, their understanding of uncertainty began to change. When asked about shooting a projectile launcher into the air to calculate the initial velocity during the second interview, students began to answer very differently. For example, in traditional interview 2.2, the student was asked how accurate the calculated range of the projectile would be. That person replied “I think it is basically right.” Then when asked how they would validate the range of the projectile, the student responded “I’d use the formula, another formula to make sure.” An example of a student response to the same question from SLC interview 2.5: “It is only one trial and the launcher has a lot of variation.” Students in the traditional and SLC laboratories earned an average Lubben level of 4.5 and 7.4 respectively.

By the end of the semester, students had completely divergent views on uncertainty. In the traditional laboratories, the average Lubben level ended at 3.4 whereas in the SLC laboratories, average Lubben level increased to 8.7. Interview 3 asked about using a hanging mass accelerating a cart to find the mass of an unknown mass. During the third interview, for example, when given a data point and an equation, students in the traditional laboratories gladly plugged that data point into the equation to achieve an answer. When asked about the validity of the answer, most said that as long as the data was collected precisely and the equation was good, the answer was completely valid. An illustrative quote from traditional interview 3.2:

“Interviewer: If you were able to do this experiment with greased ball bearings and no friction and no air resistance, would this be a valid...what would you say about the validity of this?

Student: Then it would be good, accurate.

Interviewer: Is it possible that this number is off from the mass of the object? What could have caused this inaccuracy? What would that do to the mass?

Student: No, I think if this equation is the right one, then it should be good.

Interviewer: How would you validate this number?

Student: I don't understand, this equation is proven, right?"

For comparison, students given a single data point in the SLC laboratories would often insist that their answer needed more data points to be considered valid. Before even being asked, students were uniformly able to identify the lack of experimental validity of one data point. An example from SLC interview 3.1:

“Interviewer: You run a test and get an acceleration of 1.36 m/s^2 . Using your formula, you calculate the mass of the unknown mass to be 158 grams. How valid is your answer?

Student: Not very valid, unless you ran it a few more times, to see if you keep continually getting that answer through multiple trials.

Interviewer: If I asked you what the mass of the unknown mass what would you tell me?

Student: Umm...based off of a whole bunch of trials, the average of all of the trials...cutting off outlier. So, we don't know yet, because we only have one trial.”

Students were then given a set of acceleration data. When asked about why there were different answers, despite not changing the test, students in the SLC laboratory could identify the natural variability of the situation. Students in the traditional laboratories often could not comprehend the discrepancies and would try to claim that the experiment did change slightly between trials due mainly to friction and air resistance.

When asked what value they would use from all of these trials, students from both laboratory types could identify that the average of the data points would achieve one final answer. In general, students in the traditional laboratories were able to execute some of the mathematical operations of uncertainty, but their logic on the previous sections of the interviews was dissonant with this information. If a student could not identify that one needed multiple data points, yet was able to do the mathematical operations for multiple data points, they fell into the point paradigm on the Lubben scale. SLC students were

generally consistent between their explanations and mathematical operations, so the generally fell much higher on the Lubben scale.

After telling students that the experimental value was sizably different than the mass of the unknown object, the interviewer asked students to do the experiment again with a different, unknown mass. Students in both laboratories mainly mentioned that they would do the same test over again. A notable few students at the SLC laboratories were able to identify that there would be a systematic error that would need to be accounted for in the new trial. An exemplary quote from SLC interview 3-2:

Interviewer: You are given a new unknown mass. Not changing anything about your contraption or equations and without weighing it, how would you test this new unknown mass? Be specific and list every step you would take to achieve the correct mass.

Student: I would, from the last experiment, nothing changed. I would take the error between the average number I got and the actual number and calculate that error. Then I would find the average of a new data set with the new mass. I would take the error from the actual to the average from the last experiment. Then, using that percentage of error, I would apply it to the new data and then do the same thing to get new error bars.

The last question asked students if their laboratory experience changed their views on how science is conducted. This was very illuminating, not because students reported a sizable change in thinking, but because it gave interesting insights into students' thinking about the SLC laboratory. I leave this section with three quotes from SLC students regarding the last question on the interview.

SLC interview 2.3

“Interviewer: Learn What?

Student: Teach ourselves these equations, how to find it, how to work out stuff. It is not just handed to us, we don't just calculate this and plug in numbers, we actually have to figure out what equations to use, how far to set it up and test it to see if we are right. It is kind of like real world experience, like testing and research.

Interviewer: And you like this?

Student: I do.”

SLC interview 2.1

“Student: Yeah, it’s like....my laboratories were just kind of like, go figure it out. And I liked it a lot better. It made me think and it made me be more of a problem solver. So you aren't given an answer...and I like figuring stuff out even though it is a lot more difficult and it take a lot more time. It hurts my head sometimes, it gets really frustrating sometimes, but in the end it helped me. Not only in laboratories, but on tests and stuff like that. I can sort of go through everything I know and try to find a solution. I think doing laboratory where you just are kind of pushed and not given the answer and not given the step by step what to do, I think it just makes you more of a creative thinker. I love that.”

SLC interview 3.2

“Student: In pretty much every laboratory was trying to figure out the error bars and accounting for error, because there is always going to be error in experiment. The experiment is not going to be 100% correct with theory most of the time. In this laboratory, we are always pushed to do our own thing and make a huge data set and figure out the error bars in that data set. Don’t try to fix the error unless it is giant, but try to account for your error.”

5.3 E-CLASS Survey

Changes in students’ attitudes were tracked through a pre-test and post-test of the E-CLASS survey. The average fraction of students’ expert-like thinking was calculated based on all question responses (Table 5.3) as well as the standard deviation. Students in traditional laboratories had an insignificant decrease in expert-like thinking from pre-test to post-test. Students in the SLC, however, had a fair increase in expert-like thinking between the pre-test and post-test, indicating that, on average, SLC students had an increase in attitudes regarding experimental physics.

Table 5.3: E-CLASS expert-like thinking regarding student opinions of themselves.

	Mean Fraction of Expert-Like Thinking	σ	Range
Traditional			
Pre-Test (N=24)	0.682	0.129	0.367 to 0.867
Post-Test (N=26)	0.670	0.137	0.367 to 0.900
SLC			
Pre-Test (N=27)	0.697	0.120	0.433 to 0.867
Post-Test (N=34)	0.755	0.102	0.533 to 0.900

When looking at responses of students to questions regarding what they think a physicist would say (Table 5.4), there was a similar increase in expert-like thinking in students who participated in the SLC laboratories. This increase indicates that students in the SLC laboratories had an increase in understanding of the attitudes of an experimental physicist.

Table 5.4: E-CLASS expert-like thinking regarding student opinions of a physicist.

	Mean Fraction of Expert-Like Thinking	σ	Range
Traditional			
Pre-Test (N=24)	0.818	0.117	0.400 to 0.933
Post-Test (N=26)	0.808	0.137	0.367 to 0.967
SLC			
Pre-Test (N=27)	0.808	0.095	0.600 to 0.933
Post-Test (N=34)	0.847	0.089	0.633 to 0.967

An interesting relationship appeared between students' attitudes and their opinion of physicists' attitudes during the E-CLASS post-test. By plotting a graph of students' attitudes versus students' opinion of physicists' attitudes, the connection is clear. Students in general answered that physicists' attitudes were more expert-like than their

own attitudes. In the traditional laboratories however, the difference between the two was much larger and much more inconsistent than in the SLC laboratories.

Students who participated in traditional laboratories (Figure 5 - 2), were aware of what an expert-like physicist answers would be; however, those students' attitudes were much more separated from those known answers. Students with low attitudes and high attitudes all knew of the expert-like physicist response, yet did not confirm these attitudes about themselves. The correlation between the two was a low $r = 0.20$, meaning there was little connection between students' attitudes and their opinion of physicists' attitudes.

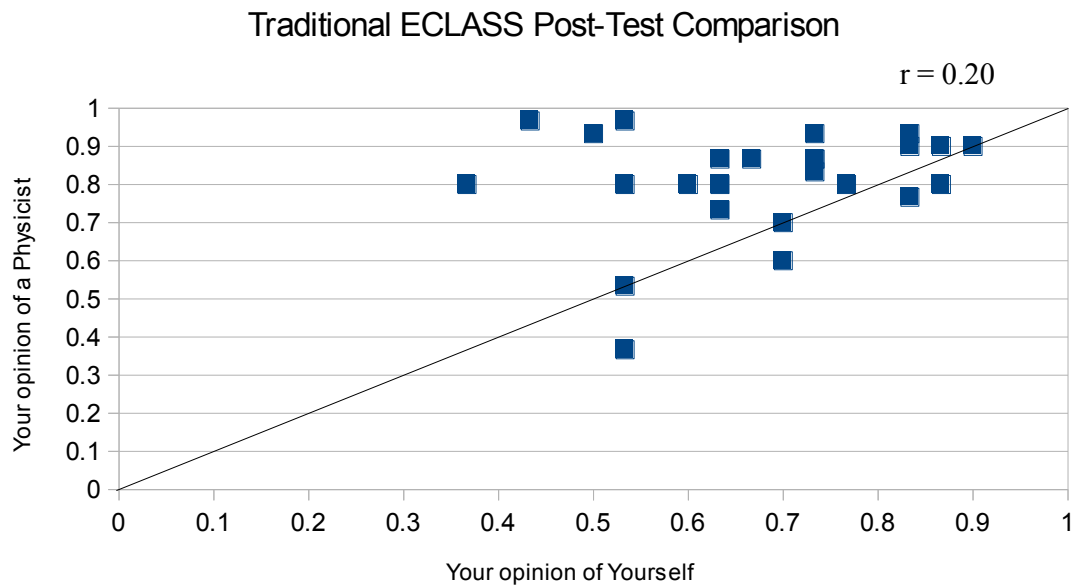

Figure 5 - 2: Traditional laboratory correlation between students' attitudes and their opinion of physicists' attitudes.

On the other hand, students in the SLC laboratories (Figure 5 - 3), had opinions of themselves that were relatively consistent with what they regarded a physicist's answers

to be. These equal x-axis and y-axis values are represented by the line through the graph. The correlation between the two for the SLC laboratory was a high $r = 0.76$. The SLC students had a strong relationship between their attitudes and what they regarded physicists' attitudes to be.

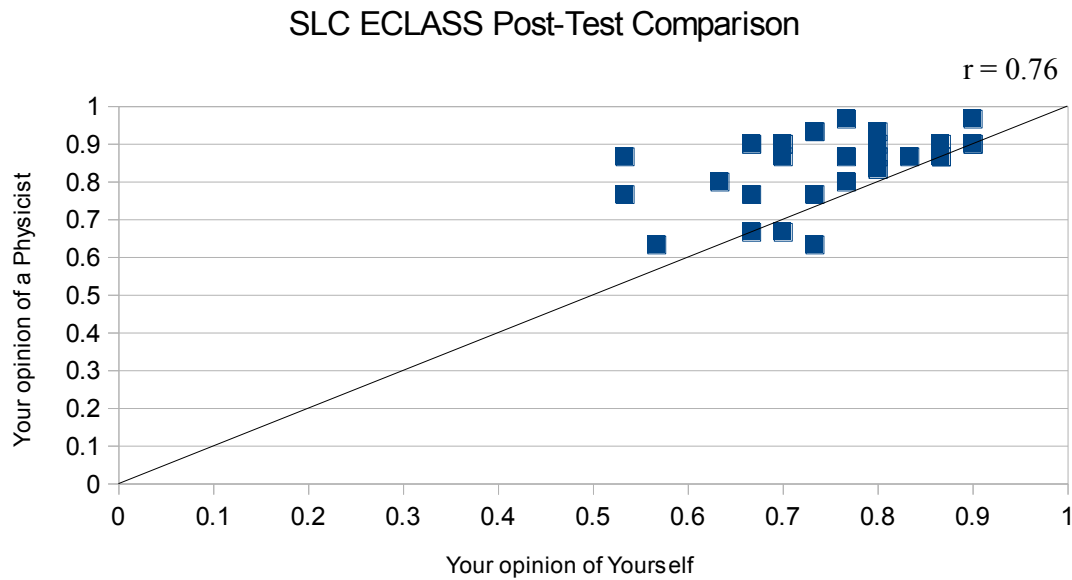

Figure 5 - 3: SLC laboratory correlation between students' attitudes and their opinion of physicists' attitudes.

Table 5.5 and Table 5.6 displays the average fraction of expert-like responses and standard for every question on the E-CLASS survey. Table 5.5 reports expert-like thinking for the traditional laboratories and Table 5.6 reports expert-like thinking for the SLC laboratory.

Table 5.5: Fraction of expert-like thinking for each question in the E-CLASS survey for the traditional laboratory

		Pre-Test Fraction of Expert-Like Thinking	Post-Test Fraction of Expert-Like Thinking
Question 1	Mean	0.917	0.885
	σ	0.147	0.130
Question 2	Mean	0.667	0.731
	σ	0.289	0.253
Question 3	Mean	0.500	0.615
	σ	0.243	0.221
Question 4	Mean	0.917	0.923
	σ	0.132	0.129
Question 5	Mean	0.667	0.692
	σ	0.183	0.196
Question 6	Mean	0.417	0.654
	σ	0.215	0.210
Question 7	Mean	0.333	0.385
	σ	0.257	0.246
Question 9	Mean	0.583	0.462
	σ	0.248	0.247
Question 10	Mean	0.833	0.769
	σ	0.215	0.190
Question 11	Mean	1.000	0.962
	σ	0.000	0.103
Question 12	Mean	0.917	0.962
	σ	0.152	0.110
Question 13	Mean	0.292	0.231
	σ	0.204	0.228
Question 14	Mean	0.625	0.500
	σ	0.183	0.221
Question 15	Mean	0.708	0.769
	σ	0.207	0.169

Question 16	Mean	0.208	0.154
	σ	0.297	0.242
Question 17	Mean	0.833	0.615
	σ	0.175	0.287
Question 18	Mean	0.750	0.692
	σ	0.224	0.183
Question 19	Mean	0.542	0.346
	σ	0.228	0.208
Question 20	Mean	0.708	0.731
	σ	0.196	0.163
Question 21	Mean	0.917	0.923
	σ	0.131	0.152
Question 22	Mean	0.208	0.192
	σ	0.252	0.240
Question 23	Mean	0.792	0.846
	σ	0.179	0.170
Question 24	Mean	0.833	0.577
	σ	0.186	0.217
Question 25	Mean	0.875	0.923
	σ	0.166	0.181
Question 26	Mean	0.958	0.885
	σ	0.106	0.133
Question 27	Mean	0.667	0.692
	σ	0.189	0.193
Question 28	Mean	0.833	0.769
	σ	0.241	0.219
Question 29	Mean	0.667	0.692
	σ	0.257	0.211
Question 30	Mean	0.292	0.192
	σ	0.254	0.226
Question 31	Mean	1.000	0.962

Σ	0.000	0.116
----------	-------	-------

Note. The numbers of students responding is the same for each question. Pre-tests contain N=24 responses, and post-tests contain N=26 responses.

Note. Since answers to all questions are marked as expert-like or not expert-like using a 0 or a 1, the range of data for all questions is from 0 to 1.

Note. Question 8 was a check to see if students were reading the questions and has been omitted from the data table.

Students who participated in traditional laboratories gave responses for question 3 and question 6 with notably higher change in expert-like thinking. Question 3 reads, “When doing a physics experiment, I don't think much about sources of systematic error” (Perkins, Granty, Adams, Finklestein, & Wieman, 2005, p. 2) and question 6, “Calculating uncertainties usually helps me understand my results better” (Perkins, Granty, Adams, Finklestein, & Wieman, 2005, p. 3).

Simultaneously, the fraction of students’ expert-like thinking decreased notably on two of the questions: question 17 and question 19. Question 17 on the E-CLASS post-test reads “A common approach for fixing a problem with an experiment is to randomly change things until the problem goes away” (Pollock, et al., E-CLASS Post-Test, 2014, p. 5) and question 19, “Scientific journal articles are helpful for answering my own questions and designing experiments” (Pollock, et al., E-CLASS Post-Test, 2014, p. 5).

Table 5.6: Fraction of expert-like thinking for each question in the E-CLASS survey for the SLC laboratory

	Pre-Test Fraction of Expert-Like Thinking	Post-Test Fraction of Expert-Like Thinking
--	---	--

Question 1	Mean	0.963	1.000
	σ	0.116	0.000
Question 2	Mean	0.778	0.735
	σ	0.229	0.259
Question 3	Mean	0.593	0.706
	σ	0.203	0.270
Question 4	Mean	0.815	0.912
	σ	0.169	0.167
Question 5	Mean	0.704	0.794
	σ	0.188	0.205
Question 6	Mean	0.630	0.794
	σ	0.205	0.171
Question 7	Mean	0.370	0.441
	σ	0.222	0.248
Question 9	Mean	0.593	0.676
	σ	0.222	0.261
Question 10	Mean	0.852	0.971
	σ	0.184	0.113
Question 11	Mean	0.815	0.912
	σ	0.208	0.140
Question 12	Mean	0.852	0.912
	σ	0.178	0.167
Question 13	Mean	0.407	0.412
	σ	0.193	0.191
Question 14	Mean	0.667	0.676
	σ	0.184	0.257
Question 15	Mean	0.630	0.941
	σ	0.227	0.165
Question 16	Mean	0.296	0.324
	σ	0.253	0.287
Question 17	Mean	0.741	0.647

	σ	0.196	0.267
Question 18	Mean	0.963	0.912
	σ	0.140	0.149
Question 19	Mean	0.333	0.471
	σ	0.260	0.232
Question 20	Mean	0.815	0.853
	σ	0.155	0.183
Question 21	Mean	0.926	0.912
	σ	0.150	0.165
Question 22	Mean	0.111	0.059
	σ	0.181	0.191
Question 23	Mean	0.889	0.824
	σ	0.179	0.227
Question 24	Mean	0.667	0.588
	σ	0.229	0.308
Question 25	Mean	0.852	0.794
	σ	0.163	0.202
Question 26	Mean	0.963	0.912
	σ	0.108	0.221
Question 27	Mean	0.889	0.824
	σ	0.138	0.167
Question 28	Mean	0.667	0.853
	σ	0.232	0.213
Question 29	Mean	0.815	0.853
	σ	0.189	0.240
Question 30	Mean	0.370	0.382
	σ	0.200	0.256
Question 31	Mean	0.963	0.941
	σ	0.108	0.191

Note. The numbers of students responding is the same for each question. Pre-tests contain N=27 responses, and post-tests contain N=34 responses.

Note. Since answers to all questions are marked as expert-like or not expert-like using a 0 or a 1, the range of data for all questions is from 0 to 1.

Note. Question 8 was a check to see if students were reading the questions and has been omitted from the data table.

SLC students' attitude changes towards seven statements accounted for much of their increase in expert-like thinking. Recall that expert-like thinking on a question does not necessarily mean that students agreed with the statement, just that they held an expert-like view regarding the question. These seven statements were: "3. When doing a physics experiment, I don't think much about sources of systematic error" (Pollock, et al., E-CLASS Post-Test, 2014, p. 2), "4. It is helpful to understand the assumptions that go into making predictions" (Pollock, et al., E-CLASS Post-Test, 2014, p. 2), "6. Calculating uncertainties usually helps me understand my results better" (Pollock, et al., E-CLASS Post-Test, 2014, p. 3), "10. When doing an experiment, I try to understand the relevant equations" (Pollock, et al., E-CLASS Post-Test, 2014, p. 4), "15. Designing and building things is an important part of doing physics experiments" (Pollock, et al., E-CLASS Post-Test, 2014, p. 5), "19. Scientific journal articles are helpful for answering my own questions and designing experiments" (Pollock, et al., E-CLASS Post-Test, 2014, p. 5), and "28. When I approach a new piece of lab equipment, I feel confident I can learn how to use it well enough for my purposes" (Pollock, et al., E-CLASS Post-Test, 2014, p. 7). No notable decline in fraction of expert-like thinking was calculated on any question for SLC laboratory students.

5.4 Correlations

The partial correlation between change in FCI score and Lubben Level was calculated for each student with scores in both categories, yielding $r = 0.11$. This value indicates that the conceptual changes examined in the FCI are not correlated to conceptual changes examined in the uncertainty interviews. These results are represented graphically in Figure 5 - 4.

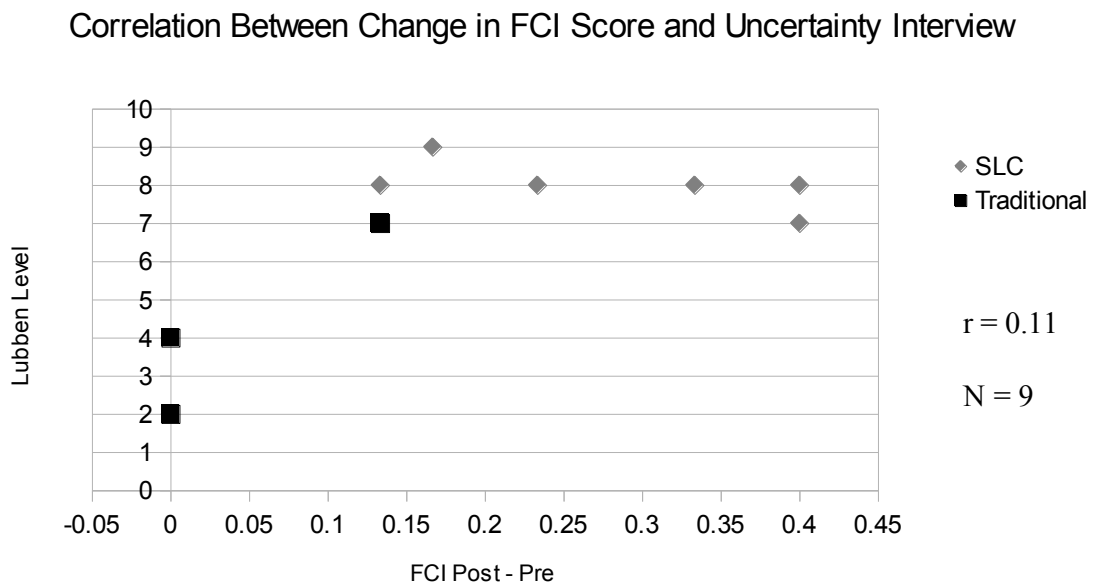

Figure 5 - 4: Correlation between physics conceptual knowledge and understanding of uncertainty.

Additionally, a correlation between the fraction of expert-like thinking on the E-CLASS post-test and the Lubben Level was calculated, resulting in $r = 0.59$. The fraction of expert-like thinking of the E-CLASS has a strong correlation to the concepts examined in the uncertainty interviews. This correlation means that there remains a moderately strong relationship between students' attitudes and their conceptual understanding of

uncertainty that is independent of which laboratory they participated. These results are represented graphically in Figure 5 - 5.

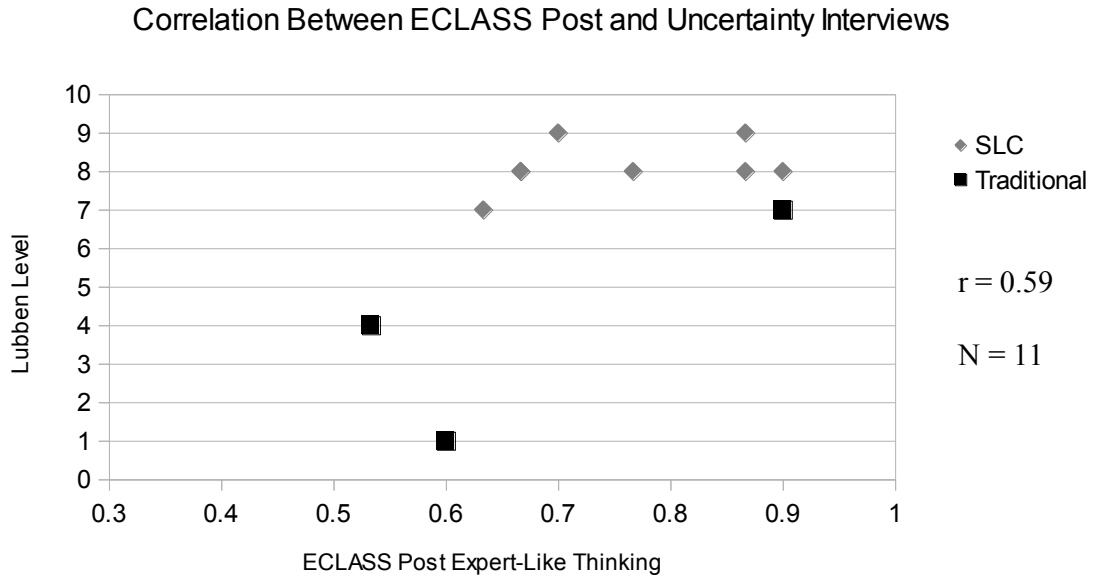

Figure 5 - 5: Correlation between student attitudes and understanding of uncertainty.

5.5 Statistical Significance

The following table (Table 5.7) presents the probability that the change in students' scores on the FCI and E-CLASS happened by chance. If the paired *t-test* results indicate a $p < 0.05$, they are considered statistically significant. All results show statistical significance of $p < 0.05$ except for the change in E-CLASS in the traditional laboratory. Change in FCI score, and change in E-CLASS for the SLC laboratories show statistically significant results. The average change in expert-like thinking for the traditional E-CLASS was almost non-existent, so the fact that no change could happen by chance is not unexpected.

Table 5.7: Paired *t-test* results between pre-test and post-test for the FCI and E-CLASS.

	Paired <i>t-test</i> results
Traditional	
FCI	0.00016
E-CLASS	0.418
SLC	
FCI	$8.91 \cdot 10^{-8}$
E-CLASS	0.0313

Chapter 6

Discussion

6.1 Conceptual Gains

A possible concern about the Scientific Learning Community (SLC) laboratories is that if students are not directly taught the concepts, how will they learn them? In traditional laboratories students have to interact with many of the concepts, and are vaguely evaluated based on whether they understood the concept of the day. The SLC laboratories expect students to interact with the concepts through their project, but they are never directly asked specific concept questions. For example, nowhere in the projectile motion laboratory does it ask students to consider velocities as separate in the x-direction and y-direction. However, students find it simplifies the calculation of the initial velocity if they launch the projectile in only one of the dimensions. They can then extend their understanding of the projectile in one dimension to describe the motion of the ball in two dimensions as a combination of two one-dimensional motions.

By comparing the average normalized gain achieved through the FCI, we can put each laboratory type in the greater context of physics education research. The traditional laboratories ($\langle g \rangle = 0.17$) fall into the low gain category, whereas the SLC laboratories ($\langle g \rangle = 0.36$) are near the low end of the medium gain range. In Hake's analysis (1998),

traditional physics classes (which house traditional physics labs) typically achieve an average normalized gain of $\langle g \rangle = 0.23$, in the low gain range, whereas classes that use interactive engagement methods can range anywhere between $\langle g \rangle = 0.3$ and $\langle g \rangle = 0.7$, defined as medium gains (Hake, 1998). The University of Toledo Physics laboratories yielded results in line with average traditional classes. The SLC laboratories, however, achieved an average normalized gain on the low end of the medium gain range. The SLC laboratories achieved gains similar to those found in lectures that use interactive engagement techniques. A recent study done on first-year calculus-based physics students at the University of Toledo describe similar results (Shan, 2013). Implementing interactive engagement techniques in lecture achieved an average normalized gain of $\langle g \rangle = 0.32$, in the low range of medium gains achieved by the results achieved by this study.

These results show that the laboratory reforms are achieving similar FCI gains to those achieved using interactive engagement lectures. While slightly surprising, these results fit with the connections described in the literature between the way students think about learning physics and the way they study and understand the conceptual component physics. For example, May (2002) describes that the epistemologies of his students accounts for 70% of his students' FCI gains. This study did not directly evaluate the epistemologies of its students, so no claim can be made as to connection between epistemologies and conceptual gains in these laboratories. I will suggest that the emphasis placed on student epistemologies in the design of the SCL laboratories may be part of the impetus behind these conceptual gains. In any case, these discovery-based laboratories show an improved conceptual understanding of physics in its students when compared to traditional laboratories.

6.2 Uncertainty Interviews

By testing for a student's understanding of uncertainty using Lubben Levels (Lubben, 1996) one can examine if the student is reasoning from point or set paradigm (Buffler, Allie, Lubben, & Campbell, 2001) and gain insight into potential student epistemologies (Lippmann, 2003).

SLC laboratories expect students to maintain a level of accuracy (e.g. hitting the center of a target) that requires them evaluate the statistical and systematic error of their experiment. Through this process students learn about data processing and evaluating their error as part of the experimental process.

The traditional laboratories require students to measure multiple data points, find systematic error, and discuss variability as part of the laboratory manual. Specifically, students are asked to collect multiple data points and average them together, calculate the error in their answer by comparing it to the "correct" answer, and find the uncertainty of their answer by estimating the possible data collection errors. While our traditional laboratories often discuss ideas of error and uncertainty, it is done using traditional, verification laboratory techniques. The laboratory manual prompts students with explanations and equations to do calculations and complete the data analysis. The point of comparison between the two laboratories is which technique for learning error will prove the most fruitful.

Examining the average Lubben level for each interview offers insight into which paradigm each laboratory type represented. Traditional laboratories and SLC laboratories started with an average Lubben level around six and seven respectively. As the semester progressed, the Lubben levels for both laboratories diverged sizably from one other.

Students in traditional laboratories, declined to an average Lubben level of 3.4. Students in the SLC laboratories maintained their high Lubben level, averaging 8.7 by the end of the semester. This result indicates that students in the traditional laboratories were mostly thinking from the point paradigm, whereas students in the SLC laboratories were mostly thinking from the set paradigm.

Students in the traditional laboratories were able to plug in the numbers and get answers, much like Sere (1993) described, yet those students held many misconceptions about uncertainty that put them into Buffler's (2001) point paradigm. Based on Lippman's (2003) description of the epistemologies of physics students, students with this level of understanding of the uncertainty of experimental physics are likely to hold empiricist epistemologies. While the logic follows from the literature, the epistemology of students cannot be established directly through this study.

Student interviews detail some of these misconceptions. By the end of the semester, many reported that if they were given a valid equation, they could calculate answers for their experiment that are perfectly accurate. Traditional interview 2-2 suggests that instead of seeking multiple data points to validate a number that student would rather find another equation to validate results. The example given in traditional interview 3-2 suggests a belief that if the experimental setup is perfect, the calculated number is valid, and no scenario can be considered where it is not valid. Despite these misconceptions, students in traditional laboratories that were given multiple data points understood immediately that they needed to average the points, as taught to them by their laboratory manual, again, reflecting Sere's (1993) experience with teaching students uncertainty in traditional laboratories.

Students who both understand and can execute the mathematical intricacies of uncertainty may realize that physics is not concrete, but fluid and variable. These views are consistent with a constructivist's views of learning (Lippmann, 2003) as well as the ideas of the set paradigm (Buffler, Allie, Lubben, & Campbell, 2001).

Students in the SLC laboratories had a much more coherent understanding of uncertainty. They were able to do the necessary math while they simultaneously described why multiple data points were collected. These beliefs put them within Buffler's (2001) set paradigm. Using Lippman's (2003) description of the epistemologies of physics students, this group is likely to hold constructivist epistemologies. Again, there is no direct evidence of student epistemologies throughout this study, so I will forgo making any conclusions based on this information.

Transcripts from the SLC interviews confirm this understanding of uncertainty. Students are able to identify that experiments have natural variability, such as in SLC interview 2-5. When asked if a single answer is valid, most suggest that multiple data points are needed before being able to confirm the answer. In SLC interview 3-1 the student suggests that this one data point may not be valid, and only if you get the same answer continually could you confirm the number. Students were also able to identify and apply their systematic errors to new circumstances, such as in interview 3-2.

Understanding of uncertainty was shown to increase in the SLC laboratories and decrease in the traditional laboratories. Traditional physics laboratories seemed to teach students that correct equations with correct numbers will achieve a correct answer, and one experimental data point and a valid equation is enough to determine properties of an experimental setup. Students in SLC laboratories were thinking in terms of set paradigm

and achieved higher average Lubben Levels. This suggests that the discovery-based laboratories, such as SLC laboratories, yield a stronger understanding of uncertainty when compared to traditional laboratories.

6.3 Attitude Changes

Student attitudes were heavily affected by their laboratory section. Students in the SLC laboratories showed a greater change in their interest and a greater change in their attitudes through their laboratory course. Their attitudes about experimental physics were aligned with experts eight percent more often than their traditional laboratory counterparts.

Responses to specific questions where students' attitudes increased through the semester indicate that students had increased confidence when approaching the design and the development of an experiment. These results make sense, as these topics were an important part of the SLC laboratory. The discovery-based laboratory was able to improve students' attitudes about their ability to create and conduct experiments. Students also had better attitudes regarding analyzing data, and understanding the uncertainty in their experiment. Understanding data processing and uncertainty was again an important part of the SLC laboratories so improved attitudes with regards to this key part of a physics laboratory are consistent. It is an important result that the SLC laboratory was able to develop students' confidence and attitudes with their ability to take on the role of an experimental physicist. These results reflect the (Russell, Hancock, & McClough, 2007) results that discovery-based research in the first two years of a student's undergraduate degree increases students' attitudes regarding physics.

The decisive gains that students in the traditional laboratory achieved on the E-CLASS survey were also regarding understanding uncertainty. While, their opinions about their understanding of uncertainty improved, their Lubben level on average decreased through the semester. It is likely that their thoughts on uncertainty changed into their considering uncertainty as “how far off they are from the correct answer” much like what Coelho & Sere (1998) found in their study. This simplified version of uncertainty would relate to students feeling as though they understood their results by measuring how discrepant it was from the correct answer.

Simultaneously, students had reduced attitudes with respect to how to conduct an experiment. They reported that fixing problems generally involves randomly changing things until the problem goes away. This is counter to the small methodical changes that are expected of expert-like physicist when facing a problem in the laboratory. The decline is possibly due to students having less independence in their laboratory to understand their equipment and experiment due to the rigid nature of the laboratory manual. Students may not have had the proper tools to troubleshoot problems as they arose.

Interestingly, both groups indicated a large fraction of expert-like responses when asked to answer on behalf of a physicist, indicating that both groups were aware of the expected responses of a physicist. Student answers regarding their opinion of a physicist deviated from their own responses far less in the SLC laboratories, and were highly correlated. In the traditional laboratories, the correlation between answers on behalf of physicists and answers describing their opinion of themselves were extremely weak. Students in traditional laboratories deviated far more between their answers groups. It

was apparent that the traditional students were aware of the answers an experimental physicist would give to these questions; they just did not hold these same attitudes. Students in SLC laboratories both understood the answers an experimental physicist would give and reflected those answers in their own attitudes, indicating that students' attitudes were consistent their version of an expert-like physicist. This result is similar to what Reddish (2009) discusses: students in reformed physics classes split their answers less often than students in traditional physics classes.

6.4 Correlations

The low partial correlation ($r = 0.11$) between conceptual knowledge of general physics and understanding of uncertainty indicates that the two are not connected well. This result seems to indicate that the two content areas are separate from one another and learned independently through laboratory or lecture.

The relatively high correlation ($r = 0.59$) between attitudes regarding experimental physics and understanding of uncertainty indicates there is a strong relationship between the two. This relationship is independent of laboratory type. The correlation found is stronger than the ones found by Perkins, Adams, Pollock, Finkelstein, & Wieman (2004) as well as by Milner-Bolotin, Antimirova, Noack, & Petrov (2011); however, it mirrors the relationship between conceptual physics learning and attitudes found in both papers. These results extend the correlation between content learning and attitudes into the territory of laboratory physics. The lack of data in this correlation (only eleven data points) weakens conclusions based on this information. Future studies of this topic may bring more concrete conclusions.

6.5 Limitations

Due to time limitations and personnel limitations, there are many possible biases that potentially affect this research. Sample size, student self-selection, teacher effect, and researcher effect are all possible limitations of this research.

6.5.1 Sample Size

The number of students for each laboratory type was sizable to begin this study. As different tests and surveys were executed throughout the semester, those numbers began to diminish, as only a portion of the full body of students participated in each.

The FCI had a reasonable turnout for both the pre-test and the post-test. The problem came when finding students who took both the pre-test and post-test. This diminished the numbers of students to 24 and 29 students for the SLC and traditional laboratories, respectively. This is a reasonable number of students, with a chance error of 20% or less. The FCI test results of this study are mirrored by another study (Shan, 2013) done on first-semester calculus-based introductory physics students at the University of Toledo, giving some additional confidence to the results.

Having no authority to make students take these surveys as part of a laboratory, I was unable to secure a large sample of students on the E-CLASS survey. Similar to the FCI, fewer students participated in both pre- and post-test, weakening calculations based on the change in attitudes of the students. The smallest amount of students participating on the E-CLASS was 24, with a chance error of around 20%.

The interviews were intentionally kept at smaller numbers of students due to the logistics of scheduling interviewers and interviewees. Being the only person in the

physics department researching education, it was difficult to secure help with the logistics of the study. People who conduct interviews must be trained and pass human subjects tests, all of which are not trivial. If this study were to be executed in a department with a larger network of physics education researchers, it would be far more practical to execute these interviews with higher numbers of students. Also, forgoing the interview in the middle of the semester would make the logistical aspect of this study easier to accomplish, and may yield more continued participation, and less research fatigue from the students.

6.5.2 Self-Selection

Self-selection of students may have been a factor in the results. For the FCI, students were selected based on whether they were in class that day, so there may have been a selection for regularly attending students. The E-CLASS was conducted through a website, and students were able to go to the website within a one week window to complete their survey. This sample may have been skewed towards student who are either interested in the research, or in need of extra credit on their laboratory. The interviews likely had the same biases, though they may also have been biased towards students who are more social students, or students who are more comfortable with interviews. All of these effects are likely to be uniform between both laboratory types.

6.5.3 Teacher Effect

Few teaching assistants have been trained in the facilitation of the SLC laboratories, and none were assigned to the calculus-based laboratories during the semester this research was being conducted. I was the only teaching assistant teaching the SLC laboratories, and the primary researcher of this study. It is possible that I am

indeed a more successful or motivated instructor than the traditional laboratory teaching assistants. Due to this lack of personnel, and my obvious interest in seeing the SLC laboratories succeed, a teacher effect was possibly present during this research.

At the time of the study I had had two years of experience teaching these laboratories. The teaching assistants teaching the traditional laboratories had minimally over one year of experience teaching these laboratories. This similarity of experience may have mitigated some of the teacher effect present. Additionally, the goal of this research was to execute an ideal version of these laboratories using the design elements from the University of Maryland's Scientific Community Laboratories. To mitigate this effect in future research, the primary researcher would have to be separated from the teaching of this laboratory. This would involve training teaching assistants and engineering their teaching duties so that they would be teaching said laboratories, an unfortunate impossibility for this study.

6.5.4 Researcher Effect

The main researcher of this study was engaged in the execution of some aspects of this study, so a researcher effect may be present. Due to the lack of personnel, it was impossible to separate the main researcher from the day-to-day aspects of this study.

Both the E-CLASS survey and the FCI should not show any researcher effect, as the researcher had no part in the administration of those surveys. The uncertainty interviews may have had some researcher effect, since the primary researcher conducted those interviews.

The design of the study partially mitigated the researcher effect by having no interviewer interviewing his or her own students. The main researcher was in charge of

interviewing only students who participated in the traditional laboratories, so any unintentional leading that may have occurred would have been present in the traditional laboratory data, and not the SLC laboratory data. Removing this effect in future research would require additional researchers to conduct interviews to separate the primary researcher from the interviews.

6.6 Implications

This study points to some recommendations for the implementation of Scientific Learning Community laboratories as a physics department's calculus-based introductory laboratory. Reforming traditional laboratories by implementing Scientific Learning Community laboratories has the potential to increase students' conceptual knowledge, understanding of uncertainty, and attitudes regarding laboratory physics. These reforms come with small changes to a department's laboratory organization, described below.

A department wishing to implement these laboratories likely already has many of the materials needed, including motion detectors, force probes, carts, ramps, pulleys, known masses, and photogates. These materials are the same as the ones needed to execute most basic physics labs, including the Realtime Physics labs (Sokoloff & Thornton, 2007). Small additions, such as a looped track, may be needed to complete the materials for the laboratory. The full supply list is located in the front matter of the laboratory manual located in Appendix A.

Implementing these laboratories department-wide would require a weekly meeting, led by a head laboratory instructor, where reflection and training would occur. This practice was used by The University of Maryland with their Scientific Community

Labs, and is a recommended practice for new laboratory instructors (Reddish & Hammer, 2009). New instructors require training in how to properly act as a facilitator and less of a teacher for the students in the laboratory.

As with most education reforms, teaching assistants and laboratory organizers must spend more time due to the added training and discussion group. Also, since each laboratory spans two sessions, less material will be able to be covered in a semester. The SLC laboratories cover the content of kinematics, projectile motion, energy, circular motion, momentum, and oscillations; however topics such as fluids, thermodynamics are omitted due to time constraints.

6.7 Future Research

This study was conducted on students in a calculus-based introductory physics class that contained mostly engineers and physics majors. These students have a high initial interest and expert-like attitudes regarding experimental physics (as confirmed by the E-CLASS survey). Also, the large majority of the class is composed of engineering majors who may enjoy the freedom that comes with designing their own experiment more than the typical first-year student. These students may respond better to the SLC laboratories, as the things they do in the laboratory are likely aligned with their career goals and aspirations.

The next natural extension of this research would be to conduct a study on introductory physics students in the algebra-based section of the class. These students are mainly biology, pre-med, or pre-pharmacy students and may not respond similarly to the SLC laboratories. It is possible that student buy-in to the ideas and activities of the SLC

laboratory is a large part of its current success. Algebra-based physics also contains a much more diverse group of students. While our calculus-based class is mostly white males, the algebra-based class contains much larger subsections of differing races, genders, and experience levels. These topics will be left to explore in a future study.

This study poses many new questions as well, they may merit future research. The FCI results were striking, but little indication was given as to why students improved their conceptual knowledge through the semester. Parsing the FCI results into the conceptual categories may describe the conceptual areas that students are excelling as compared to the traditional laboratories. These gains in specific categories may correlate to a specific sessions of the SLC laboratory. Finding the successes of the FCI laboratories may indicate ways to improve other laboratories and yield further conceptual gains in students.

On the E-CLASS survey, students in the traditional laboratories split their answers often when asked what a physicist would say and what they would say. A follow-up to this would be finding which questions students split more often on, and why they split their answer. This investigation may show some places that the traditional laboratories could improve, and show some of the successes of the SLC laboratories.

6.8 Conclusion

I would like to reflect on the main research questions, and answer them based on the results of this study. The first three questions are related and can be answered simultaneously:

1. How do students' conceptual knowledge about physics differ between traditional laboratories and discovery-based laboratories?
2. How do students' attitudes regarding physics laboratory differ between traditional and discovery-based laboratories?
3. How do students' understanding of uncertainty differ between traditional and discovery-based laboratories?

Discovery-based laboratories increase expert-like thinking in students across all three categories: conceptual knowledge, attitudes, and understanding of uncertainty. Students in SLC laboratories had greater gains in their understanding of the concepts learned through lecture. Student understanding of uncertainty between traditional and SLC laboratories completely diverged between point and set paradigms respectively. Correspondingly, SLC laboratories Lubben level increased whereas traditional laboratories declined through the semester. Additionally, there was a notable increase in expert-like attitudes of students in SLC laboratories. All three of these types of learning demonstrate that students achieved a more expert-like thinking through SLC laboratories. Until now, these metrics have never been used to study discovery-based laboratories, and therefore the relationship between the implementation of discovery-based laboratories and the increase in expert-like thinking had not been shown.

4. Are there correlations between the changes in understanding of uncertainty and conceptual knowledge or attitudes regarding physics laboratory?

A correlation between understanding of uncertainty and attitudes regarding laboratory physics was found by examining both laboratory types simultaneously. Using the partial correlation, a strong correlation was found between student attitudes and their understanding of uncertainty. This extends the connection between lecture-based content and attitudes to the domain of laboratory attitudes and laboratory-based content. Additionally, there was little connection found between conceptual physics learning and understanding of uncertainty. Conclusions based on these correlations are somewhat weakened by the lack of data in both correlations. This relationship does reflect the correlation Perkins, Adams, Pollock, Finkelstein, & Wieman (2004) found through lecture. While the conclusion may be weak, it is consistent with the relationship found in lecture, and a likely extension of the results. This may be the first data bringing to light a previously undiscovered connection between student attitudes regarding laboratory physics and their understanding of uncertainty.

The discovery-based laboratories from the University of Maryland are new, underutilized, and mostly untested in terms of conceptual knowledge, attitudes and understanding of uncertainty. The increases in student understanding of concepts, attitudes, and uncertainty show that students maintained more expert-like positions by the end of their laboratory. This additional expert-like thinking has the potential to increase retention in a physics department and assist the country in closing its 1 million STEM major gap that it faces in the next decade. Implementation of these laboratories fulfills the PCAST recommendation for discovery-based laboratories and may be a small step in part of a country-wide reform of our traditional physics laboratories.

References

- Adams, W., Perkins, K., Podolefsky, N., Dubson, M., Finkelstein, N., & Wieman, C. (2006). New instrument for measuring student beliefs about physics and learning physics: The Colorado Learning Attitudes about Science Survey. *Physical Review Special Topics: Physics Education Research*, 2.
- American Association of Physics Teachers. (1998, October). The Goal of Introductory Laboratories. *Am. J. Phys.*, 483. Retrieved December 17, 2013, from aapt.org: <http://www.aapt.org/Resources/policy/goaloflabs.cfm>
- Barlow, A., & Villarejo, M. R. (2004). Making a difference for minorities: Evaluation of an educational enrichment program. *Journal of Research in Science Teaching*, 1-2.
- Bodner, G., Hunter, W., & Lamba, R. (1998). What happens when discovery laboratories are integrated into the curriculum at a large research university. *The Chemical Educator*, 1-20.
- Buffler, A., Allie, S., Lubben, F., & Campbell, B. (2001). The development of the first year physics students' ideas about measurement in terms of point and set paradigms. *Int. J. Sci. Educ.*, 1137-1156.
- Campbell, B. (1998). Realism versus Constructivism: Which is a More Appropriate Theory for Addressing the Nature of Science in Science Education. *Electronic Journal of Science Education*, 3:1.

- Coelho, S. M., & Sere, M. (1998). Pupils' reasoning and practice during hands-on activities in the measurement phase. *Research in Science & Technological Education*, 79-97.
- Feynman, R. P. (1964). *The Feynman Lectures on Physics*. Reading, MA: Addison-Wesley.
- Gilmer, T. C. (2007). An Understanding of the Improved Grades, Retention and Graduation Rates of STEM Majors at the Academic Investment in Math and Science (AIMS) Program of Bowling Green State University (BGSU). *Higher Education*, 8: 11-21.
- Hake, R. (1998). Interactive-engagement versus traditional methods: A six-thousand student survey of mechanics test data for introductory physics courses. *American Journal of Physics*, 64-74.
- Halloun, I., & Hestenes, D. (1985). The initial knowledge state of college physics students. *Am. J. Phys.*, 1043-1055.
- Halloun, I., & Hestenes, D. (1996). Views about Science Survey. St. Louis, MO: Annual Meeting of the National Association of Research in Science Teaching.
- Halloun, I., & Hestenes, D. (1998). Interpreting VASS dimensions and profiles for physics students. *Science and Education*, 553-577.
- Hestenes, D., & Wells, M. (1992). A Mechanics Baseline Test. *The Physics Teacher*, 159-166.
- Hestenes, D., Wells, M., & Swackhamer, G. (1992). Force Concept Inventory. *The Physics Teacher*, 141-158.

- Hofer, B. K. (2001). Personal epistemology research: implication for learning and instruction. *Ed. Psych. Rev.*, 629-639.
- Hunter, A.-B., Laursen, L., & Seymour, E. (2007). Becoming a scientist: The role of undergraduate research in students' cognitive, personal, and professional development. *Science Education*, 36-74.
- Kinkel, D. H., & Henke, S. E. (2006). Impact of undergraduate research on academic performance, education planning, and career development. *Journal of Natural Resources and Life Sciences Education*, 35: 194-201.
- Kung, R. L., & Linder, C. (2007). Metacognitive activity in the physics student laboratory: Is increased metacognition necessarily better? *Metacognition and Learning*, 41-56.
- Lippmann, R. F. (2003). *Students' understanding of measurement and uncertainty in the physics laboratory: Social construction, underlying concepts, and quantitative analysis*. University of Maryland, College Park: Proquest, UMI Dissertations Publishing. 3112498.
- Lopatto, D. (2007). Undergraduate research experiences support science career decisions and active learning. *CBE-Life Sciences Education*, 6: 297-306.
- Lubben, M. F. (1996). Children's ideas about the reliability of experimental data. *Int. J. Sci. Educ.*, 955-968.
- May, D. (2002). How Are Learning Physics And Student Beliefs About Learning Physics Connected? Measuring Epistemological Self-Reflection In An Introductory Course And Investigating Its Relationship To Conceptual Learning. (Electronic Thesis or Dissertation). Retrieved from <https://etd.ohiolink.edu/>.

- McDermott, L. C., & Shaffer, P. S. (2002). *Tutorials in Introductory Physics*. Upper Saddle River: Prentice-Hall Inc. .
- Milner-Bolotin, M., Antimirova, T., Noack, A., & Petrov, A. (2011). Attitudes about science and conceptual physics learning in university introductory physics courses. *Physical Review*, 020107:1-9.
- Nagda, B., Gregerman, S., Jonides, J., Von Hippel, W., & Lerner, J. (1998). Undergraduate student-faculty research partnership affect student retention. *The Review of Higher Education*, 22: 55-72.
- Perkins, K. K., Granty, M. M., Adams, W. K., Finklestein, N. D., & Wieman, C. E. (2005). Examining the Roles of Pre-college Beliefs about Physics and Learning Physics, Interest, and Academic Achievement . *Physics Education Research Conference*. Salt Lake City, Utah.
- Perkins, K., Adams, W., Pollock, S., Finkelstein, N., & Wieman, C. (2004). Correlating student beliefs with student learning using the colorado learning attitudes about science survey. *AIP*, (pp. 709, 61). Sacramento, California.
- Pollock, S., Perkins, K., Finkelstein, N., Dubson, M., Lewandowski, H., Beale, P., . . . Wilcox, B. (2014, February 12). *E-CLASS Post-Test*. Retrieved from PER@C: <http://www.colorado.edu/sei/surveys/E-CLASS/Sp12/E-CLASS-3-8-post-PHYS1140.html>
- Pollock, S., Perkins, K., Finkelstein, N., Dubson, M., Lewandowski, H., Beale, P., . . . Wilcox, B. (2014, Feb 12). *E-CLASS Pre-Test*. Retrieved from PER@C: <http://www.colorado.edu/physics/EducationIssues/AdvLab/E-CLASS/Sp13/Pre/E-CLASS-pre-Sp2013.html>

- Reddish, E. (1994). Implications of cognitive studies for teaching physics. *American Journal of Physics*, 796-803.
- Reddish, E. F., & Hammer, D. (2009). Reinventing College Physics for Biologists: Explicating an Epistemological Curriculum. *Am. J. Phys.*, 629-642.
- Reddish, E., Saul, J., & Steinberg, R. (1998). Student expectation in introductory physics. *American Journal of Physics*, 212-224.
- Russell, S., Hancock, M., & McClough, J. (2007). The Pipeline. Benefits of undergraduate research experiences. *Science* 316(5824), 548-549.
- Sere, M., Journeaux, R., & Larcher, C. (1993). Learning the statistical analysis of measurement errors. *Int. J. Sci. Educ.* , 427-438.
- Shan, K. (2013). Improving Student Learning and Views of Physics in a Large Enrollment Introductory. (Electronic Thesis or Dissertation). Retrieved from <https://etd.ohiolink.edu/>.
- Sokoloff, D., & Thornton, R. (2007). RealTime Physics: active learning labs transforming the introductory laboratory. *European Journal of Physics*, 583-594.
- Taylor, J. R. (1997). *An Introduction to Error Analysis (Second Edition)*. Sausalito, CA: University Science Books.
- The President's Council of Advisors on Science and Technology. (2012). *Engage to Excel: Producing One Million Additional College Graduates with Degrees in Science, Technology, Engineering, and Mathematics*. Washington, D.C.: Executive Office of the President.

- Thornton, R., & Sokoloff, D. (1998). Assessing student learning of Newton's laws: The Force and Motion Conceptual Evaluation and the evaluation of Active Learning Laboratory and Lecture Curricula. *American Journal of Physics*, 338-352.
- Tsai, C. C. (1998). An analysis of scientific epistemological beliefs and learning orientations of Taiwanese eighth graders. *Science Education*, 473-489.
- Wieman, C. (2012). Undergraduate Physics. *Building a Thriving Undergraduate Physics Program*. College Park, MD: American Physical Society.
- Wieman, C., & Perkins, K. (2005). Transforming physics education. *Physics Today*, 36-49.
- Zwickl, B. M., Finkelstein, N., & Lewandoski, H. J. (2013). Development and Validation of the Colorado Learning Development and Validation of the Colorado Learning. *Physics Education Research Conference* (pp. 442-445). Philadelphia: American Institute of Physics.
- Zwickl, B., Hirokawa, T., Finkelstein, N., & Lewandowski, H. (2013). An epistemology and expectations survey about experimental physics: Development and initial results. *arXiv*, 1310.1055.

Appendix A

Scientific Learning Community Laboratory Manual

Physics 2130
Physics for Science and Engineering Majors I

Scientific Learning Community
Student Lab Manual

Department of Physics and Astronomy
The University of Toledo
Toledo, Ohio

Physics 2130
Physics for Science and Engineering Majors I

Scientific Learning Community
Student Lab Manual

Written by Adam Lark

With help from:
Michelle Deady
Rick Irving
and Song Cheng

Using Ideas from the
Scientific Learning Community Lab
Pioneered by Joe Redish
and The University of Maryland
Physics Education Group

Department of Physics and Astronomy
The University of Toledo
Toledo, Ohio

Table of Contents

Scientific Learning Community Lab

<i>Lab Perspective</i>	5
<i>Lab Structure</i>	5
Lab Groups.....	6
Presentations.....	6
Lab Reports.....	6
Supplies.....	6
Lab Equipment Available.....	6
<i>Grading</i>	8
Session Work Points.....	8
Mid Session Homework.....	8
Lab Report Points.....	8
Participation Points.....	9
Department Grade Policy.....	9
Attendance and Extra Credit Policy.....	9
Repeating the Course.....	10
<i>Lab Policies</i>	10
Late Arrivals.....	10
Missing Lab.....	10
Missing Lab Instructor.....	11
Safety.....	11
Computer Use.....	11
Cell Phones and Laptops.....	11

Lab 1

Introduction to Kinematics

<i>Make the Case</i>	12
Reliability.....	12
<i>Session I – Construct the Case</i>	13
<i>Mid Session Homework</i>	17
<i>Session II – Presenting your Expert Opinion</i>	19

Lab 2

2 Dimensional Kinematics

<i>The Clown Cannon</i>	21
<i>Session I – Investigating Projectile Launchers</i>	22
<i>Mid Session Homework</i>	23
<i>Session II – Taking the Shots to Hit the Target</i>	25

Lab 3

<u>Force and Motion</u>	
<i>Find the Mass</i>	26
Error Bars & Statistical Error.....	26
<i>Session I – Creating the Contraption</i>	27
<i>Mid Session Homework</i>	29
<i>Session II – Running the Test to Find the Mass</i>	31
<u>Lab 4</u>	
<u>Work and Conservation of Energy</u>	
<i>Find the Height To Clear the Loop</i>	32
Systematic Error	32
<i>Session I – Testing the Track</i>	33
<i>Mid Session Homework</i>	35
<i>Session II – Running the Trials to Clear the Loop</i>	37
<u>Lab 5</u>	
<u>Conservation of Momentum</u>	
<i>Inertial Mass vs Gravitational Mass</i>	38
Repeatability.....	39
<i>Session I – Devising a System for Finding Inertial Mass</i>	40
<i>Mid Session Homework</i>	41
<i>Session II – Determining Inertial Mass</i>	43
<u>Lab 6</u>	
<u>Periodic Motion</u>	
<i>Tell the Time</i>	44
<i>Session I – Creating the Time-Telling Device</i>	45
<i>Mid Session Homework</i>	45
<i>Session II – Testing Time-Telling Device</i>	46
<i>Poster Presentation Showcase</i>	47
<u>Appendix A</u>	
<u>Error Tutorial</u>	
<i>Calculating Error</i>	48
<i>Repeatability</i>	48
Repeatability Example.....	48
<i>Statistical Error</i>	49
Statistical Error Example.....	49
<i>Systematic Error</i>	49
Systematic Error Example.....	49
<i>Incorrect Error Calculation Example</i>	50
<u>Appendix B</u>	
<u>Student Forms</u>	
<i>Group Evaluation Survey</i>	53
<i>Group Member Contact List</i>	55

Scientific Learning Community Lab

The following is the general policy for the instructional labs offered by the Department of Physics and Astronomy at the University of Toledo.

Lab Perspective

The Scientific Learning Community (SLC) Labs are designed to simulate how scientists conduct experiments in the real world. In traditional laboratories, students follow structured procedures to arrive at predetermined answers to conceptual questions. SLC labs are meant to emphasize the scientific process as opposed to getting the correct answer. In this laboratory, often the teaching assistant will not know the right answer until the end of the experiment. It is up to the students to become experts on different areas of physics and to thoroughly answer physics questions within a community of their peers. You will be expected to think and design labs with the control and attention to detail of an actual scientist. A well thought out experimental design with exceptional quality of data that accounts for error will be key to a student's success in this laboratory.

Lab Structure

Every lab will be comprised of two sessions (two weeks worth of class) and total of four hours of class time. At the end of these two weeks, it will be expected that you write a lab report on the events that transpired throughout that lab. Each lab group will consist of three to five people. Generally speaking, a typical lab will have the following components:

Lab Session I: (2 hours)

- Hand in Lab Reports from Previous Lab
- Small Discussion of the Coming Lab
- Brainstorm and Design your Experiment
- Construct and Investigate your Apparatus
- Record Pertinent Information and Take Data

Lab Session II: (2 hours)

- Reconstruct Previous Week's Setup
- Run Experiment
- Design a Short Speech of Your Work
- Present Results to the Class

Lab Groups

There will be a total of four lab groups in the class with three to five students each. Two tables in each corner are merged together to create lab groups. Lab groups are urged to get contact information from every other group member, as some group work will be needed to be done outside of class. Also, if a student must miss a day, he or she can contact their group to give them any pertinent information they may have in their possession. Teaching Assistants retain the right to, at any time, modify lab groups as he/she sees fit.

Presentations

During Session II of each lab, an hour will be set aside for group presentations. Each group presentation should be about 5-10 minutes long, and cover the design, implementation, and results of the experiment. There will be a five-minute spot at the end of each presentation for questions and discussion. Everyone will be expected to listen to each other's presentations and poke holes in other groups' procedure, just as scientific communities tend to do with their peers. This practice is not intended to be about being mean, but about doing good science and keeping everyone accountable for their work.

Lab Reports

Lab reports are due after the end of every two-week labs. They should be two to three pages long (double spaced), and are expected to arrive at the beginning of the class that follows presentations. A typical lab report should have the following sections:

1. **Introduction**- What was the major goal that you were trying to achieve or question you were trying to answer? Which part of that question did you decide to investigate?
2. **Design** – Describe the experiment that you designed to help answer this question. Be specific about why you chose these materials, how the experiment ran, and what kind of controls you had in place. Also, what equations did you utilize to arrive at the information you needed? This section generally describes events that occurred in Session I of the lab.
3. **Results** – What did your experiment tell you in terms of better answering your question or achieving your goal? What are some of the possible causes of error in your experiment? Numerically speaking, how far off is it possible that you are in your data and how does that propagate through your equations? How far off is your final answer? Estimate how far off the results of your experiment may be based on the errors in your data collection. This section is generally about things that happened during Session II as well as estimates and calculations done after the session was over.
4. **Conclusion** – Remind us of the goal or question of the lab, and how your results speak to it. How did your group fair against the other groups? What special thing (or things) did you do that made your group stand out from the other groups? Also (VERY IMPORTANT), if you were to do this experiment again, what would you change?

Supplies

Most supplies needed to perform the experiment are supplied through the class. However, items such as the lab manual, pencils, pens, paper, calculators, poster board and other incidentals are to be supplied by the student.

Lab Equipment Available

The lab is equipped with a large amount of experimental equipment which will be essential for complete labs through the semester. While not all of these pieces of equipment will be allowed in every lab, the following is a list of the equipment that may be used during a lab, the equipment's function, and possible errors that may be involved with each.

Note that this list is not meant to hinder the creative process, but to give you a sense of the items available to you. If there is something not on this list that you would like to use for your experiment, feel free to ask your teacher if it would be alright. If it makes sense, and does not cheat the intent of the lab, he or she will either find it for you, or ask you to bring it in for yourself next time.

- Meter Stick-** Basic wooden meter stick. The ability to measure to millimeter accuracy could be in question due to the bowing of the stick and visual inaccuracy.
- Duct Tape-** The staple of any lab setup. It is plentiful, and can be used to jury-rig any setup to your specific needs.
- Metal Poles and Vices-** These are very reliable supports for many experiments. The vices can clamp to the table, holding the metal poles necessary to support your experiment.
- Strings and Pulleys-** For any object in motion strings and pulleys are a must. Keep in mind that the string is not massless and a pulley will add friction to your system that must be accounted for.
- Carts-** The carts in this lab are bearing-packed and mostly frictionless. That being said, keep in mind that friction is never completely gone, and cannot be neglected.
- Projectile Launchers-** These spring-loaded launchers can hurl small balls at 3 different speeds, and are relatively consistent. Variability in the system is something worth considering, and can make the difference between a good group and a great group.
- Photo Gates & Plates-** These small black gates & plates measure the time difference between the cutting of a beam, or the depression of the plate. It can consistently measure time to millisecond accuracy. Your ability to measure the distance between the gates however leaves room for significant error using this device.
- Motion Sensor-** This small green device uses sound to accurately measure the distance to an object in front of it. Using this with the computer's Logger Pro program can yield not only distance information, but velocity and acceleration information as well. The acceleration graph is based on the slope of the velocity graph, and the velocity graph is based on the slope of the position graph, so accuracy of the first two can be questionable. Also, it can be hard to track the motion of certain objects depending on their size.
- Force Meter-** These small black boxes can measure the force (in newtons) exerted on a small hook attached to the force meter. These meters rely on a calibration process, which often results in inaccurate force information, depending on the success of the calibration.
- Scale-** The scale in the room reads the mass of an object to one gram accuracy. It is suggested that if you need to check the mass of something (even the known masses) that you use this device.
- Springs-** Springs with varying spring constants can be utilized in this lab. While their spring constant is known, due to overstretching that spring constant should be double checked for the sake of accuracy.
- Known Masses-** Masses ranging from 5 grams to 500 grams are available for use throughout the lab. Always check to make sure the mass listed is correct, as sometimes they can be off by a gram or even several grams.
- Stop Watches-** These are simple three button stop watches which can be used to measure time between events. Caution should be used when relying too heavily on the time given, as human reaction speeds can play a large role in the errors associated with this device.

Grading

A total of 192 points are available through the class, including 180 points earned through classwork and 12 points of extra credit. Each student starts with 0 points and earns his or her way up through the semester. The maximum points able to be earned are 180, which results in a 100% grade for the lab.

The 180 point total comes from two components: 150 points from in class work, and 30 points from group and class participation. The 150 points from class work comes from the 6 total labs, which are each worth 25 points. Those 25 points split further into 10 points for the lab report, 5 points for each day of the two days of lab work (10 points total), and 5 points for the mid session homework.

Point Distribution Chart

180 Points Total	150 Points Class Work	Lab 1 Introduction to Kinematics (25)	Session II Work (5) Session II Work (5) Mid Session Homework(5) Lab Report (10)
		Lab 2 Two Dimensional Kinematics (25)	Session II Work (5) Session II Work (5) Mid Session Homework(5) Lab Report (10)
		Lab 3 Force and Motion (25)	Session II Work (5) Session II Work (5) Mid Session Homework(5) Lab Report (10)
		Lab 4 Work and Conservation of Energy (25)	Session II Work (5) Session II Work (5) Mid Session Homework(5) Lab Report (10)
		Lab 5 Conservation of Momentum and Energy (25)	Session II Work (5) Session II Work (5) Mid Session Homework(5) Lab Report (10)
		Lab 6 Periodic Motion (25)	Session II Work (5) Session II Work (5) Mid Session Homework(5) Poster Presentation Showcase (10)
	30 Points Participation	Group and Class Participation (30)	Instructor's Grade (6) Student 1 Grade (8) Student 2 Grade (8) Student 3 Grade (8)

Session Work Points

By showing up on time and doing the work for each session, a student is almost guaranteed to earn their five points for that day. Only if the student is late, being disruptive or completely off task will they not earn their full five points for that day's session. Both sessions of the lab will total to 10 of the 25 points for that lab.

Mid Session Homework

At the beginning of the second session of every lab a homework worth 5 points will be due. This homework describes a physics problem that will help you complete and understand the lab at hand. If a student has been following along with his or her group the homework should take no more than 10-15 minutes to complete. If your group has finished session one early, feel free to tackle the homework problem as a group to prepare for next session.

Lab Report Points

Lab reports are worth 10 of the 25 points for a lab. Each will be graded based on the description of the Design, Results and Error Corrections of each lab group. Each grading category, described thoroughly below, can be awarded as many as 5 points.

Design:

- What was your experimental setup and why you did you choose to utilize this setup?
- What are the underlying physics principles or equations behind why you chose your setup?

- What were some of the things you controlled and varied in your experiment, and what were you hoping to find?

Results:

- Did your group describe how your experiment went and the results achieved?
- What math or physics connects your group's experiment to the results of the experiment?
- What form did your final equation (or idea) take that directly connected the experiment to the results?
- How well did your group do as compared to the other groups?
- What are some special things that your group did that made your group stand out?

Error Corrections*:

- What were some possible places that there could have been error in your experiment?
- How much did the errors affect the final results you were going for?
- How did your group account for the errors inherent in your setup?
- How many times did you run a test before you felt it sufficiently described the situation?
- What would you do differently next time, knowing what you know now?

**See Appendix A for more information on error calculation.*

The only exception to this is the lab report for the last lab: periodic motion. Instead of doing a traditional lab report, students will be expected to come to an all classes event with a poster which presents their favorite lab. In this case, the 15 points will be given for the poster presentation and not for the lab report. See "Poster Presentation Showcase" for more details.

Participation Points

Group participation is a key part of this class; for this reason it is built into the grading scheme. At the end of the semester, students will be given the chance to rate their fellow group member's performance through the semester. A total of 24 points will be given to you by your fellow group members, as well as 6 points given by your instructor. In a group of 4 students each person will be given 8 points to rate each other member, and in a group of 5 students each person will be given 6 points to rate each other member. In most situations, all points will be fully awarded. Only in circumstances where a student is regularly not helping with the lab, lab report, or presentation will points not be fully given. Be aware of this through the semester however, as your group's opinion of your participation can be the difference between a letter grade or in the worst case, passing or failing the course.

Department Grade Policy

A policy enacted by the department requires that you achieve 80% or more in the class. This means you will need to earn 144 points through the class in order to pass not only the lab, but the full 5 credit hour class. In other words, a student who does not get the requisite 144 points will not pass all of 2130!

There are two easy things one can do to make certain they pass the class:

1. Coming to class and participating with group work
2. Doing the bi-weekly lab reports

Attendance and Extra Credit Policy

Attendance is a requisite part of this lab, and is graded as such. If a class is missed a student will not only lose their 5 points for the day, but they will also lose 5 points on the lab report. Also, if either session of the two week lab is missed, no extra credit will be awarded to that student, even if their

group was awarded some for that week. This means that if a student misses one day of a lab, he or she will only be able to earn 15 out of 25 points for that week.

Repeating the Course

A student who has previously taken the course may not have to retake the lab if the following criteria are met:

1. The previous lab course was taken no more than one calendar year before the present semester
2. The lab grade received was an 80% or better (24/30 points)
3. A letter grade (A-F) was received from the lecture/quiz section of the course. If the grade received for the previous course was a withdraw (W) or an instructor withdraw (IW) then the lab must be retaken.

A student who has met each criterion should check with the lab supervisor to verify that the above requirements have been met, and then must advise his lecturer and present lab instructor- **in writing** – of this situation. This note should include your:

- Name
- Rocket Number
- Previous Lab Section and Instructor's Name
- Previous Course Section Number and Instructor's Name
- Present Lab Section Number and Instructor's Name
- Present Course Section Number and Instructor's Name

Providing this information helps ensure that credit is properly transferred. The student should confirm that appropriate credit has been given by checking with the course and lab instructor.

Lab Policies

Late Arrivals

Often times an introductory discussion will happen in the first 10 minutes of class, and is very important to what students will be doing that day. It is expected that each student will be there for the beginning of class. Anyone who is more than a minute or two late should expect a point or two to be subtracted from their grade that day.

Missing Lab

Labs may only be missed in case of sickness or emergency. Either way, an email should be sent to the lab instructor informing them of the situation. In case of sickness, it is important to get a doctor's note, and show it upon arrival to the next class. If a class is going to be missed due to job interviews, religious holiday, doctors appointments, or any other event for which a student has prior knowledge, the instructor must be informed a week ahead of time so that plans for attending another lab can be made. Failure to do so will result in loss of credit for that day's session. A session that is missed will result in a loss of 10 total points for that lab. In any case, missed homework will be due at the beginning of the next session. See **Attendance and Extra Credit Policy** for more information on the loss of points.

Missing Lab Instructor

If the lab instructor is more than five minutes late, a student should go to the lab supervisor's office (MH2020) or the main physics office (MH 2017) and ask for assistance. A substitute will be found to get the lab started.

Safety

Every effort has been made to make the experiments as safe as possible; however, several experiments are potentially dangerous if safety precautions are not followed. Because of this, students must follow all safety rules prescribed by the instructor as well as the following safety precautions, all of which are common sense:

- Wear Shoes and a Shirt to Lab
- Do Not Bring Food, Drink, or Tobacco Products to Lab
- Any Time a Projectile Launcher is in Use, Goggles Must be Worn at All Times

This lab has more freedom and decision making than a traditional lab, and therefore more responsibility for safety is expected of its students. Use your own common sense and discretion in deciding what is safe and not safe for the lab, and always defer to your lab instructor if any lab activity is the least bit questionable.

Computer Use

Computers are an integral part of education and exploration. Computer use is welcome in this lab, as getting stuck or needing information is a common occurrence. Feel free to Google, or ask Yahoo to learn more about any physics topic. Please note though, that any computer use outside of physics topics will result in this privilege being taken away from a student, or lab group.

Cell Phones and Laptops

As the labs are equipped with their own computers, looking up information on cell phones or personal laptops is not necessary. Because of their potential for distraction, no laptops or cell phone use will be permitted in lab. In the rare case that there is an application that students have available to them through their phone or laptop, but not their lab equipment, permission must be granted before using that application.

Lab 1

Introduction to Kinematics

Make the Case

In this lab, you will be introduced to kinematics as well as the style of the SLC labs. The class will be acting as the collective physics specialist team in a court case involving an accident where fault is questionable. Your group will have to construct a mathematical argument either convicting or exonerating a person of speeding. The case must be thoroughly examined, and each group must make their own conclusion. Your group needs to use not only good math, but good logic and reasoning to vouch for the side of your choosing. After discussion, all groups must agree and a unanimous verdict must be decided upon.



Lab Equipment Restriction

Normally, this will be a list of items from the equipment on page 7 that you will not be allowed to use in the lab. This lab requires no equipment, so everything is currently off limits.

Extra Materials Given

None

Useful Equations

Velocity is a change in distance over a change in time: $v = \Delta x / \Delta t$

Acceleration is a change in velocity over a change in time: $a = \Delta v / \Delta t$

Reliability

Despite what your classwork may imply, there are no exact answers in physics. No matter how hard we try, there will always be some amount of error in how things work in the real world. As all of the things we do in this lab will be firmly rooted in the real world, you will begin to appreciate that variability and error are parts of the everyday experience. When reading through the following case, try to consider what pieces of evidence are reliable or unreliable. Try to decide how much each factor could be “off” by, or whether the information is useful at all. Choosing the best evidence will lead to your group making the strongest possible argument.

Session I – Construct the Case

In this session, you will act as the physics specialists examining a highway accident. You have been hired by the county prosecutor to provide your Expert Opinion on whether Sam Jefferson was at fault for the accident. (An Expert Opinion is a legal term for the pre-prepared testimony of a professional in court.) Your group must decide which data is reliable and which data is questionable, and then construct a logical, mathematical argument supporting your Expert Opinion. Keep in mind that the other groups will be doing the same thing, with the same information, but may come to completely different conclusions. If there are any details that you may still want to know, keep in mind that your instructor may have pertinent data collected by the prosecutor from witnesses.

The Case:

Marge Richardson, a highway worker, was hit in a construction zone near the 13 mile marker along I-90 while trying to dash across the street through traffic. Her watch was stopped when she was hit at exactly 9:30:00 AM. Sam Jefferson, the man driving the car, can face up to 5 years in prison and \$40,000 in fines if convicted of speeding at **the moment he hit Marge** in the construction zone. However, if he was going the speed limit or under, he will be innocent.

The toll booth ticket for the car in question shows it entered the highway at 9:10:18 AM at exit 38. The speed limit is 70 mph, until mile marker 15, where it slows to 55mph for the construction zone. A car matching the description of Mr. Jefferson's was spotted by a police car near the 19 mile marker going approximately 77 mph on a mostly empty highway. Lastly, tire skid marks trailed for 0.056 miles directly before the accident. An accelerometer in the car recorded this skid and the moments surrounding the crash. However, the impact damaged its mounting bracket, and the accelerometer was found dangling from a cable after the accident.

Mr. Jefferson claims that he normally goes only 5 mph over the speed limit, and he is sure he wasn't speeding through the construction zone. He says he is a consistent driver who uses the cruise control as much as possible to maintain a constant speed just like most of the other cars on the highway. Point in question: was he speeding when he hit Marge?

Accelerometer Data

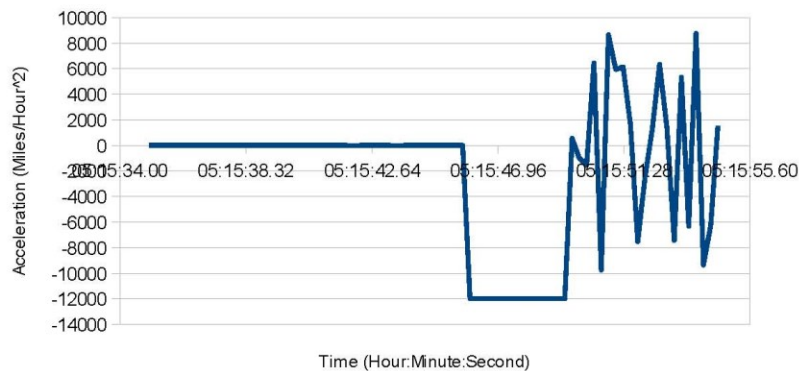

Accelerometer Data

Acceleration (miles/hour ²)	Time	Acceleration (miles/hour ²)	Time
1	05:15:35.00	1	05:15:45.00
3	05:15:35.25	2	05:15:45.25
-2	05:15:35.50	1	05:15:45.50
1	05:15:35.75	2	05:15:45.75
6	05:15:36.00	-12000	05:15:46.00
-4	05:15:36.25	-11999	05:15:46.25
5	05:15:36.50	-12000	05:15:46.50
5	05:15:36.75	-12003	05:15:46.75
4	05:15:37.00	-12004	05:15:47.00
-2	05:15:37.25	-11997	05:15:47.25
-1	05:15:37.50	-12000	05:15:47.50
0	05:15:37.75	-11998	05:15:47.75
0	05:15:38.00	-12003	05:15:48.00
-5	05:15:38.25	-12000	05:15:48.25
4	05:15:38.50	-11997	05:15:48.50
5	05:15:38.75	-11999	05:15:48.75
4	05:15:39.00	-12002	05:15:49.00
5	05:15:39.25	-11998	05:15:49.25
-3	05:15:39.50	542	05:15:49.50
4	05:15:39.75	-1000	05:15:49.75
6	05:15:40.00	-1534	05:15:50.00
4	05:15:40.25	6437	05:15:50.25
7	05:15:40.50	-9745	05:15:50.50
4	05:15:40.75	8652	05:15:50.75
3	05:15:41.00	5935	05:15:51.00
-1	05:15:41.25	6145	05:15:51.25
-1	05:15:41.50	1643	05:15:51.50
-2	05:15:41.75	-7543	05:15:51.75
-6	05:15:42.00	-2542	05:15:52.00
-1	05:15:42.25	1245	05:15:52.25
0	05:15:42.50	6345	05:15:52.50
1	05:15:42.75	1374	05:15:52.75
-1	05:15:43.00	-7438	05:15:53.00
5	05:15:43.25	5326	05:15:53.25
-8	05:15:43.50	-6324	05:15:53.50
1	05:15:43.75	8763	05:15:53.75
4	05:15:44.00	-9372	05:15:54.00
-3	05:15:44.25	-6253	05:15:54.25
-4	05:15:44.50	1523	05:15:54.50
-3	05:15:44.75		

Guiding Questions

After reading through the case, what is your initial reaction: (circle one)

Sam is at Fault

Sam is Not at Fault

Why?

List the pieces of data that your group feels are reliable.

List the pieces of data that your group may use in your Expert Opinion, but don't feel as confident about.

List the pieces of data that you will likely throw out, and why you may throw them out.

Using basic math and physics, how did this situation play out on paper? (eg. Sam was going 90mph from mile 38 to mile 13, where he slowed down to 50 before he hit Marge)

At the end of session 1, what conclusions did you come to: (circle one)

Sam is at Fault

Sam is Not at Fault

Why?

Mid Session Homework

Name: _____

Describe the events leading up to the crash. How fast was Sam going during each leg of the journey? How fast was he going the moment he hit Marge? How do you know this? Use both math and physics to justify this description of the events.

What conclusion does this lead you to: (circle one)

Sam is at Fault

Sam is Not at Fault

19

Session II – Presenting your Expert Opinion

In this session, each group will present its Expert Opinion to the other groups and come to a consensus. Groups will have 20 minutes to review their work from last week, and make changes based on any new physics they may have learned through a week of class. Each group will present their Expert Opinion to the class as a whole, making use of your whiteboards. Use the space below to take note of each groups' arguments as they discuss them. After each presentation, groups will have the opportunity to ask questions and make comments. Keep in mind that everyone will have to come to the same conclusion by the end of the class, so listen carefully to find the things you agree and disagree with.

After presentations, individual members will be allowed to visit other groups, ask questions, and dig deeper into their analysis. Your group may have to include new information in your Expert Opinion to make the most accurate possible argument. When your group begins to agree with another group, feel free to write a brief summary of your Expert Opinion on the class whiteboard for the class to see. As this happens, other groups can discuss and edit the whiteboard as they see fit. When every group agrees with the Expert Opinion on the class whiteboard, you will be allowed to leave for the day. Remember to take sufficient notes as your Expert Opinion must be written into a 2 or 3 page lab report, due the next week of lab.

Group ___ notes:

Group ___ notes:

Group ___ notes:

Final Class Answer:

Lab 2

2 Dimensional Kinematics

The Clown Cannon

In this lab, we will be experiencing projectile motion first hand as our class will be working as the research and development team of a circus supply company. Many circuses have asked for a safe and reliable way to do the “shoot the clown out of the cannon” trick. Your company’s machine shop has developed a small scale mockup of the final product. The mockup includes a projectile launcher simulating the clown cannon, and a target representing the netting. Your job is to test and troubleshoot this projectile launcher to prepare for a coming demonstration. The ringleader of a renowned circus will be visiting your company, so all projectile launcher must be able to hit a target on the first shot without incident. If all goes well, the circus will sign a contract with your company and everyone on the team will receive a nice bonus; equivalent to 2 bonus points in class. Your group will have an opportunity to investigate your projectile launcher and determine its specifications before the day of shooting. On the day of shooting, each group will have only one shot to impress the ringleader and win the contract for your company.

Lab Equipment Restriction

None

Extra Materials

Projectile Launcher
Photo Paper

Useful Equations

3 Kinematics Equations:

$$v = a * t + v_0$$

$$x = x_0 + v_0 * t + \frac{1}{2} a * t^2$$

$$v^2 = v_0^2 + 2 * a * (x - x_0)$$

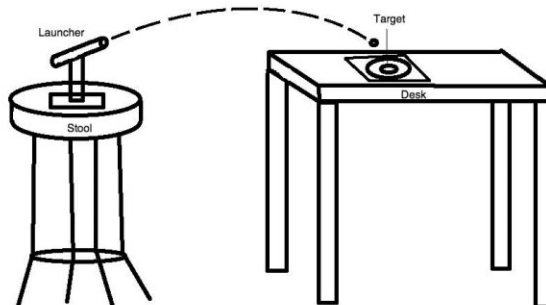

Projectile Launcher

There are three settings, each corresponding to a different initial velocity which your group can use to shoot your projectiles. You will hear your projectile launcher click every time you increase the velocity setting. For this experiment, please only use the second click setting for your launches.

Session I – Investigating Projectile Launchers

In this session, your group will have the chance to experiment with your projectile launcher and determine its properties. Take as much time as your group needs to test your launcher, and figure out the math and physics required to determine the initial velocity of your projectile launcher. In session II the launcher will be fixed to a stool which will be taped to the ground. Your instructor will fix the angle of the launcher and your group will have to position the target on the desk to make sure it is hit on the first shot. Through the coming week, keep this in mind as you will have to solve this two dimensional kinematics problem by next class.

Guiding Questions

What equation can you use to find the initial velocity of the projectile as it leaves the launcher?

Which values in the above equation do you know or can you measure?

What value in the above equation will you have to test your launcher to obtain?

Based on the tests and calculations, what is the initial velocity of your projectile?

$$V_0 = \text{_____ m/s}$$

How many times should you test your launcher (shooting the exact same shot) to confirm this value?

Number of tests = _____
(If you haven't already, make sure to take and record all of this data)

What was the highest initial velocity possible based on this data? _____ m/s

What was the lowest initial velocity possible based on this data? _____ m/s

Based on the highest and lowest, what is the error in your velocity?

Plus or Minus: _____ m/s

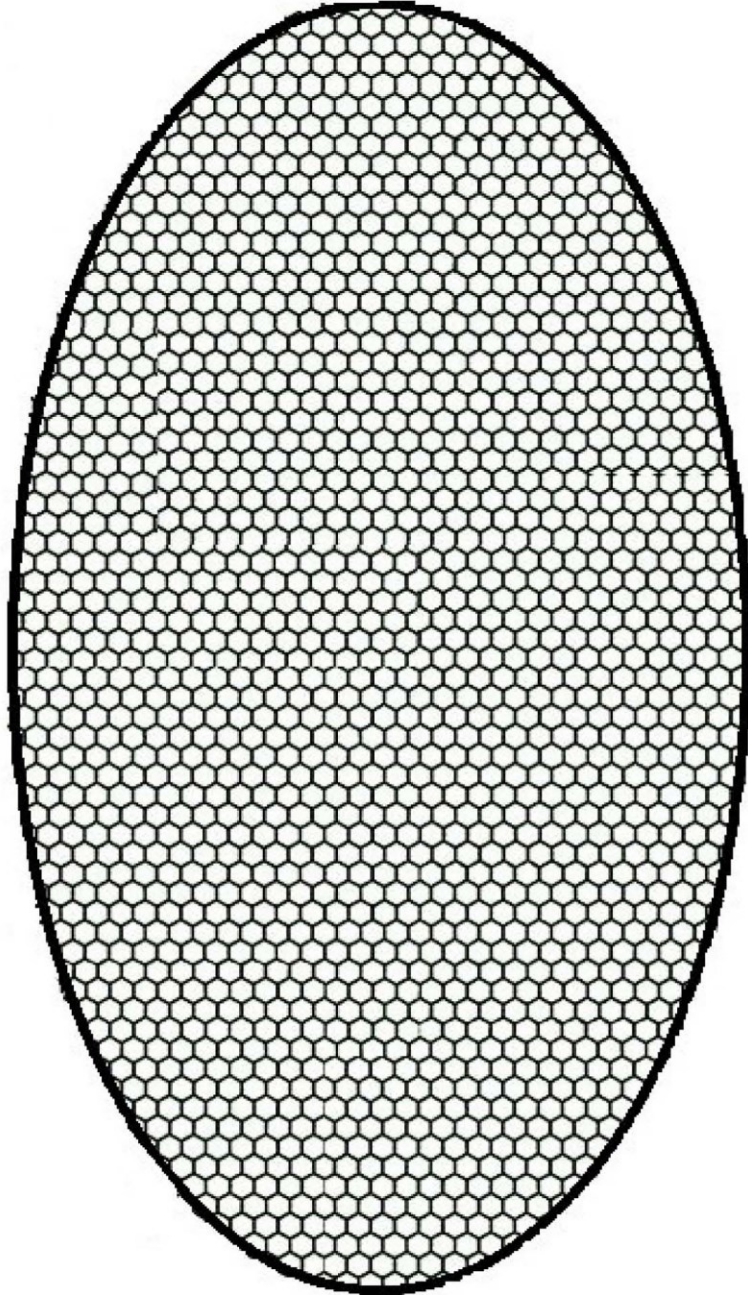

25

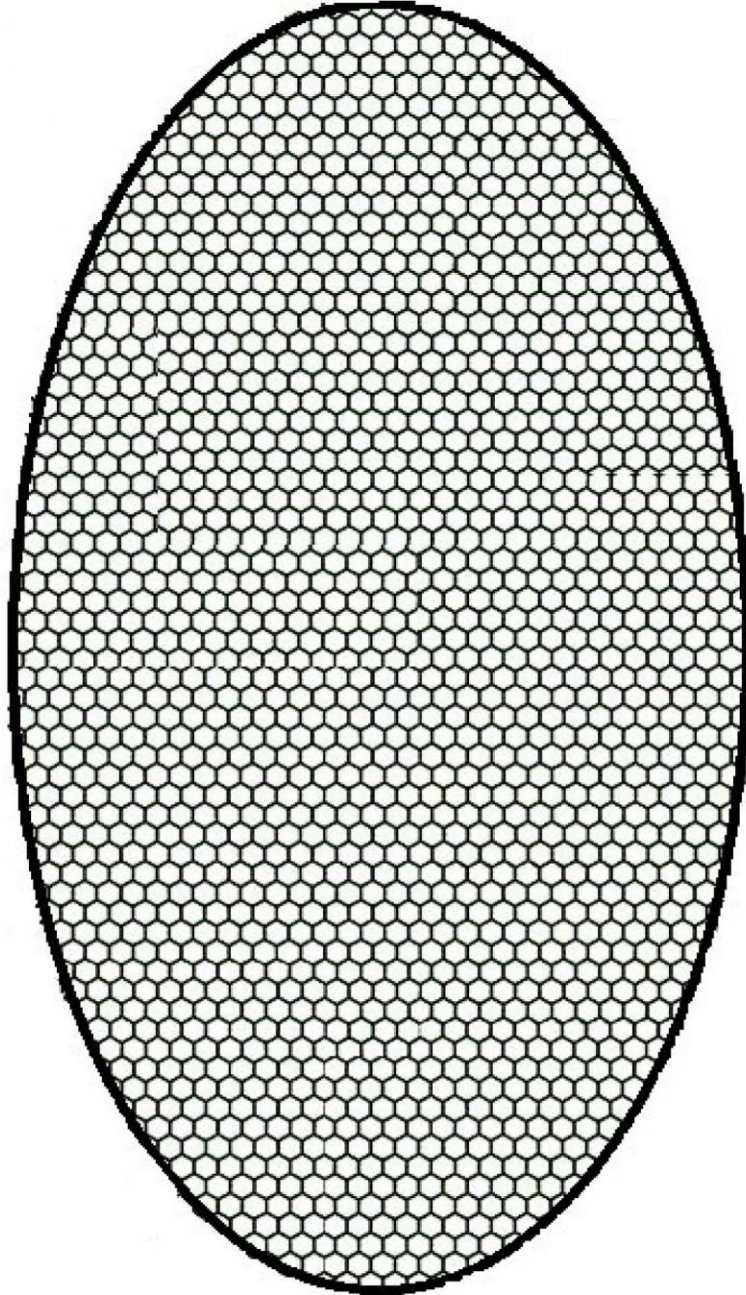

Mid Session Homework

Name: _____

Between sessions, it is important to get some physics under your belt, so that you will be prepared for our next class. Throughout the week, you may learn about these topics in lecture, or you may have possibly covered them already. Either way, please attempt the problems below, as it will be pertinent to session II of this lab.

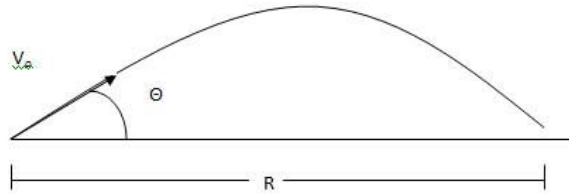

1. A projectile is shot from the ground at an angle of 40 degrees with an initial velocity of 10 m/s. It lands on the ground at a distance R away from the launch location.
 - A. Split the initial velocity into the x and y component.

$$V_{0x} = \text{_____} \text{ m/s} \quad V_{0y} = \text{_____} \text{ m/s}$$

- B. How long will the projectile be in the air (Hint: look only at the Y direction)?

- C. Find R , the distance the projectile will travel? (Hint: look only at the X direction)?

Session II – Taking the Shots to Hit the Target

During this session your group will be expected to hit a target on the first attempt. Take some time with your group to discuss the homework solution and make sure everyone came to similar results.

Guiding Questions

What equation(s) will you need to predict the distance your projectile will fly?

Which values in the above equation(s) do you know or can you measure?

Test A Shot - There should now be enough information to take a practice shot. Set the angle on your launcher, run the calculations, set the target distance and attempt a test shot. If it doesn't hit the target on the first try, don't despair. Your group has 30 minutes to reevaluate the measurements, recalculate the initial velocity, and try additional shots to calibrate your system. Make sure to take multiples of the same shot to confirm that all possible shots will hit the target.

Guiding Questions

After numerous attempts at the same shot, make a circle around the landing sites on your sheet encompassing all of the points. Now measure the distance from the center to the edge. What is the distance of this spread?

Is this distance smaller or larger than the bounds of the target?

This variability in distance can be considered the *statistical error* of your system. If you have time, can your group connect the variability in your initial velocity to the variability in the distance the ball can travel? See Appendix A for more information on error bars and error calculation.

Set Up For The Final Shot - The ringleader will now fix the angle setting on each launcher. The class will be given 20-30 minutes to take whatever measurements, and run whatever math needed to accurately place your target on the desk. During this time **no practice shots are allowed**. Tape the target on the desk where you expect the ball to land and **do not shoot** until all groups are ready! Each group will present their shot to the class and to the ring leader. If all group successfully hit the target the contract will be rewarded and everyone will receive 2 bonus points for the day.

Lab 3

Force and Motion

Find the Mass

In this lab your group will eventually be given a paper bag filled with an unknown amount of candy that will have to be tested to determine number of candies in the container. It is up to your group to devise a system for determining the mass of an object based on its inertial properties. Groups will have the opportunity to design a device that will measure mass, and will be given a chance to put that device to the test. Not only will groups have to determine the number of candies they received, but they will also will have to decide on the possible error bars of their system. If the number of candies is within their error bars the class will be allowed to partake in the candies.

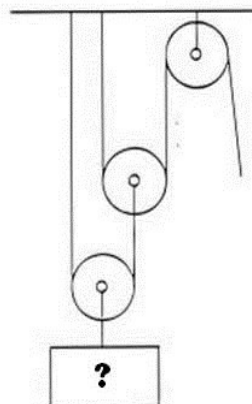

Lab Equipment Restriction

Force Meters

Springs

Known Masses (Session II)

Mass Scale (Session II)

Extra Materials Given

Metal Track, Cart, Pulleys, and String

Useful Equations

Net Force: $F_{net} = M * a = \text{Sum of all the forces}$

Error Bars & Statistical Error

Error bars will tell a group just how far their experiment could possibly be off from their calculated answer. In this lab, it is very possibly that your contraption will not be the most precise system, often giving different results for the same test. It is important to take note of how questionable the measurements are, so that you can gauge how far off your mass calculation may be. See Appendix A for more information on statistical error, error bars and error calculation.

Session I – Creating the Contraption

In this session your group will design and test your contraptions. The goal is to be able to be given an unknown mass and (using your contraption) determine the mass of the unknown object. Your group will be given access to all masses and mass reading-devices during this session, however next session you will be limited to only a 50g, 100g, and 500g known mass.

Guiding Questions / Brainstorming

Individually, try to think about a *force and motion* physics problem that you may have solved in class, or seen in your physics book. Alternatively, you can grab some equipment and start designing a contraption, or log on to the internet for some inspiration. Once you have found a problem you are interested in, ask yourself the following questions:

Can you create this situation using only the materials given in class?

Can you remove any elements to simplify the problem?

How many things would you need to know to fully describe this system?

Can you either fix or determine all but one of the parameters of this system?

Draw a picture of the contraption below and share it with your group.

Decide which idea your group would like to attempt based on if it seems the least complicated, most reliable, easiest to execute, or even most interesting. Draw a diagram of the contraption your group has decided upon on the group whiteboard and run it past your instructor. Once cleared by your instructor, create the system and start testing it!

You may have to do some math and physics to be able to run calculations for your system. If it helps, your group should start on the homework for the following session as it guides you through this process. Run your system and the equations to see if what your group has come up with is giving numbers in the vicinity of the correct answer.

Mid Session Homework

Name: _____

Draw a picture of the system that you created in this week's session.

Draw a free body diagram of each of the masses in the diagram. Place an arrow representing every force acting on each mass.

Create a Net Force statement ($F_{\text{net}} = ma$) for each mass in the diagram.

Solve the equation(s) to create a single equation and solve it for your unknown mass.

Equation for Unknown Mass: $M =$

33

Session II – Running the Test to Find the Mass

In the previous session, your group devised a system for determining the mass of an object. For this session, your group will be testing this system for accuracy and reliability. Your group will be given an hour to setup and recalibrate your system. During this time, all devices and masses are allowed to be used. Your group must do multiple trials with known masses to find both the offset (how far off your system is consistently off from the correct answer) and the error bars of the system.

After the first hour, all mass measuring devices are off limits for the remainder of this session, and only one 50g mass, one 100g mass, one 500g mass, and the 50g hooked platform will be available for use. Groups will be given 30 minutes to determine the mass of a bag of candies. This number will translate into the number of candies in your bag. After groups have determined the number of candies as well as the error bars, presentations will be run, and the weigh-ins will occur. The instructor will check the mass of each unknown mass and compare it with the mass and error bars given by your group. If the mass is within the error bars, your group will earn that bag of candy.

Guiding Questions

Of all of the measurements taken, what is the median value, and the highest and lowest value?

Median Value = _____

Lowest Value = _____

Highest Value = _____

Using these values, calculate the median, lowest, and highest mass of your groups unknown mass.

Median Mass = _____

Lowest Mass = _____

Highest Mass = _____

Using the mass, calculate the median, lowest, and highest number of candies possible in your bag.

Median # of candies = _____

Lowest # of candies = _____

Highest # of candies = _____

When testing, was your mass calculation incorrect by a similar amount every time? If so how much systematic error is there in your mass calculation? How many candies will this translate to?

What is the cause of this systematic error?

Lab 4

Work and Conservation of Energy

Find the Height To Clear the Loop

In this lab, our class will get to see conservation of energy in motion, as we work as a roller coaster track testers. The machine shop has worked out a small scale version of the roller coaster called "The Threshold" which is going into mass production in the coming year. The roller coaster is meant to start from rest at the top of a hill, roll down and just barely make it over the loop at the bottom. While it is easy to work out the details using physics equations, the

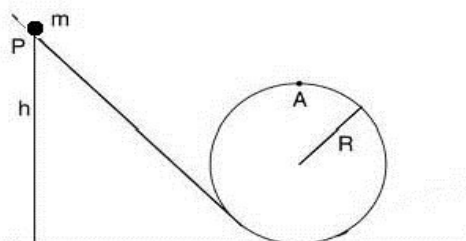

machine shop is well aware that the answer you get won't clear the coaster through the loop. The track needs to be tested for possible issues and the true lowest possible release height must be found.

Your group will be given a ball which will eventually be rolled down the track in the center of the class room. The goal is to find the minimum height to release the ball from in order to fully complete the loop so that on full scale launch day the coaster will make it over the loop on the first try.

Extra Materials Given

5 lengths of test track (note: you may not bend these track pieces into a loop)

Metal Ball

Useful Equations

Conservation of Energy: $E(\text{initial})=E(\text{final})$

Work: $W = F * d$ (where the friction and air resistance hides)

Potential Energy: $U = m * g * h$

Kinetic Energy: $K = \frac{1}{2} m * v^2$

Systematic Error

No matter how tuned a system is, sometimes it is impossible to get the correct answer using textbook physics. The answer may be off by a significant amount every time due to something that you may have not accounted for in your original equation. This is called systematic error. It is important to not only identify the source(s) of systematic error, but try to quantitatively determine their effect on your system. This can be done by putting an extra term to the main equation, adding an offset for this error.

Session I – Testing the Track

In this session, your group will begin work towards finding the release height of the ball. The ball will be expected to be released from the lowest possible height in order to successfully clear the loop and hit the block at the end of the track. To find this, your group will have to work through the applicable physics equations on paper, and then find the error through experimentation. The track in the center of the class is the track that all metal balls will be launched from, and is off limits for all testing this session. You may however take as many measurements of the track that you wish. The meter stick beside the track will determine the release point of your metal ball for the lab instructor.

To start, consider the physics problem posed in your mid-session homework. This will frame the problem mathematically, and set up the ideas that you will have to experiment with this session.

Guiding Questions / Brainstorming

What is the big equation that you need to find the release height of the ball? Make sure to add a term for the loss throughout the motion, as it will be very important to determining the correct height.

What are the known (or easily measured) quantities in your big equation(s)?

What quantity in your big equation will you need to design an experiment in order to calculate?

Draw a diagram of the experimental setup you used to figure out the height above.

Mid Session Homework

Name: _____

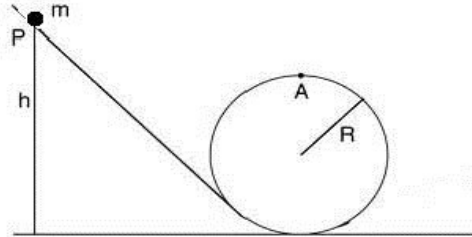

1. A ball, initially at rest, is launched from an unknown initial height (h), rolls down a ramp into a loop of radius $R=5$ m. The ball clears the top of the loop (point A) at the lowest possible velocity.

A. What kind(s) of energy does the ball have at the top of the ramp?

B. What kind(s) of energy does the ball have at the top of the loop?

C. What is the velocity at the top of the loop? (Hint: It is not zero! Use centripetal force ideas to determine the speed.)

D. Create a Conservation of Energy statement by setting part A = part B.

E. Solve the Conservation of Energy statement (from D) to find the minimum initial height the ball should be released to barely make it over the loop.

$$H = \text{_____ m}$$

F. How would you add a "loss" term to the conservation of energy equation to account for possible frictions in the system?

Mid Session Homework

Name: _____

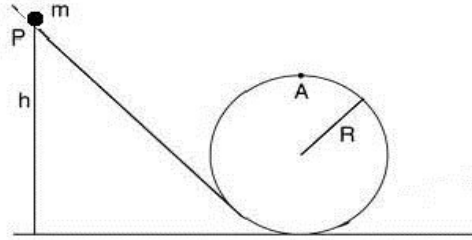

1. A ball, initially at rest, is launched from an unknown initial height (h), rolls down a ramp into a loop of radius $R=5$ m. The ball clears the top of the loop (point A) at the lowest possible velocity.

A. What kind(s) of energy does the ball have at the top of the ramp?

B. What kind(s) of energy does the ball have at the top of the loop?

C. What is the velocity at the top of the loop? (Hint: It is not zero! Use centripetal force ideas to determine the speed.)

D. Create a Conservation of Energy statement by setting part A = part B.

E. Solve the Conservation of Energy statement (from D) to find the minimum initial height the ball should be released to barely make it over the loop.

$$H = \text{_____ m}$$

F. How would you add a "loss" term to the conservation of energy equation to account for possible frictions in the system?

Mid Session Homework

Name: _____

Draw a diagram of the system your group created **before** the collision. Include arrows representing velocity of any cart.

What is the equation for the initial momentum of the cart?

Draw a diagram of the system your group created **after** the collision. Include arrows representing velocity of any cart.

What is the equation for the final momentum of the system?

Did the total momentum of the system change from the initial point to the final point? If so what caused that change in momentum?

Create a conservation of momentum equation that describes your system fully.

Solve this equation for the unknown inertial mass:

$M =$

45

Session II – Running the Trials to Clear the Loop

Groups will be given an hour to remind themselves of their work from last week and finalize their answer for the release height. At the end of the hour, all groups must submit their release height **measured from the meter stick at the side of the track**. Each group will present their experiment to the class followed directly with the instructor running the trial for the measurement given. Keep in mind that the edge of the ball will be launched from the measurement indicated on the meter stick next to the track.

Guiding Questions

What is the full equation that determines the release height of the ball?

What was the setup you used to fill in the blanks of that equation?

Was there a velocity at the top of the loop?

How did your group account for friction and air resistance?

How did your group account for the systematic error in the system?

Lab 5

Conservation of Momentum

Inertial Mass vs Gravitational Mass

In physics, mass has two widely different explanations: gravitational and inertial. Inertial mass describes an object's resistance to acceleration; more massive objects resist motion more than less massive objects. In contrast, gravitational inertia describes the strength with which gravity pulls on an object. It is our job to test those two kinds of mass and determine if they have the same value. If inertial mass is the same as gravitational mass (within the error bars of our experiment) we can conclude that they are equal. If gravitational mass is outside the error bars of our experiment, we can conclude they have different values.



To measure the gravitational mass of the object, we can easily place the object on a scale. To make this a blind study, however, we will be restricting our use of scales until the end of the lab and using an unknown mass for our tests.

Previously, our class created elaborate systems utilizing pulleys, strings and moving masses to find the inertial mass of an object. Now, with a much larger physics arsenal, we can revisit this question using a much less complex concept: *conservation of momentum*. By tracking changes in motion, we can determine the inertial mass of an object. Your group's task is to utilize carts and a track to create a system where momentum can be reliably determined and the inertial mass of an object can be found.

Materials Given

Carts (with known mass)
Force Probes
Motion Detectors
Known Masses

Useful Equations

Conservation of Momentum: $P(\text{initial})=P(\text{final})$

Momentum: $P = m * v$

Change in momentum: $\Delta p = J = \int F dt$

Repeatability

One trial is good, two trials is better. When there are unpredictable errors causing differing amounts of loss in a system, many trials may be needed to get the most reliable information possible. Taking precise measurements and tracking error does wonders for cleaning up results, but if the results are changing drastically between measurements, the system can't be relied on for any valid results. Always take as much data as possible and look for consistencies in that data. If similar results can be achieved repeatedly, one can be sure that the system is performing reliably.

Session I – Devising a System for Finding Inertial Mass

This session your group will be tasked with creating an experiment that will determine the inertial mass of an object. You will be expected to use some combination of carts, track, motion sensors and force sensors to create a situation that can be described using the concepts and mathematics of conservation of momentum.

Guiding Questions / Brainstorming

Individually, consider many of the classic problems of *conservation of momentum* that can be recreated using carts and a track. Once you have found a problem you are interested in, ask yourself the following questions:

Can you create this situation using only the materials given in class?

Can you remove any elements to simplify the problem?

How many things would you need to know to fully describe this system?

Can you either fix or determine all but one of the parameters of this system?

Draw a picture of the contraption below and share it with your group.

Decide which idea your group would like to attempt based on if it seems the least complicated, most reliable, easiest to execute, or even most interesting. Draw a diagram of the contraption your group has decided upon on the group whiteboard and run it past your instructor. Once cleared by your instructor, create the system and start testing it!

You may have to do some math and physics to be able to run calculations for your system. If it helps, your group should start on the homework for the following session as it guides you through this process. Run your system and the equations to see if what your group has come up with is giving numbers in the vicinity of the correct answer.

Session II – Determining Inertial Mass

In the previous session, your group devised a system for determining the inertial mass of an object using conservation of momentum. For this session, your group will be testing this system for accuracy and reliability. Your group will be given an hour to setup and recalibrate your system. Run a sufficient amount of trials to make sure all systematic and statistical error has been accounted for. It is not only important to get an answer for the inertial mass of the object, but understand the range of possible masses you are likely to get. When your group feels confident that its experiment is running properly and, ask, and your instructor will give your groups its unknown mass.

After groups have determined the inertial mass of their object and the potential error bars of their experiment, presentations will be run. The instructor will test the gravitational mass of the object by using the class scale and compare it with the inertial mass and error bars given by each group. If all of the unknown mass is within the error bars, it is safe to consider inertial and gravitational mass equivalent. If the masses are all outside the error bars, they will be considered not equivalent. If groups get different answers, a discussion will have to occur to decide which groups had the most reliable experiment, and whose answer to trust.

Guiding Questions

How many trials did your group run to determine the inertial mass of the object?

Of all of the measurements taken, what is the median value, and the highest and lowest value?

Median Value = _____

Lowest Value = _____

Highest Value = _____

Using these values, calculate the median, lowest, and highest inertial mass of the object.

Median Mass = _____

Lowest Mass = _____

Highest Mass = _____

When testing, was your mass calculation incorrect by a similar amount every time? If so how much systematic error is there in your mass calculation?

Based on this information, estimate the inertial mass and the error bars of your system.

Inertial Mass = _____

Error Bars = \pm _____

Lab 6

Periodic Motion

Tell the Time

Precisely telling time has been a problem that has been around for many millennia. Before digital devices, numerous methods have been employed with differing levels of success and accuracy. The task for this lab throw our hat into this historic ring and create a time telling device using only the materials in the class. To test your group's contraption, we will be removing all watches, clocks, and digital devices from the room. Your group will run its time telling device for 1 to 5 minutes, and have to identify how much time has passed with as much accuracy as your device will allow. The group who can get the closest to determining the time on the instructor's stopwatch will earn 10 bonus points.

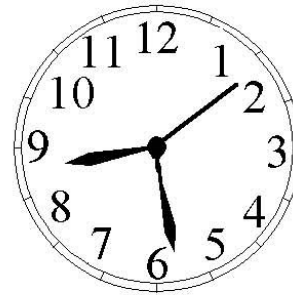

Lab Equipment Restriction

Stopwatches (Session II)
Clock (Session II)
Computer (Session II)
Wristwatches (Session II)
Cell Phones (always)

Extra Materials Given

Just ask! If you come up with a good idea your instructor may be able to find the material to execute it.

All Lab Section Challenge

In this lab, groups will not only be competing with groups in class, but all groups throughout every lab. Due to this, precision and creativity is a necessity for the coveted first prize. Lab results will not be revealed until the day of the showcase.

Lab Report and Homework Reminder

There is no lab report or homework due for this lab. In exchange, there will be a poster session the last week of class worth 15 points which all students will be required to attend.

Session I – Creating the Time-Telling Device

Prepare to deploy all of the creativity, precision, error accounting, and procedural knowledge gained through the semester in the creation and testing of a device that can tell time. The accuracy of this device must be to the second, and it must run with this accuracy for anywhere between 1 minute and 5 minutes. Remember, if there are materials that your group wishes to use, ask your instructor and he or she may be able to produce these materials. This session you will have the ability to use stopwatches, computers and clocks, which you will need to calibrate your device. Next session however, all of these devices will not be allowed, so use them now.

Guiding Questions

Draw a diagram of your device, complete with any details of your system.

How precise is the device? To the second? To the millisecond?

How is your group's device able to accurately last as long as 5 minutes?

What are some possible causes of error in your group's system and how does your group plan on compensating for this error?

Mid Session Homework

Work on your poster presentation! The 5 homework points for this week will be gained from your poster presentation, making it worth a total of 15 points.

Session II – Testing Time-Telling Device

In this session groups will be running their device against the instructor's stopwatch to see which group can get the closest to the correct time. Groups will be given 20 minutes to get their device setup and calibrated before the trials begin. During this 20 minutes, groups are allowed to use stopwatches and the computer to help recalibrate their systems. After this, the class will be instructed to put away all watches, cell phones, computer, or any other devices that could potentially tell time. Three trials each ranging from 1 to 5 minutes will be performed. The goal will be to determine how long each of those trials lasted using your time-telling device. The winner will be the group (of all 2130 labs) that gets closest to the instructor's mark added over all three trials. That group will win 10 points and the bragging rights of being the most accurate group in all of 2130. The results will be revealed during the poster presentation showcase, described on the following page.

Questions to Consider for your Presentation

Describe your device in good detail, including any creative modification enacted.

How accurate is your group's device in short 1-2 minutes runs?

How accurate is your group's device in long 3-5 minute runs?

What did your group do to account for the difference in accuracy between shorter runs and longer runs?

What did your group do differently that makes your techniques or device stand out from the other groups?

Notes for lab Report

Trial 1	Trial 2	Trial 3
_____ Minutes	_____ Minutes	_____ Minutes
_____ Seconds	_____ Seconds	_____ Seconds

Poster Presentation Showcase

The final week of class there will be an all class event to wrap up the semester. In lieu of doing homework and a lab report for periodic motion, student will be expected to come to a Showcase day bearing a poster presentation. This poster will be regarding your group's favorite lab, the lab you feel you showed the most creativity, or the lab you feel you did the the best on. Every group member should be versed in your group's presentation, as only half of your group will be doing the presentation. The other half of your group will be wandering around and checking out other posters presented by your fellow class mates. There are many ways to accomplish the tasks in the labs from this semester. This is a chance to show everyone your creative techniques for completing these labs, as well as get to see other great ideas and innovations from the semester.

There will be 40 minutes of mingling and poster presentations followed by the announcement of the winners of the Timing Lab.

Appendix A
Error Tutorial

Calculating Error

This tutorial describes how a student properly identifies and calculates error in their lab setup. This also is an excellent reference for writing the *Error Corrections* portion of the lab report. Keep in mind that by error, we do not mean “how far off you were from the correct answer”. There are ways to estimate the reliability of your experiment based on the answers you get, this is what you should start to think of as error.

Repeatability

“A man with one watch knows what time it is. A man with two watches is never quite certain.”

Before discussing error, it is important to distinguish between the physics problems done in lecture and the physics problems done in this lab. In class, every problem is tailored to be as pristine as possible. Massless, frictionless, perfectly spherical objects often lead to one perfect solutions to in class physics problems.

Unfortunately, the real world is far messier than these problems would lead you to believe. This leads to many fluctuations and uncertainties in your system. This means that almost never will you get the same exact answer twice. In lab, the only way to be truly certain of your results is to run the same test multiple times to prove that you are getting consistent results surrounding a certain answer. The more trials done the better you can hone in on that answer. Always do as many trials as possible to confirm your results.

Repeatability Example

Students in a lab group shot a ball once across the room, measured the distance and used that information to calculate the velocity of the ball coming out of the barrel of the launcher. From that measurement the group knew exactly what angle they needed to shoot the ball to hit any target at any distance. The day of the test, the target was set on the ground, the angle was calculated and the shot was taken. To the group’s horror, the ball was two centimeters short of the center of the target. After class the students, trying to figure out what had happened, shot the ball 20 times at the target. In most of their tests, the ball was the same 2 centimeters off from the target as their in-class shot. The ball hit the center once, and hit the edge of the target once as well. As it turns out, the single shot they took was an outlier, when the bulk of the shots generally fell around 2 cm short of the target. By taking multiple shots they were able to see the data mostly clumped around 2 cm short of the target.

Statistical Error

Statistical error refers to the random fluctuations that occur when doing the same test over and over again. Even while doing the same trial in the same exact way, different results are likely to occur. After numerous trials, the number of occurrences of each of these results can be plotted to form a bell curve. By looking at this spread of data not only can one find the most likely solution, you can calculate how far it is possible the answer is off from that central point. This technique can aid in the creation of error bars as not only is the most likely answer known, but how far off that it is possible that answer is off from the

Statistical Error Example

A baker producing bread listed as twenty ounces per loaf has difficulty making each loaf such that it weights precisely twenty ounces. Some loaves can be heavier by as much as 2 ounces and some might be lighter by 2 ounces. If loaves sold customers average twenty ounces in weight, on a given day one family might get less bread for their money than another family, but after enough loaves a family's bread will average out to 20 ounces per loaf. After a few complaints however, the baker decided to put error bars of plus or minus 2 ounces on every 20 ounce label.

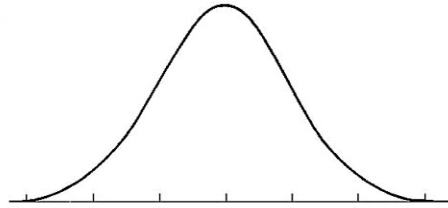

Systematic Error

Systematic error is symptomatic of something going consistently wrong every time you try to make a measurement. It could mean that every time you measure using a certain scale that the weight is consistently off by 20 lbs, or every time you check your watch it is off by 5 minutes. If a value is consistently off by a certain amount, it is likely there is an error systematically propagating itself through your math and your experiment. Systematic error it should first be identified and then reduced as best as possible. The less systematic error the more accurate the experiment. When it is impossible to fully rid yourself of systematic error, compensate for it by offsetting you answer to correct for the error.

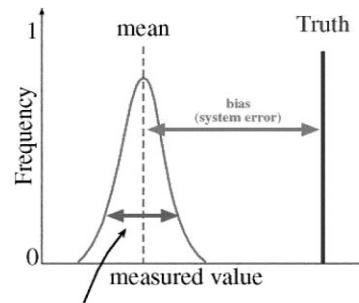

Systematic Error Example

After doing the math for the fifth time, the students were getting frustrated. Attempting to find the mass of an unknown object, they had designed a system to test the acceleration of a set of moving masses. The measurements for their system had been checked seven times and were giving very consistent results. The force-body diagram was pristine, and the net-force statement gave the exact answer for the unknown mass. No matter what they did, the result was consistently off by 35 grams. One of the students mentioned that the pulley in their system could have been adding friction to the system, and the air resistance of the moving masses could be slowing the motion. While this was a great idea, the students didn't know how to measure the coefficient of friction, or the force of air resistance. They decided that, as long as the system remains the same, they could predict that any test would result in an error of 35 grams. They decided that simply adding 35 grams to any answer would be sufficient to get the correct mass.

Incorrect Error Calculation Example

A group shot their projectile launcher at a set angle 3 times and was short of their target by 4 cm, 3 cm and 5 cm. In their lab report it was stated that: "Our group shot the ball and it was an average of 4 cm off from the target, therefore our error is 4 cm." When answering the question about where their error had come from they stated that "it was human error, which made our group off by 4 cm."

This error assessment is wrong for 3 large reasons:

1. Error is not associated with how far off a group was from their goal. It is largely a result of smaller factors that compound themselves resulting in the discrepancy between the calculation and the results. It is likely that this group was off on their velocity calculation due to their inability to measure distance accurate to the millimeter. When plugging the velocity discrepancies into the equation, the group found that the possible range of target values could be off by as much as +2 cm or -2 cm.
2. There are two different kinds of error that are possible. In this case it is likely that there was both statistical error and systematic error resulting in this group's poor targeting. While in the previous point, statistical error was discussed, there was a significant systematic error that the group had yet to account for. The group was an average of 4 cm off, which means that there was a problem somewhere in their system that resulted in the math not matching reality. It is likely that air resistance played a key role in making the ball fall 4 cm short consistently.
3. There is no such thing as human error. Error is something that has a tangible cause, and should always be properly identified (mathematically if possible). In this case, what this group meant by human error was a difficulty in reading a meter stick down to millimeter accuracy. A better way of expressing that would be to say "our group was not able to read the meter stick to millimeter accuracy, making it possible that the measurement was off by plus or minus 1 millimeter."

Appendix B

Student Forms

Name _____

Group Evaluation Survey

Lab Time _____ Lab Day: M T W R F

How would you describe the role you play in your group?

Member #1 Name: _____

How constructive or helpful has this person been to the group activity?

Not Helpful 1 2 3 4 5 Very Helpful

Additional Comments?

Member #2 Name: _____

How constructive or helpful has this person been to the group activity?

Not Helpful 1 2 3 4 5 Very Helpful

Additional Comments?

Member #3 Name: _____

How constructive or helpful has this person been to the group activity?

Not Helpful 1 2 3 4 5 Very Helpful

Additional Comments?

Member #4 Name: _____

How constructive or helpful has this person been to the group activity?

Not Helpful 1 2 3 4 5 Very Helpful

Additional Comments?

Member #5 Name: _____

How constructive or helpful has this person been to the group activity?

Not Helpful 1 2 3 4 5 Very Helpful

Additional Comments?

Member #6 Name: _____

How constructive or helpful has this person been to the group activity?

Not Helpful 1 2 3 4 5 Very Helpful

Additional Comments?

Do you have any thoughts or concerns about your group dynamic as a whole?

Group Member Contact List

Name: _____

Email: _____

Phone Number: _____

Name: _____

Email: _____

Phone Number: _____

Name: _____

Email: _____

Phone Number: _____

Name: _____

Email: _____

Phone Number: _____

Name: _____

Email: _____

Phone Number: _____

Appendix B

Demographic Survey

The Following is a demographic survey for students enrolled in Physics 2070. Please circle your answer or write a short sentence for each question as appropriate. **All questions are optional.**

Name: _____

Lecture Instructor: Uma Vijn Naresh Sen

Laboratory Day: M T W R F

Laboratory time: _____ AM / PM

1. What is your gender?
 - a. Male
 - b. Female

Appendix C

Uncertainty Interview 1

After failing to hit a single ball at the batting cages, you feel very embarrassed and decide not to bat again until you are sure you can hit the ball. You decide the best way to do this is to study the batting machine by measuring the height the ball crosses the plate and using that data to practice your swing. After setting up a measuring tape against the wall and mounting a camera, you take a picture as the ball crosses the plate and measure the height.

Q1. Upon looking at your picture, you measure the height of the ball to be 81 cm off the ground. How valid would you consider this height?

Q2. If you were to take a swing, at this point what height would you aim your bat?

Q3. Is it possible for the height of that swing to be off from the actual height of the ball? What could have caused that inaccuracy? How would those details change the height the ball crosses the plate?

Q4. Without taking a swing, how would you confirm the height you measured?

Q5. After taking 27 successful pictures, you record the height and put them in a table in order from highest to lowest. What do you notice about these numbers?

Q6. Why are the height measurements different even though it is the same machine pitching over and over again?

Q7. Using these numbers, how would you find the ideal height to swing the bat? Would you average all of the numbers? What about the first and last data points? Why would you use an average?

Q8. If the ball was pitched, how far off is it possible that this number (from the previous question) is from the height of the pitched ball? Would you still pick the number from the previous question? Why?

Q9. With this number in hand, you set up a practice ball at [their height] at home, and practice swinging until you can consistently swing at this height. Now feeling prepared, you go to the batting cages, step up to the machine you have been testing and swing at [their height] at the first ball pitched to you. Unfortunately, you miss low by what you estimate to be 20 cm, meaning the ball actually came in at [height of 20+their height]. Is this number consistent with your data? What would you conclude based on this?

Q10. Feeling frustrated, you swing again, and miss by around 20 cm this time, a height of about 105 cm. What would you conclude based on this?

Q11. You swing for one final time, and are off by around 20 cm again (height of 105 cm). What would you conclude based on this?

Q12. After feeling embarrassed for the last time you flee the cages. A week passes, and you decide to try one more time to hit the ball. Going back to the same cage, you notice your camera and measuring tape are still where you left them, although they have swapped the pitching machine with a different model. Using your current camera and meter stick setup (which is in the same position as a week ago), how would you design a test that will be sure to get you the correct height? Be as specific as possible, and list all the step you would take to achieve the most accurate number for height.

Appendix D

Written Interview 1

After failing to hit a single ball at the batting cages, you feel very embarrassed and decide not to bat again until you are sure you can hit the ball. You decide the best way to do this is to study the batting machine by measuring the height the ball crosses the plate and using that data to practice your swing. After setting up a measuring tape against the wall and mounting a camera, you take a picture as the ball crosses the plate and measure the height.

1. Upon looking at your picture, you measure the height of the ball to be 81 cm off the ground. How valid would you consider this height? (circle one)

Completely Invalid – Moderately Invalid – Moderately Valid – Completely Valid

2. If you were to take a swing, at this point what height would you aim your bat?

3. Is it possible for the height of that swing to be off from the actual height of the ball? (circle one)

No - Maybe - Yes

4. If yes, or maybe: What could have caused that inaccuracy? How would each of those things change the height the ball crosses the plate?

5. Without taking a swing, how would you confirm the height you measured?

You decide to take many pictures to confirm your results. After 27 successful pictures, you record the heights and put them in a table in order from highest to lowest.

Height (cm)
105
91
90
89
89
88
88
88
87
87
87
87
87
86
86
86
86
85
85
84
84
83
83
82
82
81
80
79
64

6. What do you notice about these numbers?

7. Why are the height measurements different even though it is the same machine pitching over and over again?

8. Using these numbers, how would you find the ideal height to swing the bat? What makes you choose that method?

9. Using the method you described in question 8, find the ideal height that you would swing the bat.

H = _____ cm

10. If the ball was pitched, how far off is it possible that the number from question 9 is from the height of the pitched ball?

11. Would you still pick the number from question 9? Why?

With the height from question 9 in hand, you set up a practice ball at home, and practice swinging until you can consistently swing a bat at this height. Now feeling prepared, you go to the batting cages and step up to the machine that you have been testing. You swing using your practiced height from question 9 at the first ball pitched to you. Unfortunately, your swing is too low by what you estimate to be 20 cm.

12. Is this number consistent with your data? (circle one)

Yes - No

13. What would you conclude based on this?

14. Feeling frustrated, you swing again, and miss by around 20 cm again. What would you conclude based on this?

15. You swing for one final time, and are off by around 20 cm again. What would you conclude based on this?

After feeling embarrassed for the last time you flee the cages. A week passes, and you decide to try one more time to hit the ball. Going back to the same cage, you notice your camera and measuring tape are still where you left them, although they have swapped the pitching machine with a different model.

16. Using your current camera and meter stick setup (which is in the same position as a week ago), how would you design a test that will be sure to get you the correct height? Be as specific as possible, and list all the step you would take to achieve the most accurate number for height.

Appendix E

Uncertainty Interview 2

Q1. You shoot the projectile launcher once and your friend who is holding the meter stick measures the height to be 94 cm. Using your formula, you calculate the velocity of the projectile launcher to be 4.29 m/s. How valid is your answer?

Q2. If I asked you what the velocity of the projectile launcher was, what would you tell me?

Q3. Could this number be off from the initial velocity of the projectile launcher? What could have caused this inaccuracy? How would that effect the initial velocity?

Q4. How would you validate this number?

Q5. You shoot the projectile 23 times total to make sure. (give them the data table) The results have been arranged in the given table in order of lowest to highest height. What do you notice about these numbers?

Q6. Why do we get a different measurement for height and velocity even when we are shooting the same shot over and over again?

Q7. Using these numbers, how would you find the initial velocity of the projectile launcher? Take an average of all the number? What about the first and last data points? Why would average be used?

Q8. How far off is it possible that this number (from the previous question) is off from the initial velocity of the projectile launcher? Would you still pick the number from the previous question? Why?

Q9. Feeling certain of your initial velocity, you decide to take a shot at the target on the desk (see diagram below for details). You set the launcher to 45 degrees and use your initial velocity and the range equation $[R = (v_o^2/g) * \sin^2(2\theta)]$ to calculate the distance the projectile will travel. [write down their initial velocity. mean: 180 cm; median: 178 cm; mode: 176 cm] The target is placed at this distance and the projectile is shot. To your horror, the projectile travels short of the target with a total distance of 84 cm. Is this answer consistent with your data? What would you conclude based on this?

Q10. Feeling frustrated, you shoot again, and the projectile falls short again with a total distance of 86 cm. What would you conclude based on this?

Q11. You shoot one final time, and the projectile is short again with a total distance of 81 cm. What would you conclude based on this?

Q12. You are given a new launcher (with a different initial velocity) and another chance to hit the target. At this point, there isn't enough time to reinvent a new method. You use the same equations and don't change anything about the system you used to find your initial velocity or distance to the target. Describe in detail what steps under these conditions to be sure to hit the target this time? Be specific and list every step you would take to hit the target.

Q13. What about your general experience brought you to the answers on this survey?

Q14. Were there any aspects of your laboratory experience that brought you to these answers?

Q15. Were there any aspects of your laboratory experience that made you think differently about how science is conducted?

Appendix F

Written Interview 2

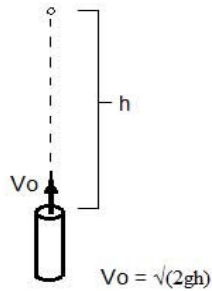

As part of a “hit the target” competition you must find the initial velocity of a projectile launcher. To do this, you decide to shoot the projectile straight up into the air and measure the height of peak of the projectile’s flight using a meter stick. With this height, you can use the (correct) equation $v_0 = \sqrt{2gh}$ to calculate the initial velocity of the projectile.

1. You shoot the projectile launcher once and your friend who is holding the meter stick measures the height to be 94 cm. Using the formula $v_0 = \sqrt{2gh}$, you calculate the velocity of the projectile launcher to be 4.29 m/s. How valid is your answer? (circle one)

Completely Invalid – Moderately Invalid – Moderately Valid – Completely Valid

2. If I asked you what the velocity of the projectile launcher was, what would you tell me?

3. Could this number be off from the initial velocity of the projectile launcher? (circle one)

No - Maybe - Yes

4. If yes, or maybe: What could have caused this inaccuracy? How would each of those things effect the initial velocity?

5. How would you validate the initial velocity from question 2?

	Height of Flight (cm)	Initial Velocity of Launcher (m/s)	
You shoot the projectile 23 times total to make sure. The results have been arranged in the given table in order of lowest to highest height.	42	2.87	
	85	4.08	
	86	4.11	
	86	4.11	
	87	4.13	
	87	4.13	
	88	4.15	
	88	4.15	
	88	4.15	
	88	4.15	
	6. What do you notice about these numbers?	89	4.18
		89	4.18
		90	4.20
		91	4.22
		92	4.25
		93	4.27
		94	4.29
		95	4.32
		96	4.34
		97	4.36
		98	4.38
		99	4.40
	195	6.18	

8. Using these number, how would you find the initial velocity of the projectile launcher? What makes you choose that method?

9. Using the method you described in question 8, find the most correct possible initial velocity.

$V_0 = \underline{\hspace{2cm}} \text{ m/s}$

10. How far off is it possible that this initial velocity (from question 9) is off from the actual initial velocity of the projectile launcher?

11. Would you still pick the number from the previous question? Why?

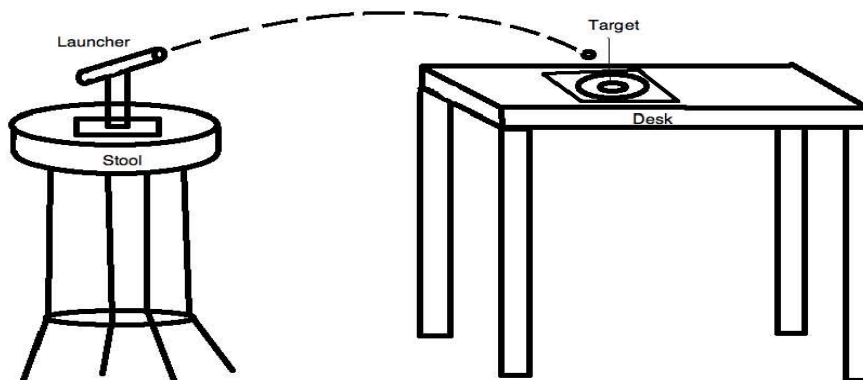

Feeling certain of your initial velocity, you decide to take a shot at the target on the desk (see the diagram above for details). You set the launcher to 45 degrees and use your initial velocity and the range equation $[D = (v_0^2/g) \sin^2(2\theta)]$ to calculate the distance the projectile will travel. Below is a chart of all of the possible initial velocities of the launcher, and the distance the projectile will travel based on those velocities.

12. Using the chart and your initial velocity from question 9, find the distance the projectile will travel.

D = _____ m

The target is placed at the distance from question 12 and the projectile is shot. To your horror, the projectile travels short of the target with a total distance of 84 cm.

13. Is this answer consistent with your data?

Yes - No

14. What would you conclude based on this?

<u>Initial Velocity of Launcher (m/s)</u>	<u>Distance Projectile Will Travel When Shot at 45 degrees based on initial velocity(cm)</u>
2.87	84
4.08	170
4.11	172
4.11	172
4.13	174
4.13	174
4.15	176
4.15	176
4.15	176
4.15	176
4.18	178
4.18	178
4.20	180
4.22	182
4.25	184
4.27	186
4.29	188
4.32	190
4.34	192
4.36	194
4.38	196
4.40	198
6.18	390

15. Feeling frustrated, you shoot again, and the projectile falls short again with a total distance of 85 cm. What would you conclude based on this?

16. You shoot one final time, and the projectile is short again with a total distance of 82 cm. What would you conclude based on this?

Q10. You are given a new launcher (with a different initial velocity) and another chance to hit the target. At this point, there isn't enough time to reinvent a new method. You use the same equations and don't change anything about the system you used to find your initial velocity or distance to the target. Describe in detail what steps under these conditions to be sure to hit the target this time? Be specific and list every step you would take to hit the target.

Appendix G

Uncertainty Interview 3

To determine the mass of an object you have developed the contraption seen here. You hang the object with the unknown mass from the pulley and let the cart accelerate down the track. You record an acceleration with this motion sensor and use that number in the (correct) equation: $m_{\text{unknown}} = M_{\text{cart}}a/(g-a)$ to determine the mass of the unknown object.

Q1. You run a test and get an acceleration of 1.36 m/s^2 . Using your formula, you calculate the mass of the unknown mass to be 158 grams. How valid is your answer?

Q2. If I asked you what the mass of the unknown mass what would you tell me?

Q3. Is it possible that this number is off from the mass of the object? What could have caused this inaccuracy? What would that do to the mass?

Q4. How would you validate this number?

Q5. Without changing anything about the setup, you run the same test 20 times total.

(give them the data table) The results have been arranged in the given table in order of highest to lowest mass. What do you notice about these numbers?

Q6. Why do we get a different measurement for mass and acceleration even when we are doing the same test over and over again?

Q7. Using these number, how would you find the mass of the unknown mass? Take an average of all the number? What about the first and last data points? Why would average be used?

Q8. How far off is it possible that this number (from the previous question) is from the mass of the object? Would you still pick the number from the previous question? Why?

Q9. You measure the mass with a scale, it ends up being 287 grams. Is this answer consistent with your data? What would you conclude based on this? What was wrong with it? What could have caused this error? How would you deal with this offset?

Q10. You are given an new unknown mass. Not changing anything about your contraption or equations and without weighing it, how would you test this new unknown mass? Be specific and list every step you would take to achieve the correct mass.

Q11. What about your general experience brought you to the answers on this survey?

Q12. Were there any aspects of your laboratory experience that brought you to these answers?

Q13. Were there any aspects of your laboratory experience that made you think differently about how science is conducted?