

ANATOMY AND EVOLUTION OF MORTON SUBOTNICK'S *IN TWO WORLDS*
FOR ALTO SAXOPHONE AND INTERACTIVE COMPUTER

Jeffrey A. Heisler

A Document

Submitted to the Graduate College of Bowling Green
State University in partial fulfillment of the requirements
for the degree of

DOCTOR OF MUSICAL ARTS

May 2010

Committee:

John Sampen, Advisor

Ronald Shields,
Graduate Faculty Representative

Mark Bunce

Jacqueline Leclair

Kenneth Thompson

© Copyright by Jeffrey A. Heisler, 2010
All Rights Reserved

ABSTRACT

John Sampen, Advisor

In 1987, Morton Subotnick completed his groundbreaking composition *In Two Worlds*. This pioneering work was a milestone for interactive computer music with its early use of the Yamaha WX7 Wind Controller, the electronic Air Drum, and Subotnick's unique orchestration featuring solo alto saxophone, wind controller, full orchestra, and interactive computer. As a result, *In Two Worlds* contributed to rapid advancements in computer technology during the late 20th century as our contemporary society grew to anticipate and expect constant technological change. The instability in this environment spawned many innovations as well as rapid turnover in technology, thus forcing Subotnick to create several revisions of *In Two Worlds* between 1987 and 1992. Since the mid-1990s, the original hardware, software, and operating systems have become obsolete and unavailable; consequently, *In Two Worlds* has not been actively performed for the past decade.

This study seeks to consider the following problems: 1) Should Subotnick's *In Two Worlds* be preserved for future performers? 2) If so, should one replicate the exact electronic parameters used in the original work, thus producing a time capsule from 1987? 3) Should performers expect continuous updates of the interactive computer patch for *In Two Worlds* as technology advances in the future? 4) Is there a correct or preferred version of Subotnick's multiple revisions of this work? 5) Finally, what biographical events led Subotnick to the creation of *In Two Worlds* and what cultural and technological environments influenced his development?

This research will consider the evolution of performance, technology, and musical meaning in Morton Subotnick's *In Two Worlds* by examining its conception, structural revisions, and changes in technology and orchestration. With the consent of the composer, the author and Mark Bunce¹ have re-created a new version of the composition by updating and replicating the interactive computer patch to *Max/MSP*, thus making *In Two Worlds* performable again. This research will also address the problems of re-constructing past electronic works for performance with modern technology as well as proposing rationale behind the extensive revisions of *In Two Worlds*. Most importantly, this project will prepare the work for a new life in the saxophone repertoire by re-introducing *In Two Worlds* to saxophonists for performance with modern interactive computer technology.

¹ Mark Bunce is the sound engineer for the Mid-American Center for Contemporary Music at Bowling Green State University. He worked with John Sampen during the premiere of *In Two Worlds* and produced the first commercially available recording (Neuma Records 1992). In addition, he was instrumental in creating the updated *Max/MSP* patch for *In Two Worlds*.

ACKNOWLEDGEMENTS

There are many people who have contributed to this project and deserve recognition for their assistance. First, I wish to express my sincere gratitude and appreciation to Dr. John Sampen for the patience, guidance, inspiration, motivation, and encouragement he shared with this writer and performer over the past six years. I am forever grateful for his generosity and will always value the artistic stimulation I received while under his tutelage. Additionally, I am especially grateful to Mark Bunce for his technological expertise and collaboration during the initial research for this project.

I would also like to express my appreciation to Morton Subotnick for his willingness to share experiences and personal antidotes to help support and validate my research. In addition, special thanks to Susan Fancher, Kenneth Radnofsky, and James Forger for their valuable assistance in this project.

This document would not have been possible without the efforts of Dr. Marilyn Shrude, Dean Richard Kennell, and the administration of the Bowling Green State University College of Musical Arts in their creation of the Doctor of Musical Arts in Contemporary Music degree program. I also extend a special thank you to Dr. Kenneth Thompson, Dr. Jacqueline Leclair, and Dr. Ronald Shields for serving on my doctoral examining committee. All of these mentors have contributed greatly to this document.

I also wish to acknowledge Dr. Bruce Moss and Dr. Carol Hayward for their guidance and mentorship during my service as a conducting graduate assistant in the BGSU Band Department.

Most importantly, I appreciate the patience, support, and inspiration of my wife, Megan, and the rest of my family and friends for their encouragement during this research and my continued academic career.

TABLE OF CONTENTS

	Page
INTRODUCTION	1
CHAPTER I. MORTON SUBOTNICK BIOGRAPHY	4
1.1: Education and Employment	4
1.2: Compositional Activity and Significance	10
CHAPTER II. HISTORY AND SIGNIFICANCE OF <i>IN TWO WORLDS</i>	14
2.1: The Commission	14
2.2: Technology	20
2.3: Premieres and Problems	29
2.4: The <i>Max/MSP</i> Patch	40
CHAPTER III. ANATOMY AND EVOLUTION	50
3.1: Anatomy of <i>In Two Worlds</i>	50
3.2: Evolution of <i>In Two Worlds</i>	63
CONCLUSION	73
APPENDIX A. INTERVIEW WITH MORTON SUBOTNICK	76
APPENDIX B. LETTERS AND PHOTOS.....	88
REFERENCES	98

LIST OF FIGURES/TABLES

Figure/Table	Page
1 Buchla 100 Modular Synthesizer	6
2 Subotnick, Zaliouk, and Sampen (1987 Toledo Symphony Premiere)	17
3 Interactive Live Processing Effects (<i>In Two Worlds - Interactor</i>)	23
4 Yamaha WX7 Wind Controller Pamphlet	25
5 John Sampen Demonstrates a WX7 Wind Controller	27
6 World Premieres of Different Versions of Subotnick's <i>In Two Worlds</i>	29
7 World Premiere of <i>In Two Worlds</i> (Toledo Symphony 1987)	30
8 Electric Symphony Poster (London 1988)	32
9 Electric Symphony Orchestra Program (London 1988)	33
10 New Mexico Symphony Performance Program (1988)	34
11 First Performance of Solo Alto Saxophone and Computer Version of <i>In Two Worlds</i> (1990)	36
12 Pesaro, Italy Performance of <i>In Two Worlds</i> (1992)	37
13 Susan Fancher Performance at UNCG New Music Festival (2007)	39
14 Sound Event Gate Object (<i>In Two Worlds</i> - 2007)	41
15 Reverb Object (<i>In Two Worlds</i> - 2007)	42
16 Delay Object (<i>In Two Worlds</i> - 2007)	43
17 Pitch Shifter Object (<i>In Two Worlds</i> - 2007)	44
18 Sound Event Gate Object with Delay Triggers (<i>In Two Worlds</i> - 2007)	45
19 Home Screen of Max/MSP Version of <i>In Two Worlds</i> (2007)	46
20 <i>In Two Worlds</i> Effects Processing Chart	47

21	Original Formal Sections of <i>In Two Worlds</i>	52
22	Musical Characteristics of <i>In Two Worlds</i>	53
23	<i>In Two Worlds: Alone</i>	54
24	<i>In Two Worlds: Rushing</i>	55
25	<i>In Two Worlds: Celebration</i>	56
26	<i>In Two Worlds: Lullaby</i>	57
27	<i>In Two Worlds: Cadenza</i>	58
28	<i>In Two Worlds: John Sampen's Suggestions for Cadenza 2</i>	59
29	<i>In Two Worlds: Combat Dance</i>	60
30	<i>In Two Worlds: Combat Dance with "Celebration" Rhythmic Motive</i>	61
31	Revisions of <i>In Two Worlds</i> (1987–2007)	63
32	Fax: John Sampen's Suggestions to Solo Saxophone Part (1990)	91-95
34	E-mail to Susan Fancher from Jeff Heisler Regarding Dynamics in <i>In Two Worlds</i> . ..	96
35	E-mail to Subotnick from Jeff Heisler Regarding 2007 Revision	97

PREFACE

In Two Worlds by Morton Subotnick is a groundbreaking work for alto saxophone and interactive computer, marking one of the first compositions to integrate the saxophone, orchestra and interactive computer. This pioneering composition is significant for its innovation and implementation of music technologies such as the computer software *Interactor*, the Yamaha WX7 Wind Controller, and the Air Drum. The evolution of *In Two Worlds* is fascinating, suggesting a need for a chronological history of its creation, revision, and resurrection.

Morton Subotnick is acknowledged today as a pioneering composer, performer, inventor, music educator, and philosopher; however, his innovations in music have been rarely discussed in scholarly writing. This is extraordinary considering Subotnick's recognition by *Newsweek* magazine as "the first sonic virtuoso."² This document will serve as primary original research on his electronic music innovations and his historical impact on the saxophone.

² Susan Fancher, "Program Notes for "In Two Worlds," *innova records*, <http://www.innova.mu/notes/736.htm> (accessed September 24, 2009).

ANATOMY AND EVOLUTION OF MORTON SUBOTNICK'S *IN TWO WORLDS* FOR ALTO SAXOPHONE AND INTERACTIVE COMPUTER

INTRODUCTION

Morton Subotnick's saxophone concerto *In Two Worlds* was at the forefront of music technology in the late 20th century during an age of constant technological innovation. Subotnick used the commission of *In Two Worlds* as a personal research project to create, synthesize, and refine the technological skills he developed in the 1980s. *In Two Worlds* soon became a repository for recent electronic experiments by Subotnick and other pioneering engineers. The evolution of this composition is fascinating, suggesting a chronological history of its creation, revision, and resurrection.

Morton Subotnick is recognized today as a pioneering composer, performer, inventor, music educator, and philosopher; however, his innovations in music have been rarely discussed in scholarly writing. This is surprising considering Subotnick's recognition by Newsweek magazine as "the first sonic virtuoso."³

Composed in 1987, *In Two Worlds* was commissioned by saxophonists John Sampen (Bowling Green State University), Kenneth Radnofsky (New England Conservatory of Music), and James Forger (Michigan State University) with a 1984 National Endowment for the Arts Grant of \$18,000 to be used for the commissioning of new music for the saxophone.⁴ Other compositions resulting from this consortium were

³ Susan Fancher, "Program notes for "In Two Worlds"," *innova records*, <http://www.innova.mu/notes/736.htm> (accessed September 24, 2009).

⁴ Susan McDonald, "Sampen to introduce New Saxophone," *Monitor: Bowling Green State University*, January 11, 1988.

Donald Martino's *Concerto* for Alto Saxophone and Chamber Orchestra and Milton Babbitt's *Whirled Series* for Alto Saxophone and Piano.⁵

The National Endowment for the Arts was particularly generous to the saxophone in 1984 when it awarded two major grants for the commissioning of new works. Besides the Sampen / Radnofsky / Forger consortium, a second NEA project featured saxophonists Donald Sinta, Laura Hunter, and Joseph Wytko with commissions of William Albright's *Sonata*, William Bolcom's *Lilith*, and David Diamond's *Sonata*.⁶ Of these pieces, only Subotnick's composition required electronic technology. These two NEA consortiums of 1984 ultimately produced music for the saxophone that became core works in the repertoire.

In 1987, Morton Subotnick's groundbreaking work *In Two Worlds* was at the forefront of interactive computer experimentation. However, the required equipment and software quickly became obsolete as rapid advancements replaced Subotnick's operating systems. Ultimately, *In Two Worlds* has evolved into multiple versions ranging from a thirty-five minute concerto for saxophone and orchestra with interactive computer to an orchestration including Yamaha's WX7 Wind Controller to a final adaptation solely for saxophone and interactive computer. As each version was created, the technology was reduced and reconfigured to facilitate more successful live performances.

This document will discuss the problem of interactive computer technology and its implementation into live performance by using Morton Subotnick's *In Two Worlds* as a study of how early interactive computer music has become obsolete and how modern

⁵ Susan McDonald, "Sampen to introduce New Saxophone," *Monitor: Bowling Green State University*, January 11, 1988.

⁶ Kirk O'Riordan, "William Albright's *Sonata for Alto Saxophone and Piano: A Study in Sylistic Contast*" (ASU, August 2003).

interactive computer technology such as *Max/MSP* can be used to resurrect these works with more reliability. In addition, the author will examine technological innovations of *In Two Worlds* along with its historical sequence of re-orchestrations. Lastly, this document will discuss the reconstruction of *In Two Worlds* and its reintroduction into the saxophone repertoire.

CHAPTER I. BIOGRAPHY OF MORTON SUBOTNICK

1.1: EDUCATION AND EMPLOYMENT

Morton Subotnick was born in Los Angeles, California on April 14, 1933. By the age of thirteen, he was already enamored with the music of Charles Ives, Bela Bartok, and Arnold Schoenberg, which inspired his interest in composition. During his last year of high school (1951), Subotnick was writing acoustic twelve-tone music in the style of Anton Webern. By 1957, however, he had recognized the enormous potential of the emerging medium of electronic music.

Prior to his life as a composer, Subotnick explored other professional pathways. After high school, he attended the University of Southern California for one semester as an English major. At the same time, he pursued a performance career as a clarinetist and in February of 1952, he won a clarinet position with the Denver Symphony Orchestra.⁷

While in Colorado, Subotnick earned his undergraduate degree in English Literature from the University of Denver. In 1954, shortly after the conclusion of the Korean War, Subotnick was drafted into the United States Army and was stationed in San Francisco, California. Here he began private lessons in composition with Leon Kirchner.⁸ In 1957, Subotnick accepted a fellowship to pursue his Master's degree in Composition at Mills College in Oakland, California where he studied with the famous French composer, Darius Milhaud.⁹ While at Mills College, he continued his professional performing career as a clarinetist in the San Francisco Symphony Orchestra.

⁷ Morton Subotnick, interview by Jeff Heisler, *Phone Interview* (as paraphrased by author), (September 21, 2009).

⁸ Ibid

⁹ Ibid

He also founded the Mills College Chamber Players, an ensemble consisting of Nate Rubin, violin; Bonnie Hampton, cello; Naomi Sparrow, piano; and Morton Subotnick, clarinet.¹⁰

As a graduate student, Mr. Subotnick recalls that he was “already set in his compositional ways.”¹¹ His teachers, Leon Kirchner and Darius Milhaud, had “no influence on me in terms of compositional style.”¹² However, Subotnick notes that, “both Kirchner and Milhaud had a great influence on my career by focusing my efforts primarily on composition and less on the clarinet.”¹³ By 1961, Subotnick had chosen his career path, sacrificing his prominent clarinet performance career to pursue composition and electronic music. When speaking about this decision, Subotnick explains,

I didn’t enjoy being a clarinetist. It came too easy for me—I played the Debussy *Rhapsodie* with major orchestras at the age of sixteen and won a job with the Denver Symphony at eighteen. Plus I really didn’t like playing in public, it was not agreeable to me. So, I saw a lot of potential in the electronic medium and was ready for a ‘real challenge.’ I thought that being a studio artist was the direction for me—that way I can be everything from creator to performer.¹⁴

After graduation from Mills College in 1961, Morton Subotnick received noteworthy compositional recognition as an invited speaker at the Princeton Seminars in Advanced Musical Studies.¹⁵ Also in 1961, Subotnick was appointed to the faculty of Mills College where he and his colleague Ramon Sender co-founded the San Francisco Tape Music Center.¹⁶ While in San Francisco, Subotnick also served as music director of

¹⁰ Morton Subotnick, *Silver Apples of the Moon*, Program Notes, 1967.

¹¹ Morton Subotnick, interview by Jeff Heisler, *Phone Interview* (as paraphrased by author), (September 21, 2009).

¹² Ibid

¹³ Ibid

¹⁴ Ibid

¹⁵ Ibid

¹⁶ Morton Subotnick, *Silver Apples of the Moon*, Program Notes, 1967.

the Ann Halprin Dance Company and the San Francisco Actor's Workshop. It was during this period that Subotnick collaborated with Donald Buchla in developing one of the first analog synthesizers, the Buchla modular synthesizer (see Figure 1), which is now located in the Smithsonian Museum.¹⁷

Figure 1: Buchla 100 Modular Synthesizer¹⁸

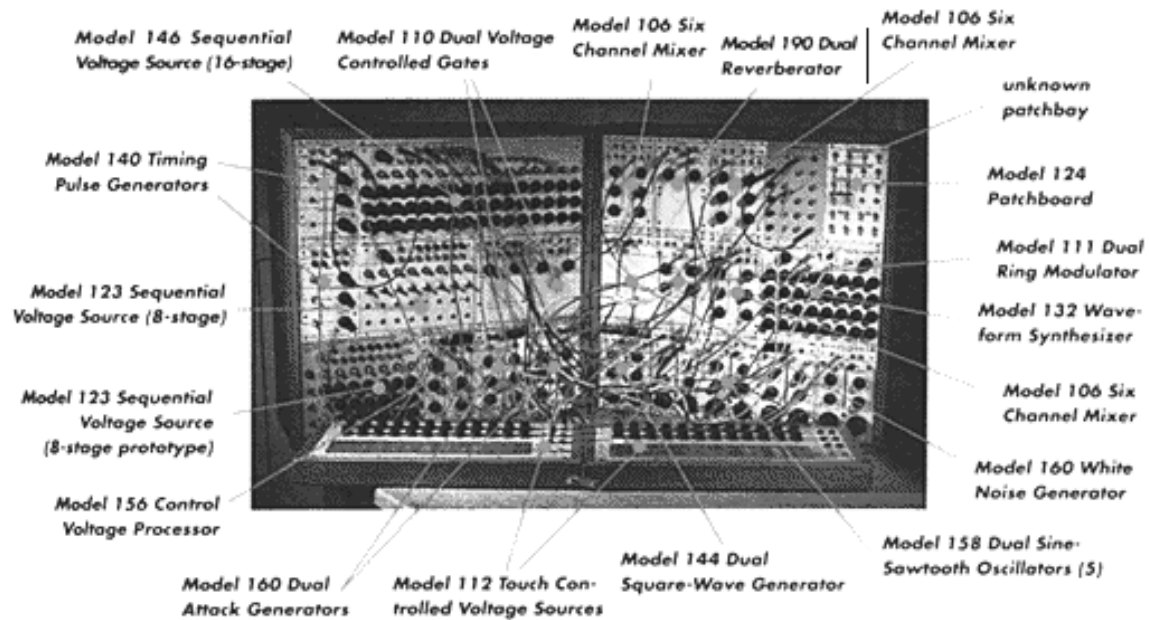

In 1966, Subotnick was instrumental in securing \$200,000 from the Rockefeller Foundation to merge the San Francisco Tape Center with the Mills Chamber Players. The grant required the relocation of the San Francisco Tape Center to the host institution of Mills College where Subotnick continued to serve on the faculty. Before the merger, however, Subotnick left Mills College for a position in New York City as the first music

¹⁷ Morton Subotnick, "Biography," *Morton Subotnick Biography*, <http://www.mortonsubotnick.com/about.html> (accessed December 15, 2008).

¹⁸ Each Buchla 100 modular synthesizer was made to order and configured differently with any number of modules.

director of the Lincoln Center Repertoire Company in the Vivian Beaumont Theater at Lincoln Center.¹⁹ He also became an artist-in-residence at the newly formed Tisch School of the Arts at New York University where he was supplied with a studio (located on Bleecker Street in New York City) and a Buchla Synthesizer. Here Subotnick began work on his landmark electronic composition *Silver Apples of the Moon*.²⁰

In 1969, Subotnick was invited by the Disney Corporation to join a team of Los Angeles based artists in planning a new school for the arts.²¹ Subotnick, and fellow committee members, Bernard Rands and Roger Reynolds, carved out a new path for music education and created the now famous California Institute of the Arts.²² Subotnick served as Associate Dean of the school of music for four years and then resigned to become head of the composition department where he designed a new media program that introduced interactive technology as part of the curriculum.²³ By 1978, Morton Subotnick, and colleagues Reynolds and Rands had produced five annual internationally acclaimed new music festivals.²⁴

In 1979, his residency at IRCAM (Paris, France) led to experimentation with IRCAM's state-of-the-art 4C computer in conjunction with his own Buchla Synthesizer. His composition *Accent into Air* was a direct result of this creative work.²⁵ For the next three years, Subotnick pursued extensive research in electronic music. In 1981, he was invited to be artist-in-residence at the Massachusetts Institute of Technology (MIT).

Subotnick explains that his goals at MIT were “a) to see if I had the aptitude to work with

¹⁹ Morton Subotnick, "Biography," *Morton Subotnick Biography*, <http://www.mortonsubotnick.com/about.html> (accessed December 15, 2008).

²⁰ Ibid

²¹ Ibid

²² Ibid

²³ Ibid

²⁴ Ibid

²⁵ Ibid

the more complex technology than the analog stuff and b) to see if I could create or find a way to create with a small computer some kind of software that would allow performers to interact directly with the computer system—because there was none at the time.”²⁶

While at the Institute, Subotnick began developing his interactive computer software *Interactor* with a small grant from the Yamaha Corporation. As fate would have it, Miller Puckette, the developer of *Max/MSP*, (the current industry standard of interactive computer software) was working on his own interactive computer research at MIT during the exact same time. Subotnick remembers his encounter with Puckette:

That’s when *Max* was being written. Miller Puckett was there [at MIT] as a graduate student and we shared experiences. It wasn’t *Max* at that point, he was translating something else, but we won’t go into that. But, it became *Max* over the years. Yamaha offered to give me money to hire someone to do the programming with the algorithms I created at MIT so I hired a student at CalArts to work for me—Marc Coniglio, and that’s how he got started. *Isadora* and that stuff that he’s made came out of that whole thing. *Interactor* existed for a while, and then I didn’t continue it and Coniglio went on to *Isadora*, and *Max* had come out so it really wasn’t necessary as a thing to continue. But, that is how it got started.²⁷

In 1982 Subotnick completed his research sabbaticals at IRCAM and MIT and returned home to California. He was immediately immersed in his demanding administrative duties at CalArts. The rigors of academic life took its toll on composing and he soon felt pressure to become independent of academic institutions.²⁸ In 1983, Subotnick moved to Pecos, New Mexico in an attempt to live solely on the income from composing and commissions. He explained that, “I was making the decision to leave CalArts and make a living at what I did [as a composer]. It was very inexpensive to live

²⁶ Morton Subotnick, interview by Jeff Heisler, *Live Interview with Morton Subotnick Regarding In Two Worlds*, (June 14, 2008).

²⁷ Ibid

²⁸ Ibid

in Pecos, New Mexico.”²⁹ In 1984, he received two major commissions: a multimedia work, *Hungers*, and a saxophone concerto, *In Two Worlds*. Subotnick recalls,

I was writing a multimedia piece called *Hungers* at the same time that I received the commission for *In Two Worlds* and I merged the writing of the two pieces for expedience sake. I could not possibly write two different pieces within the necessary time period of two years. In order to make a living at it, I could not just say no and not take the commission. I really had to do it. It was actually having to do this that caused me to go back part time to CalArts, because I couldn’t see myself continuing that kind of output.³⁰

Subsequently, Subotnick moved back to CalArts in 1985 where he held the Mel Powell Chair of Composition until his retirement in 2006.³¹

Currently, Subotnick is focused on music education for young children and he is developing a curriculum entitled *Creating Music* based on his CD-ROM series and website.³² He is also collaborating with the Library of Congress in preparing an archival presentation of his electronic works. Subotnick lives in New York City with his wife, renowned vocalist and composer, Joan La Barbara.³³

²⁹ Morton Subotnick, interview by Jeff Heisler, *Live Interview with Morton Subotnick Regarding In Two Worlds*, (June 14, 2008).

³⁰ Ibid

³¹ Ibid

³² www.creatingmusic.com

³³ Morton Subotnick, "Biography," *Morton Subotnick Biography*, <http://www.mortonsubotnick.com/about.html> (accessed December 15, 2008).

1.2: COMPOSITIONAL ACTIVITY AND SIGNIFICANCE

Today Morton Subotnick is recognized as one of the pioneers in the development of electronic music and an innovator combining live musicians with interactive computer music systems. His music frequently calls for interactive computer, or live electronic processing; and he has pioneered many of the important technological breakthroughs in the history of electro-acoustic music.³⁴ According to Subotnick's website,

The work which brought Subotnick celebrity was *Silver Apples of the Moon*. Written in 1967 using the Buchla modular synthesizer (an electronic instrument built by Donald Buchla utilizing suggestions from Subotnick and Ramon Sender), this work contains innovative synthesized tone colors with control over pitch material that many other contemporary electronic composers had relinquished.³⁵

Silver Apples of the Moon is of particular significance as the first composition in history created specifically for a recording medium (long playing vinyl disc); meaning it absolutely was not conceived for live performance. Morton Subotnick himself gives the program notes in the original record cover as released by Nonesuch in 1967:

The title *Silver Apples of the Moon*, a line from a poem by Yeats, was chosen because it aptly reflects the unifying idea of the composition.

The work is entirely electronic and was composed and realized at my studio in the School of Arts at New York University. The piece, which as composed especially for this Nonesuch release, is in two major sections that correspond to the two sides of the record. The idea of writing a work especially for a recording presents the composer with a rather special frame of reference . . . it is not the reproduction of a work originally intended for the concert hall . . . rather it is intended to be experienced by individual or small groups of people listening in intimate surroundings . . . a kind of chamber music 20th century style.

³⁴ Morton Subotnick, "Biography," *Morton Subotnick Biography*, <http://www.mortonsubotnick.com/about.html> (accessed December 15, 2008).

³⁵ Ibid

The modular electronic music system (which is the core of my NYU studio) was built by Donald Buchla for Ramon Sender and myself at the San Francisco Tape Music Center. The three of us worked together for more than a year to develop an electronic music “machine” that would satisfy our needs as composers. The system generates sound and time configurations, which are predetermined by the composer through a series of “patches” consisting of interconnecting various voltage-control devices. It is possible to produce a specific predetermined sound event . . . and it is also possible to produce sound events that are predetermined only in generalities . . . this without deciding on the specific details of the event . . . and listen . . . and then make final decisions as to the details of the musical gesture. This gives the flexibility to score sections of the piece in the traditional sense . . . and to mold other sections (from graphic and verbal notes) like a piece of sculpture.³⁶

In 1975, Subotnick wrote *Until Spring*, a composition for solo synthesizer. In this work, changes in timbre settings made in real-time on the synthesizer were stored as control voltages on a separate tape, enabling Subotnick to duplicate any of the performance parameters, and to subsequently modify them without latency.³⁷ While the use of control voltages was not a new innovation, its use to gain exact control over real-time electronic processing equipment was progressive for electronic music of the 1970s.³⁸

Subotnick's invention and development of the “ghost box” marked his next innovation in the genre of voltage control. The “ghost box” is an electronic device consisting of a pitch and envelope follower for a live signal along with the subsequent voltage controlled units: an amplifier, a frequency shifter, and a ring modulator to modify the live signal. The control voltages for the “ghost box” were originally stored on a magnetic tape but are now updated to computer chip. Because the tape (or computer chip) does not actually produce sound, Subotnick refers to the modification of the sound generated by the live signal as a “ghost score.” Written in 1977, *Two Life Histories* was

³⁶ Morton Subotnick, *Silver Apples of the Moon*, comps. Morton Subotnick, 1967.

³⁷ Latency is a measure of time delay experienced in a system.

³⁸ Morton Subotnick, “Biography,” *Morton Subotnick Biography*, <http://www.mortonsubotnick.com/about.html> (accessed December 15, 2008).

the first composition involving his new live sound modification. Over the next six years Subotnick was devoted to composing works for live performers and “ghost scores.” The sophistication and control over real-time electronic processing in these innovative works secured his reputation as one of the world's most important electronic music composers.³⁹

In 1979, Subotnick expanded his research at IRCAM (Paris, France) by experimenting with live electronic processing in his work *Ascent Into Air*. Here he used IRCAM's state-of-the-art 4C computer in conjunction with his own Buchla 300 synthesizer as a computerized replacement for his "ghost box." According to Mark Ballora,

In addition to the parameters Subotnick had used for his own ghost scores, the 4C allowed him to locate sounds within a quadraphonic field as well as change the timbres through various filters. The parameters of these effects were controlled by elements of the input from live performers, so that the "ghost" parameters were realized as the performance was taking place, rather than being recalled from tape.⁴⁰

Perhaps the most significant aspect of Subotnick's IRCAM work was the development of the opposite parameters of his “ghost score” compositions. Here he found ways to use live performers to control the computer parameters and, in effect, serve as control voltages to influence where a sound is placed, how it is modulated and by how much.⁴¹ This realization of real-time electronic processing lead to Subotnick's research and ultimate creation of the interactive computer software *Interactor*.

³⁹ Morton Subotnick, "Biography," *Morton Subotnick Biography*, <http://www.mortonsubotnick.com/about.html> (accessed December 15, 2008).

⁴⁰ Mark Ballora, "IRCAM History," *IRCAM History*, <http://www.music.psu.edu/Faculty%20Pages/Ballora/INART55/IRCAM.html> (accessed December 20, 2008).

⁴¹ Morton Subotnick, "Biography," *Morton Subotnick Biography*, <http://www.mortonsubotnick.com/about.html> (accessed December 15, 2008).

Subotnick's works from the 1980s and early 1990s (e.g. *In Two Worlds*, *Jacob's Room*, *The Key to Songs*, *Hungers*, *And the Butterflies Begin to Sing*, and *A Desert Flowers*) utilize commercially available MIDI⁴² computerized sound generation, in conjunction with his software *Interactor* which features "intelligent" computer controls allowing the performers to directly interact with the computer technology.⁴³

⁴² MIDI: Musical Instrument Digital Interface. Through MIDI, all electronic keyboards (and electronic wind instruments, guitars, and drum machines) could connect to computers for interactive sequencing, sound manipulation, playback, and recording,

⁴³ Morton Subotnick, "Biography," *Morton Subotnick Biography*, <http://www.mortonsubotnick.com/about.html> (accessed December 15, 2008).

CHAPTER II. HISTORY AND SIGNIFICANCE OF *IN TWO WORLDS*

2.1: THE COMMISSION

Morton Subotnick's *In Two Worlds* was commissioned in 1984 with a National Endowment for the Arts Consortium Grant initiated by saxophonists Kenneth Radnofsky (New England Conservatory), John Sampen (Bowling Green State University), and James Forger (Michigan State University). The NEA award of \$18,000 was significant for this time period and the consortium grant was specifically designed for the commissioning of new music for the saxophone.⁴⁴ In addition to *In Two Worlds*, other works from this project included Donald Martino's *Concerto* for Alto Saxophone and Chamber Orchestra and Milton Babbitt's *Whirled Series* for Alto Saxophone and Piano.⁴⁵

The performing consortium consisted of saxophonists, John Sampen, Kenneth Radnofsky, and James Forger.⁴⁶ Each member of the commissioning consortium organized at least two performances for each work. In addition, each saxophonist was assigned one world premiere, which included special collaboration with the composer.⁴⁷ Radnofsky prepared and premiered Martino's *Concerto*, Forger played the first performance of Babbitt's *Whirled Series*, and Sampen premiered Subotnick's *In Two Worlds*.⁴⁸

⁴⁴ Susan McDonald, "Sampen to introduce New Saxophone," *Monitor: Bowling Green State University*, January 11, 1988.

⁴⁵ Ibid

⁴⁶ Kenneth Radnofsky, e-mail conversation with Jeff Heisler, *Subotnick: In Two Worlds* (July 20, 2009).

⁴⁷ Ibid

⁴⁸ Susan McDonald, "Sampen to introduce New Saxophone," *Monitor: Bowling Green State University*, January 11, 1988.

Sampen briefly explains the details of the commission in a letter to John Hancock of the Toledo Symphony dated September 24, 1984:

Mr. John Hancock
1 Stranahan Square
Toledo, OH 43604

Dear John:

Enclosed are materials concerning our proposed consortium saxophone grant to the NEA, which will hopefully involve the Toledo Symphony Orchestra in the world premiere of Morton Subotnick's composition for alto saxophone and orchestra. Also enclosed is a biography on Subotnick, which may be of background interest.

Briefly, our proposal involves saxophonists Kenneth Radnofsky, James Forger, and myself who each will premiere new music by composers Milton Babbitt (music for saxophone and piano), Donald Martino (music for chamber orchestra and saxophone), and Morton Subotnick (music for saxophone and full symphony orchestra). The premieres are tentatively slated for the 1986–87 concert season.

Please call or write if you need further information. I believe this is an outstanding opportunity for both the TSO and myself and I am very excited about working with the symphony and Mr. Subotnick on this new work.

Sincerely,

John Sampen
Professor of Saxophone⁴⁹

It is acknowledged within the consortium that Kenneth Radnofsky undertook much of the project's groundwork and writing of the NEA grant. He enjoyed a close relationship with composers Milton Babbitt and Donald Martino and this friendship was valuable in securing their participation.⁵⁰ Radnofsky also nominated Subotnick as a third consortium composer.⁵¹ In an e-mail conversation with the author, Radnofsky discloses

⁴⁹ John Sampen, "Letter to Toledo Symphony Regarding Subotnick" (September 24, 1984).

⁵⁰ Kenneth Radnofsky, e-mail to Jeff Heisler, *Subotnick: In Two Worlds Commission* (July 20, 2009).

⁵¹ Ibid

his rationale for choosing Subotnick, “We [Radnofsky, Sampen, and Forger] respected his [Subotnick’s] work very much and understood his importance to the electronic music genre. Plus, we wanted to commission works by ‘cutting-edge’ composers who were at the forefront of new music.”⁵²

In support of the NEA grant, Yuval Zaluouk, former music director and conductor of the Toledo Symphony Orchestra (1980–1989), wrote a letter to the NEA announcing the premiere performance of *In Two Worlds* with the Toledo Symphony during its 1986–1987 concert season. The letter, dated August 27, 1984, reads as follows:

National Endowment for the Arts
Nancy Hanks Center
1100 Pennsylvania Ave., N.W.
Washington, D.C. 20506

Dear Sirs:

I am delighted to learn of the Saxophone Commissioning Consortium initiated by saxophonists James Forger, Kenneth Radnofsky, and John Sampen. This project, which involves major new compositions by composers Morton Subotnick, Milton Babbitt, and Donald Martino, promises to add significant works to the saxophone’s youthful repertoire.

Mr. Sampen has recently approached the Toledo Symphony Orchestra for the honor of premiering Morton Subotnick’s commissioned work for alto saxophone and symphony orchestra. As music director of the Toledo Symphony, I am pleased to offer my support for this proposal by tentatively scheduling such a premiere with saxophonist John Sampen during our 1986–1987 concert season. The Toledo Symphony was so recognized in 1984 with a first place ASCAP Award for Progressive Programming. Additionally, Mr. Sampen has achieved an outstanding reputation as a specialist in contemporary music. We are excited about the opportunity to collaborate with John Sampen and Morton Subotnick on this important project and we urge the successful funding of the consortium commission.

With respect,
Yuval Zaliouk⁵³

⁵² Kenneth Radnofsky, e-mail to Jeff Heisler, *Subotnick: In Two Worlds* (July 20, 2009).

⁵³ Yuval Zaliouk, "Letter to the National Endowment of the Arts" (Toledo, OH, August 27, 1984).

Figure 2: Subotnick, Zaliouk, and Sampen (1987 Toledo Symphony Premiere)



Zaliouk added weight to the combined efforts of Radnofsky, Sampen, and Forger, in helping secure the necessary NEA funding for commissioning Subotnick's *In Two Worlds*.

At the time of the commission in 1984, Morton Subotnick was living solely on income from the composition of music.⁵⁴ This career choice offered freedom from the demands of teaching in higher academia, but it also promised financial instability. Looking to reduce living costs, Subotnick moved his home to Pecos, New Mexico

⁵⁴ Morton Subotnick, interview by Jeff Heisler, *Live Interview with Morton Subotnick Regarding In Two Worlds*, (June 14, 2008).

because, “it was very inexpensive to live there.”⁵⁵ Here, Subotnick began work on a commission entitled *Hungers*, a multimedia piece scored for voice, dancer, two Air Drums⁵⁶, Kat (a midi mallet instrument), Raad (an electric cello), Yamaha Clavinova (a digital piano), YCAMS⁵⁷, and a Macintosh Plus computer.⁵⁸

When Subotnick received the commission for *In Two Worlds* he was still involved in the creation of *Hungers*. In his efforts to sustain a living exclusively through composition, Subotnick needed multiple projects, prompting his choice to write both works simultaneously. This seems to justify his use of similar musical material in both compositions. Subotnick explains his rationale, and the events leading to the commissioning of *In Two Worlds* in an interview with the author:

Well first of all, *In Two Worlds* was written around 1984, but the process actually started a little before because, at that particular point in time, I was relocating my home to Pecos, New Mexico. I was making the decision to leave CalArts and make a living at what I did [as a composer]. It was very inexpensive to live in Pecos, New Mexico. I was writing a multimedia piece called *Hungers* at the same time that I received the commission for *In Two Worlds* and I merged the writing of the two pieces for expedience sake. I could not possibly write two different pieces within the necessary time period of two years. In order to make a living at it, I could not just say no and not take the commission. I really had to do it. It was actually having to do this that caused me to go back part time to CalArts, because I couldn't see myself continuing that kind of output.

So, in the multimedia piece called *Hungers* and the concerto *In Two Worlds*, there are whole sections that go back and forth between the two pieces. They co-existed. When you look historically, you will see that almost any composer trying to work exclusively from writing music, you will find this same back and forth process. I didn't realize that at the time, and I decided that I didn't want to do that

⁵⁵ Morton Subotnick, interview by Jeff Heisler, *Live Interview with Morton Subotnick Regarding In Two Worlds*, (June 14, 2008).

⁵⁶ The Air Drum is a device that consists of a hand held baton that is capable of detecting six directions of motion and the general velocity of these motions. They, in turn, send the sensed information to the computer, which then incorporates that information appropriately.

⁵⁷ YCAMS or Yamaha Computer Assisted Musical System is comprised of a QX-1, QX-5 (score performance devices or sequencers) and two TX-816s (FM sound generating devices).

⁵⁸ Morton Subotnick, "Hungers," 1988, http://90.146.8.18/en/archiv_files/19881/E1988_065.pdf (accessed November 11, 2009).

[living only from composing] so I stopped. As a result, these two pieces are linked together.⁵⁹

Indeed *Hungers* and *In Two Worlds* are musically and technologically linked through their shared musical material⁶⁰ and technologies such as the Air Drum and *Interactor*.

⁵⁹ Morton Subotnick, interview by Jeff Heisler, *Live Interview with Morton Subotnick Regarding In Two Worlds*, (June 14, 2008).

⁶⁰ Musical sections such as “Combat Dance” and “Alone” are shared between *In Two Worlds* and *Hungers*.

2.2: TECHNOLOGY

In Two Worlds was at the forefront of late 20th century electronic music innovation as one of the first pieces to involve interactive electronics with the saxophone. Subotnick's original conception of *In Two Worlds* was a concerto for saxophone, wind controller, computer, and orchestra.⁶¹ The initial orchestration featured solo alto saxophone (doubling on the Yamaha WX7 wind controller), piccolo, 2 flutes, 2 oboes, 2 clarinets, bass clarinet, 2 bassoons, contrabassoon, 4 horns, 2 trumpets, 2 trombones, tuba, percussion, harp, strings, conductor (using the Air Drum), and computer (using *Interactor*).⁶²

Early concert programs describe *In Two Worlds* as a "Concerto for Alto Saxophone, Yamaha WX7 Wind Controller, Computer, "Air Drum" and Orchestra."⁶³ Subotnick says, "*In Two Worlds* refers both to the duality of the media [computer and traditional orchestral instruments] and to the synthesis of the musical material, which consist of recent and more modal concepts of musical language."⁶⁴

In the original program notes, Subotnick took the unusual step to educate the audience and explain his electronic innovations:

A note about the technology: the Yamaha WX7 Electronic Wind Controller is a new musical instrument which allows the performer's musical gestures to be transformed into digital signals,⁶⁵ which can then be translated into specially created sounds. The digital signals can also be read by the computer so that it will be "aware" of the exact location of the performer in the score. The "Air Drum" is a new device created by Palm Tree Electronics, which senses six directions of

⁶¹ John Sampen, "Archive: Original Event Structure for Sax Concerto" (1987).

⁶² *In Two Worlds* Orchestration: 2(w/pic)22bclar2cbssn/4221/perc/harp/strings

⁶³ Morton Subotnick, "In Two Worlds - New Mexico Symphony Program Notes," *New Mexico Symphony Program* (New Mexico Symphony, 1988).

⁶⁴ Ibid

⁶⁵ "Musical gestures" such as musical phrases, articulations, and dynamics; not physical movements.

motion and can therefore be adapted for use by a conductor. In this case, it is used to control the starts and stops [cues] that the computer produces, while the traditional baton [in the conductor's other hand] cues the instrumentalists. The MAC computer acts as a central "clearing house" where all the digital signals are processed through the software [*Interactor*] specially designed to allow for this performer—computer interaction. The sound-producing modules are the Yamaha TX802⁶⁶ and SPX90.⁶⁷ The audio mix is also programmed through the MAC computer and utilizes the new Yamaha audio mixer DMP7.⁶⁸

In Two Worlds was the first classical composition written specifically for the WX7 Wind Controller and the unique technology such as the Air Drum combined with the live effects processing of the Yamaha SPX90 (using interactive computer controls) warranted the above explanation from the composer.

The software *Interactor* was another important innovation in the interactive computer music genre. Written and developed by Marc Coniglio under the supervision of Subotnick, the software was designed to operate on a Macintosh II⁶⁹ computer system. It contains its own music playback (using MIDI), the musician's part, instructions for the audio mixer, and instructions for the digital sound modules (Yamaha TX802, and SPX90). Essentially, the software controls the audio mixer and sound modules while playing its own part and listening to the live performer.⁷⁰

Subotnick discusses his role in the creation of *Interactor* in an interview with this author:

⁶⁶ Released in 1987, the Yamaha TX802 is a FM Synthesizer used to create electronic (MIDI) sounds

⁶⁷ Released in 1987, the Yamaha SPX90 is a reverb and multi-effect processor used to manipulate sounds in real time (without latency).

⁶⁸ Morton Subotnick, "In Two Worlds - New Mexico Symphony Program Notes," *New Mexico Symphony Program* (New Mexico Symphony, 1988).

⁶⁹ The Macintosh II computer was released March 2, 1987 and discontinued on January 15, 1990. The CPU contained a Motorola 68020 @ 16 MHz with 1 MB of memory (expandable to 20 MB). (<http://oldcomputers.net/macintosh.html>)

⁷⁰ Morton Subotnick, "Biography," *Morton Subotnick Biography*, <http://www.mortonsubotnick.com/about.html> (accessed December 15, 2008).

Well, *Interactor* was what Yamaha was giving me some money to develop and *Max* [*MSP*] hadn't come into being yet. In fact I was brought to MIT as an artist-in-residence in the 1980s and my goals were: a) to see if I had the aptitude to work with the more complex technology than the analog stuff and b) to see if I could create or find a way to create with a small computer some kind of software that would allow performers to interact directly with the computer system—because there was none at the time. That is why I called it *Interactor*. I found out that yes, I did have the aptitude because in three months I actually created it. But, it was a prototype that didn't work in real time because not only was the computer small but the stuff I was working on at MIT was in such a raw state that I could only prove it would work, but I couldn't actually use it. That's when *Max* was being written. Miller Puckett was there [at MIT] as a graduate student and we shared experiences. It wasn't *Max* at that point, he was translating something else, but we won't go into that. But, it became *Max* over the years. Yamaha offered to give me money to hire someone to do the programming with the algorithms I created at MIT so I hired a student at CalArts to work for me—Marc Coniglio, and that's how he got started. *Isadora* and that stuff that he's made came out of that whole thing. *Interactor* existed for a while, and then I didn't continue it and Coniglio went on to *Isadora*, and *Max* had come out so it really wasn't necessary as a thing to continue. But, that is how it got started.⁷¹

The Yamaha WX7 Wind Controller and Air Drum had the capabilities to change timbres and articulations, as well as trigger changes in dynamics and tempo. However, *Interactor* was programmed by Subotnick to have the capabilities to actually “interact” with the live soloist performing on a traditional alto saxophone⁷² by the soloist triggering computerized sound samples via foot pedal and initiating real-time effects processing to the sound of the saxophone soloist.⁷³ Subotnick's *Interactor* patch controlled three, real-time effects: reverb, delay, and pitch shifting, (using the Yamaha SPX90 Digital Multi-Effect Processor) which processed the sound from the live performer. The exact real-time effects patches in *In Two Worlds* are seen in Figure 3 below.

⁷¹ Morton Subotnick, interview by Jeff Heisler, *Live Interview with Morton Subotnick Regarding In Two Worlds*, (June 14, 2008).

⁷² The saxophonist performed into a microphone, which captured the signal and triggered the computer (*Interactor*) to initiate the Yamaha SPX90 multi-effect processor for sound manipulation in real-time (or with very little latency).

⁷³ *Interactor* is generally considered a predecessor to Cycling '74's *Max/MSP* interactive computer program developed at IRCAM by Miller Puckette.

Figure 3: Interactive Live Processing Effects
(In Two Worlds – Interactor)^{74 75}

Reverb 1: Large Hall	1.4 sec. reverb time, all filters thru
Reverb 2: Large Hall	6.0 sec. reverb time w/30ms delay
Reverb 3: Plate	1.0 sec. reverb time w/10ms delay
Delay 1	Left (148ms, 5%feedback), Right (280ms, 2% feedback)
Delay 2	Left (250ms, 15%feedback), Right (200ms, 15% feedback)
Delay 3	Left (110ms, 4% feedback), Right (225ms, 3% feedback)
Pitch Shift 1	Pitch 1 = (up m3rd, fine-tuned +9 cents, 22ms delay) Pitch 2 = (up TT, fine-tuned -4 cents, 6.3ms delay)
Pitch Shift 2	Pitch 1 = (down TT, fine-tuned -5 cents, 22ms delay) Pitch 2 = (up M3rd, fine-tuned 0 cents, 6.5 ms delay)

The above chart shows eight different processing effect settings for *In Two Worlds*.⁷⁶ The computer, using *Interactor*, instructs the SPX90 to change between different patches at specific moments in the piece. Reverb 1 is a large setting with 1.4 seconds of reverb time. Reverb 2 is even larger with 6.0 seconds of reverb time and 30 milliseconds of delay (before the reverb is actuated). Reverb 3 is a small “plate”⁷⁷ reverb that features one second of reverb time and 10 milliseconds of delay. The live processing delay effect sends a delayed signal of the live performer’s input at different intervals. For example, Delay 1 features a left channel delay of 148 milliseconds and a 280 millisecond delay in the right channel. This varied delay discrepancy gives the overall effect more chaotic activity. As for pitch shifting, the SPX90 settings are configured to output two different pitches based on the live performer’s input detected by the computer.

⁷⁴ Morton Subotnick, “Interactor settings for *In Two Worlds*,” 1992. (Processing performed by the Yamaha SPX90 Multi-Effect Processor).

⁷⁵ These *Interactor* settings were approximated to replicate original sound when transferred to Max/MSP by Jeff Heisler and Mark Bunce in 2007.

⁷⁶ Processing performed by the Yamaha SPX90 Multi-Effect Processor.

⁷⁷ An early reverberation process, a “plate reverb” recreates the reverberation system of capturing bouncing sound waves from the vibration of a sound into a large “plate” of sheet metal.

Once the input pitch is detected, the multi-effect processor shifts the sound to the specified pitches.⁷⁸ Pitch no. 1 is sent to the right channel and pitch no. 2 is outputted to the left channel. In addition, the computer “de-tunes” the pitches and delays the output by a specific parameter according to the patch.

Inventor and engineer, Pat Downes, developed the Air Drum technology at Palmtree Instruments. Subotnick was aware of this baton technology in the early 1980s and he saw immediate potential for its use in both *Hungers* and *In Two Worlds*. The instrument can sense six directions of motion and therefore can be adapted for use by a conductor. With *In Two Worlds*, the conductor held the Air Drum with the left hand and used the instrument for advancing sound scenes, as well as other communications with the computer. The director’s right hand was used for normal conducting procedures. Subotnick discusses his thoughts on the Air Drum in a live interview with this author:

Yes, it was [the Air Drum] experimental at the time. I later had the same technology turned into a MIDI baton, which was included in a piece performed in Carnegie Hall. The conductor used the baton and the technology looked at [or sensed] all the directions of the wrist. This instrument [Air Drum] was made by Palmtree Instruments. A few people had it, and it never became well known, but I worked with them and they tuned it for me.⁷⁹

Ultimately, the Air Drum technology proved unreliable and eventually was removed from *In Two Worlds*.

⁷⁸ Mark Bunce recalls early experimentation with a pitch-to-MIDI converter, the “IVL Pitchrider 7000 MKII.” A microphone was connected to the input of the “Pitchrider,” which would sense the pitch of the saxophone and convert it to MIDI pitch data. That in turn would be used by *Interactor* to trigger various events in the piece. However, the “IVL Pitchrider” proved to be too problematic and inconsistent to ensure a reliable live performance. Pitches would be detected incorrectly or not at all, triggering wrong events at inappropriate times. The IVL technology was scrapped fairly early and never used in a live performance of *In Two Worlds*.

⁷⁹ Morton Subotnick, interview by Jeff Heisler, *Live Interview with Morton Subotnick Regarding In Two Worlds*, (June 14, 2008).

new concerto, even though the instrument was not yet commercially available. In fact, at the time of the scheduled premiere in 1987, (the soloist) John Sampen still had not acquired or even played the wind controller and thus could not perform the entire work. On October 16, 1987, Sampen premiered only the second half (Part II) of the concerto with the Toledo Symphony Orchestra. The first half of *In Two Worlds* was omitted since the score called for the soloist to perform exclusively on the WX7 Wind Controller.⁸²

Subotnick describes his role in the development of the wind controller technology in the excerpt below:

As for the wind controller, Yamaha had given me some money for the development of the instrument. It was a small amount, but it was enough for me to deal with it. In exchange, I said they could not have anything, they couldn't use my name, they couldn't do anything and they said "that's fine." They didn't have any ownership of it [my work and experiments], but they would like to just be able to keep in contact and come in and see what I was doing and they would be happy to show me what they were doing. So they brought a contingent of engineers from Japan to visit me in Pecos. With them they brought the original wind controller, which at the time, was a phenomenal saxophone. It had everything—almost too much. This was around the early 1980s, I don't know the exact year. They gave me a prototype to use. The problem was that almost no one could play it—the instrument was too complicated. The thumb part [octave keys] was probably the worst because you would barely touch it and it would go up two octaves. So, if you were used to a saxophone, you just couldn't do it. It was too hard, so they made a simpler version. John [Sampen] did a good job with it, but no one else was going to play it. I think if I'm not mistaken, the original concerto had a regular saxophone in it. So, I translated it back to saxophone using the processing (the DSP) and that is the way it ended up. But, at first, the idea was to use it [the wind controller]. The idea was nice, but I found that it was not satisfying in that one didn't need a saxophone player, a keyboard player could do it. So, I decided that it was a nice idea that wasn't a nice idea. And I like the saxophone much better because you really know the person is playing—and that's important.⁸³

⁸² Part II of *In Two Worlds* is specifically scored for solo alto saxophone without wind controller.

⁸³ Morton Subotnick, interview by Jeff Heisler, *Live Interview with Morton Subotnick Regarding In Two Worlds*, (June 14, 2008).

Figure 5: John Sampen and the WX7 Wind Controller

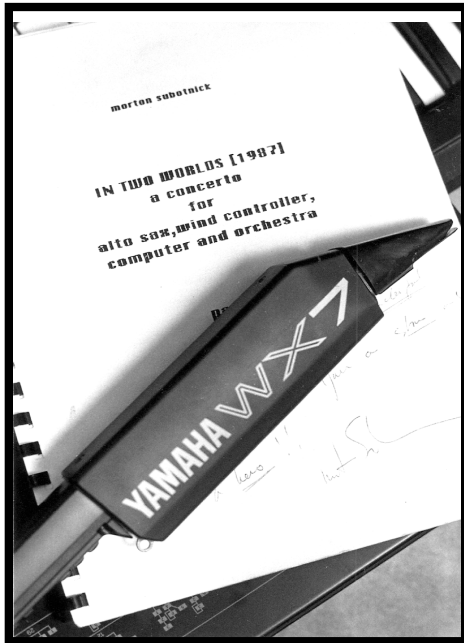

Subotnick continues to describe the inherent problems with the wind controller:

Well, I think it is an ill-conceived notion. First of all, you learn a saxophone, or any instrument, and it becomes part of your nervous system and you don't really think about what you are doing—you just do it. And you cannot do that on a new instrument. You can learn it, and you can learn to play some things, but you will never be able to [really] do it. So, the idea of the wind controller was a good one in that they really tried to make it like a saxophone and you could transfer your technique over to it. If you are in the studios and you are doing music for a film where you don't see the person play and you want to pay less money, you might have that “wind controlling” person do things you couldn't on the keyboard and you could make crescendos and do all of those things easier than you can do with the [keyboard] wheel and maybe be more effective. But, as a concert instrument, it really doesn't make it. Since you are doing everything you do well anyway, you might as well use what you do. If you can't tell that you are doing it, you might as well play keyboard. This is an extremely interesting issue and in many ways pinpoints some of the major issues we have with technology and performance. So, I think eventually that it isn't going to work. It will stay there in the synthesizer domain—wherever that makes sense for it to be.⁸⁴

⁸⁴ Morton Subotnick, interview by Jeff Heisler, *Live Interview with Morton Subotnick Regarding In Two Worlds*, (June 14, 2008).

The Yamaha Corporation has continued to develop and improve wind controller technology and since 1987 the company has introduced two new generations—the WX11 and WX5 respectively. In addition, the Akai Professional Corporation has been an active participant in marketing wind controllers with its highly successful EWI (Electronic Wind Instrument) line. Despite their limitations, wind controllers have enjoyed limited popularity for some classical and jazz wind musicians who wish to expand their sonic palettes.

2.3: PREMIERES AND PROBLEMS

In Two Worlds has evolved through many revisions and each has had its own first performance (see Figure 6). The opportunity for these multiple premieres was particularly important in attracting attention and subsequent publicity that accompanied each concert. In addition, these premieres provided opportunities for Subotnick to revise and retool the work for more reliable future performances.

Figure 6: World Premieres of different versions of Subotnick’s *In Two Worlds*⁸⁵

<u>Version</u>	<u>Soloist / Ensemble</u>	<u>Premiere Date</u>
Partial Version - Part II: for Saxophone, Orchestra, and Computer	John Sampen, soloist The Toledo Symphony Orchestra Yuval Zaliouk, conductor Peristyle, Toledo Museum of Art Toledo, Ohio	October 16, 1987
Full Version: for Saxophone, WX7 Wind Controller, Air Drum, Amplified Orchestra, and Computer	John Sampen, soloist The Electric Symphony Orchestra Richard Gonski, conductor The Corn Exchange Cambridge, England	January 16, 1988
U.S. Premiere of Full Version: for Saxophone, WX7 Wind Controller, Air Drum, Orchestra (non-amplified), and Computer	John Sampen, soloist New Mexico Symphony Orchestra Neal Stulberg, conductor Popejoy Hall, University of New Mexico Fine Arts Center Albuquerque, New Mexico	March 11, 1988
Solo Yamaha WX7 Electronic Wind Controller and Computer	Kenneth Radnofsky, soloist MIT Media Lab Boston, Massachusetts	April 14, 1988 ⁸⁶
Solo Alto Saxophone and Computer (without wind controller and orchestra)	John Sampen, soloist Guest Artist Series University of California at Los Angeles	January 16, 1990

⁸⁵ John Sampen, data collected from John Sampen’s archive of *In Two Worlds* premiere(s) concert programs.

⁸⁶ Subotnick, Radnofsky, and Sampen do not have record of this concert, however, according to MIT labs the premiere was on a concert entitled “The ‘Binary Convergence’ at MIT’s Experimental Media Facility (The CUBE) featuring live computer/performer works by Morton Subotnick, David Arzouman, Javier Alvarez, Jonathan Harvey, and Mario Davidovsky (April 14, 1988). (e-mail correspondence with MIT program manager Helen Curley <hcurley@media.mit.edu> December 8, 2009)

Full Version: with Saxophone, Computer, and Orchestra (without wind controller and Air Drum) (Shortened Orchestral Version)	John Sampen, soloist Orchestra Internazionale D' Italia Lu Jia, conductor 10th World Saxophone Congress Pesaro, Italy	September 6, 1992
Solo Alto Saxophone and Interactive Computer (<i>Max/MSP</i>) Programmed by Jeff Heisler and Mark Bunce ⁸⁷	Susan Fancher, soloist Weatherspoon Art Gallery University of North Carolina at Greensboro New Music Festival Greensboro, North Carolina	October 25, 2007

As already mentioned, the first world premiere of *In Two Worlds* featured a shortened version consisting only of Part II⁸⁸ and was performed by saxophonist John Sampen with the Toledo Symphony Orchestra on October 16, 1987 (see Figure 7).

Figure 7: World Premiere Performance of *In Two Worlds* (Toledo Symphony 1987)

◀ Forty-fourth Season
The Toledo Symphony ▶
Yuval Zaliouk, Music Director

Classics Series/Second Program

Friday, October 16, 1987 at 8 p.m.
Saturday, October 17, 1987 at 8 p.m.
Peristyle, Toledo Museum of Art

YUVAL ZALIOUK, Conductor
MISHA and CIPA DICHTER, Duo-pianists
JOHN SAMPEN, Alto Saxophonist

Dvorak Scherzo Capriccioso, Op. 66

Subotnick In Two Worlds: Part II for Saxophone, Orchestra and Computer*
alone—cadenza—alone—lullaby—cadenza—celebration—
combat dance 2

John Sampen

◆ INTERMISSION ◆

Poulenc Concerto in d minor for 2 Pianos and Orchestra
Allegro ma non troppo
Larghetto
Finale

Misha and Cipa Dichter

Ravel Rhapsodie Espagnole
Prélude à la nuit
Malaguena
Habanera
Feria

*World Premiere

The Steinway concert grand piano is a bequest from Dr. James G. Southworth.
Additional Steinway piano is courtesy of the Music Department of the University of Toledo.
Floral arrangements on stage are provided by Glendale Flower Shop and Greenhouses.
Each artist receives a hospitality basket provided by Oak Tree Wine Shop, located in the Starline Plaza.
The concert will end at approximately 9:40 p.m.
Thanks to Prudential Bache. Saturday evening's performance is being broadcast live on WGTE-WGLE FM 91.

35

⁸⁷ With input and support from Morton Subotnick.

⁸⁸ Scored for Solo Alto Saxophone, Orchestra, and Computer (without wind controller and Air Drum).

Sampen recalls two reasons for premiering an abbreviated composition:

First, Morton Subotnick was frantically composing and scoring the concerto but it was not fully completed by October of 1987. Secondly, the Yamaha WX7 Wind Controller, which was intended as the solo voice for the entire first half of the composition, was not yet commercially available and I could not acquire an instrument. Even with the omission of the wind controller segments, the “shortened” version of *In Two Worlds* comprised a massive work of over 20 minutes and offered a “musical adventure” for the soloist, composer, and orchestra. As I recall, the computer program [and subsequent sounds] were constantly crashing, causing great anxiety for all involved.⁸⁹

Sampen acquired his Yamaha WX7 Wind Controller in December of 1987. He then began immediate preparations for the full 35-minute version of *In Two Worlds* to premiere with the Electric Symphony Orchestra (Cambridge and London, England) on January 16, 1988 (see Figures 8 and 9). As mentioned earlier, this full version, scored for alto saxophone, WX7 Wind Controller, Air Drum, computer and amplified orchestra, was an immense undertaking, unveiling numerous state-of-the-art interactive innovations. The new technologies of the wind controller and Air Drum, combined with Subotnick’s new interactive computer software *Interactor* and the amplification of the entire orchestra resulted in monumental logistical problems, which accentuated the inconsistencies of the early interactive technologies.⁹⁰

There were a number of issues with the wind controller’s triggering mechanisms. In addition to performing musical gestures, the WX7 could also send computer information to “advance” electronic sounds and effects processing from one section to the

⁸⁹ John Sampen, interview by Jeff Heisler, *Regarding In Two Worlds* (December 1, 2009).

⁹⁰ Sampen also recalls that the concert organizers additionally staged a simultaneous light show during the performance.

next.⁹¹ This technology created a marvelous opportunity for the soloist to interact with the computer but the process could prove catastrophic if the live performer accidentally played a wrong note, thus sending a triggering message to the computer with instructions to change sound events at improper times. Making matters worse, the sensors in the Air Drum motion technology were unreliable and often confused the computer's musical sequence of sound events, necessitating manual "advancing" of electronic music by a sound engineer operating the sound mixer and interactive computer levels. The resulting technological chaos eventually led Subotnick to reduce the required technology in an attempt to make *In Two Worlds* reliable in live performance.

Figure 8: Electric Symphony Poster (London 1988)



⁹¹ "Advance" is the term Subotnick uses in his interactive computer language (Interactor) to tell the computer to go on to the next "sound event."

Figure 9: Electric Symphony Orchestra Program (Cambridge / London – 1988)

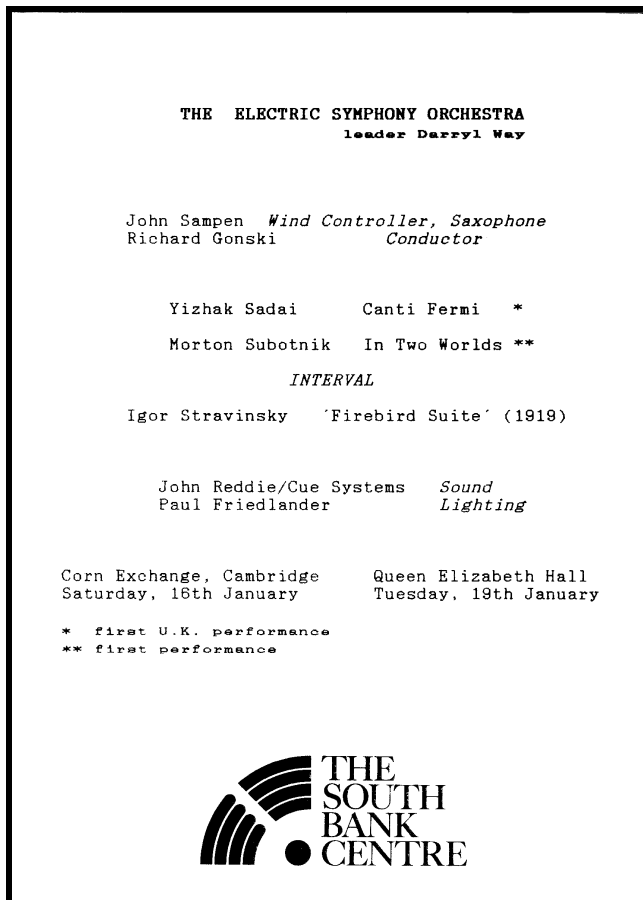

Two months later, the American premiere was presented in a full 35-minute version with John Sampen and the New Mexico Symphony (see Figure 10). Here, the concerto was performed without amplification of the orchestra. Subotnick also made the live performance more reliable by adjusting the triggering mechanisms⁹² so that computerized sound events could be manually “override-able” by an assisting computer technician.⁹³ Subotnick also adjusted the triggering by experimenting with the

⁹² Wind Controller and Air Drum were programmed to advance the computer to the next sound event.

⁹³ Manually “override-able” by a sounds technician operating the computer from the audience.

computer's range of "believability." For example, the tempo of *In Two Worlds* could be set by the soloist's performance. If the soloist played an incorrect rhythm by mistake, the computer could react with an exaggerated and inappropriate tempo. Subotnick could somewhat prevent this by programming the computer to "believe" only a small range or "window" of variability in tempo fluctuation. Even so, the technology was still in its infancy and the reliability in live performance remained a concern.

Figure 10: New Mexico Symphony Orchestra Program (1988)



CONCERT PROGRAM

SEVENTH PROGRAM

NEW MEXICO
SYMPHONY
ORCHESTRA
NEAL STULBERG
MUSIC DIRECTOR

March 11, 1988, sponsored by
*Total Business Systems and
Rodey, Dickason, Sloan, Akin & Robb, P.A.*

March 12, 1988, sponsored by
Rogoff, Diamond & Walker, CPAs
Neal Stulberg, conducting

Carl Philipp Emanuel Bach
(1714-1788) *Symphony No. 10 in B-flat Major,
Wotquenne 182, No. 2 (1773)*
*Allegro di molto
Poco adagio —
Presto*

Morton Subotnick
(1933 -) *"In Two Worlds": Concerto for Alto Saxophone,
Electronic Wind Controller, Air Drum, Computer,
and Orchestra (1987)*
Part I: 'alone' — 'rushing' — 'celebration' — 'cadenza'
*Part II: 'alone — cadenza — alone' — 'lullaby' — 'cadenza' —
'celebration' — 'combat dance 1' — 'combat dance 2'*
U.S. PREMIERE OF THE COMPLETE WORK
John Sampen, saxophone

INTERMISSION

Hector Berlioz
(1803 - 1869) *"Symphonie Fantastique," Op. 14a (1830)*
"Reveries and Passions": Largo — allegro agitato e appassionato assai
"A Ball. Valse": Allegro non troppo
"Scene in the Country": Adagio
"March to the Scaffold": Allegretto non troppo
"Dream of a Witches' Sabbath": Larghetto — Allegro

Mr. Sampen appears under the auspices of Rosalie Calabrese

Popejoy Hall/UNM Fine Arts Center
8:15 p.m.

Mr. Subotnick's residency with the NMSO is supported in part with funds provided by the Western States Arts Federation, the New Mexico Arts Division, and the National Endowment for the Arts.

NMSO gratefully acknowledges Besson's Gardens for its donation of floral stage decorations.
The UNM Art Museum will be open on March 11 and 12, 7:00 - 10:00 p.m., as a courtesy to Symphony patrons. Patrons are urgently requested to disengage audible signals on their electronic watches. Latecomers cannot be seated until a natural break occurs in the music. The use of cameras and tape recorders at Symphony concerts is prohibited. Physicians on call may register in the east cloak room.

March Program

M-11

The next world premiere featured a radical change in the concept and formal structure of *In Two Worlds*. At the MIT Media Labs, Kenneth Radnofsky premiered the solo version for Yamaha WX7 wind controller and computer on April 14, 1988.⁹⁴ The length was significantly reduced from the original 35 minutes to 20 minutes by condensing musical material from both Parts I and II. However, there were again issues with the WX7 triggering sensors, which caused problems in the live performance. Radnofsky remembers, “The computer crashed midway, because I hit a wrong note and it triggered other events [to occur at the incorrect time]. However, the second night went perfectly.”⁹⁵ Radnofsky and Sampen continued refining their performance skills on the wind controller (1988–1990) but problems remained in achieving technical accuracy. Ultimately, Subotnick chose to recast still another version—this time featuring alto saxophone and interactive computer.

This 1990 solo saxophone version (see Figure 11) was shortened to 18 minutes by using the alto saxophone as a solo voice with condensed material from both Parts I and II of the original concerto. The shortening of the work was prompted by comments Sampen received after performances of the 1988 WX7 solo version. In a letter to Subotnick, Sampen writes that the work was “a little too long and the audience seems to tune out.”⁹⁶ To eliminate the potential of computer failure, Subotnick programmed⁹⁷ the computer to perform “sound events” triggered by the soloist via a footpedal⁹⁸ playing the computer’s MIDI music and controlling the live effects processing. In another letter to Subotnick,

⁹⁴ For this version, the composition became a true solo without orchestra. The software *Interactor* was used to generate a MIDI reduction of the orchestral part (using a Yamaha TX 802 FM Tone Generator).

⁹⁵ Kenneth Radnofsky, e-mail conversation with Jeff Heisler, *Subotnick: In Two Worlds Commission*, (July 20, 2009).

⁹⁶ John Sampen, "Letter to Morton Subotnick" (February 14, 1991).

⁹⁷ Using *Interactor*.

⁹⁸ Instead of triggering sound events using the WX7 wind controller itself.

Sampen gives his support for this version by stating, “. . . this is a strong and electronically secure version of the piece. I am particularly pleased with the return to the saxophone as the solo voice.”⁹⁹ Sampen recorded this version of *In Two Worlds* on “The Contemporary Saxophone” released in 1992 by Neuma Records.

Figure 11: First Performance of Solo Alto Saxophone and Computer Version of *In Two Worlds* (1990)¹⁰⁰

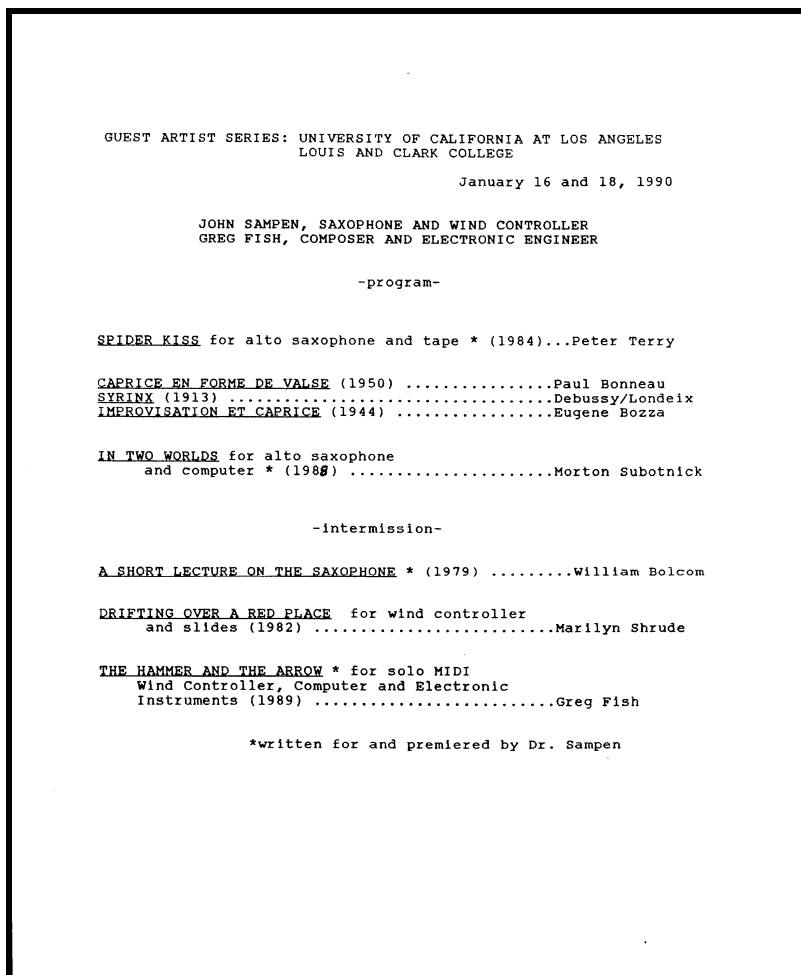

⁹⁹ John Sampen, "Letter to Morton Subotnick" (February 14, 1991).

¹⁰⁰ This is the earliest found performance of the solo alto saxophone and computer version of *In Two Worlds*. The work is not indicated as a premiere because at the time Subotnick was not considering the adaptation of the solo WX7 version to solo alto saxophone to be a new version of the work. However, because of the change in length and the return of saxophone as the solo voice, this performance is considered a premiere of this version of *In Two Worlds*.

Subotnick's final orchestral version of *In Two Worlds* was a setting for solo alto saxophone, orchestra, and computer. Sampen was again the soloist, this time performing with the Orchestra Internazionale D' Italia at the 1992 World Saxophone Congress in Pesaro, Italy (see Figure 12).

Figure 12: Pesaro, Italy World Saxophone Congress Program – 1992¹⁰¹

TEATRO ROSSINI	
21:15 / 9:15 p.m.	
ORCHESTRA INTERNAZIONALE D'ITALIA	
LU JIA, Conductor	
Program	
Jacques IBERT 1890-1962	Concertino da Camera <i>Soloist: Daniele Comoglio alto saxophone</i>
André CAPLET 1878-1925	Légende <i>Soloist: Jean-Marie Londeix alto saxophone</i>
Aleksandr KGLAZUNOV 1865-1936	Concerto in Mib Op. 109 cadenza by Khatsko Levnikhailov <i>Soloist: Paul Brodie alto saxophone</i>
Giorgio GASLINI 1929	Silver Concert World Premiere (*) <i>Soloist: Massimo Mazzoni baritone saxophone</i>
- intermission -	
Morton SUBOTNIK 1933	In Two Worlds World Premiere <i>Soloist: John Sampen alto saxophone</i>
Heitor VILLA-LOBOS 1887-1959	Fantasia Op. 630 <i>Soloist: Jean-Yves Fourmeau soprano saxophone</i>
Darius MILHAUD 1892-1974	Scaramouche <i>Soloist: Federico Mondelei alto saxophone</i>
(*) commissioned by 10th World Saxophone Congress This concert was made possible thanks to the collaboration of the Yamaha Musica Italia S.P.A.	
92	

Plagued by inconsistent success of the early interactive music technologies, the composer totally eliminated the Yamaha WX7 Wind Controller and Air Drum from the 1992

¹⁰¹ 10th World Saxophone Congress, "9:15 p.m. Concert - September 6, 1992," *10th World Saxophone Congress Program* (Pesaro, 1992).

concerto. Like the 1990 solo saxophone version, Subotnick was seeking an “electronically secure” environment for this full concerto with orchestra. Consequently, many original sections that featured the wind controller and Air Drum were eliminated, reducing the length from 35 minutes to 22 minutes. This concerto version of *In Two Worlds* is currently available for performance rental through European American Music Distributors.

During the years 1993–1996, John Sampen and Mark Bunce featured the 1990 solo saxophone version on tour with at least 16 performances in Canada and USA. After that point, the composition entered a dormant stage, primarily because the necessary equipment and technology was obsolete. The Macintosh II computer and *Interactor* were no longer commercially available after 1995, thus discouraging live performances. Saxophonist Susan Fancher presented one of the last performances of the original 1990 solo saxophone and computer version in the late 1990s while completing her doctorate at Northwestern University. By the turn of the 21st century, *In Two Worlds* had essentially become unplayable. This presented an opportunity to resurrect the piece by updating the interactive computer software to modern technology.

In the summer of 2007, Jeff Heisler and Mark Bunce retrieved the 1990 version of *In Two Worlds* and re-programmed the work in *Max/MSP*. As a result, the accompaniment of *In Two Worlds* is now currently available on an interactive computer program (*Max/MSP*) that can be performed on modern computers with great reliability and with software support guaranteed for at least the near future.¹⁰² Heisler and Bunce’s updated version of Subotnick’s *In Two Worlds* has reliable real-time effects processing

¹⁰² *Max/MSP* is currently popular with contemporary interactive programmers and the software continues to enjoy favor with IRCAM.

built into the patch that eliminates the need for external processors (such as the Yamaha SPX90) or a sound technician to manually control effects levels on reverb, delay, and pitch shifting.¹⁰³ This version was premiered by Susan Fancher at the University of North Carolina Greensboro's New Music Festival (2008 - see Figure 13) and recorded on her CD "In Two Worlds" released by Innova Records in 2009. In addition, the *Max/MSP* version was featured at the 2008 North American Saxophone Alliance Biennial Conference with a performance by this author.

Figure 13: Susan Fancher Performance at UNCG New Music Festival (2007)

<u>Concert III</u>		
Thursday, October 25, Weatherspoon		
5:30 Reception		
6:00 Bill Fontana		
6:30 Time to go to installation/more Reception		
7:00 Concert		
 <u>Weatherspoon Auditorium:</u>		
In Two Worlds	Susan Fancher, alto saxophone	Morton Subotnick (b. 1933)
 <i>Remarks by Judith Shatin</i>		
Penelope's Song	Susan Fancher, soprano saxophone	Judith Shatin, music and video
 <i>Break</i>		
 <u>Weatherspoon Atrium:</u>		
Energy Drink III	Scott Rawls, viola	Mark Engebretson (b. 1964)
Circleplay	Anthony Taylor, clarinet	Shawn Okpebholo
L'accordeoniste	Eastwind Ensemble Ashley Barret, oboe Kelly Burke, clarinet Steve Stusek, saxophone Michael Burns, bassoon	Alejandro Rutty

¹⁰³ All effects are programmed into the *Max/MSP* patch to trigger at specific points in each "sound event" governed by exact time (in tempo). All sound event triggering is done by the live saxophonist via footpedal.

2.4: THE *MAX/MSP* PATCH

By approximately 1995, Morton Subotnick's interactive computer program *Interactor* had become obsolete with the rise in commercial popularity of the software *Max/MSP*.¹⁰⁴ Developed at IRCAM and maintained by the San Francisco based company, Cycling '74, *Max/MSP* is a graphical environment¹⁰⁵ computer program for interactive music that has become the industry standard for interactive computer music.¹⁰⁶ Miller Puckette initially developed the first version of *Max* in 1986 at IRCAM (Paris, France) as realtime control software for Giuseppe Di Giugno's 4X synthesizer. Puckette used his IRCAM research to create an open-source software based on this version of *Max* called *Pure Data*. Beginning in 1989, David Zicarelli at Cycling '74,¹⁰⁷ translated *Max*¹⁰⁸ into a MIDI software product. In 1997 he then brought Puckette's *Pure Data* audio modules and signal processors into the *Max* environment to create *Max/MSP*, a graphical programming software in which onscreen "objects" are connected via "patchcords" to control the sound output from a computer.¹⁰⁹ *Max/MSP* can now be used to facilitate the reconstruction and performance of early interactive computer compositions whose software, hardware, and technology have become extinct.

In summer 2007, Jeff Heisler and Mark Bunce received permission from Morton Subotnick to attempt the re-creation of *In Two Worlds* by replacing the *Interactor* software with *Max/MSP*. Bunce was able to locate Subotnick's original hardware equipment from the 1990 version of the work. Using a Macintosh (II) Quadra 650

¹⁰⁴ *Interactor* Has not been updated to run on any MAC computer operating systems since 1992.

¹⁰⁵ Computer programming language that lets users manipulate program elements graphically rather than textually (also known as diagrammatic programming)

¹⁰⁶ *Max/MSP website*, <http://www.cycling74.com/products/maxmsp> (accessed December 20, 2008).

¹⁰⁷ Originally part of a company called OPCODE that moved to Cycling '74 in 1999.

¹⁰⁸ *Max* was commercially available in 1990.

¹⁰⁹ EMF Institute, *MAX*, <http://emfinstitute.emf.org/exhibits/max.html> (accessed December 2, 2009).

computer and a Yamaha TX 802 FM tone generator, Heisler and Bunce were able to access the early *Interactor* patch of the concerto in order to record the MIDI sequences¹¹⁰ and create individual sound files.¹¹¹ Once the sound files were created, they were sequentially routed using a “gate object”¹¹² in *Max/MSP* so that the live performer could trigger sounds via footpedal (see Figure 14) in much the same way as Subotnick’s original version.

Figure 14: Sound Event Gate (*In Two Worlds* – 2007)¹¹³

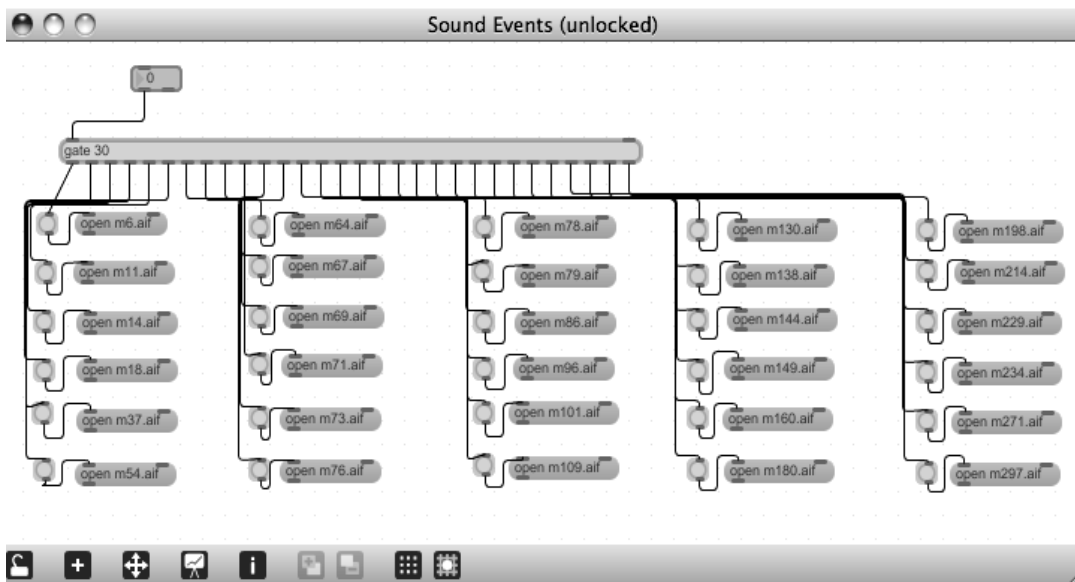

Subotnick specified various effects processing for the acoustic saxophone at specific points during the piece. In the original 1990 version, a microphone sent the saxophone sound to a mixer and then to pre-programmed patches on a Yamaha SPX90 effects processor. *Interactor* then triggered the processor via a MIDI program change

¹¹⁰ Using *Pro Tools* digital audio software.

¹¹¹ Or “sound events” that correspond to the original *Interactor* patch of *In Two Worlds*.

¹¹² “Objects” are small graphical language programs that serve as “building blocks” in a *Max/MSP* patch.

¹¹³ Jeff and Mark Bunce Heisler, “In Two Worlds Max/MSP Patch” (2007-2008).

command. These effects are re-created in *Max/MSP* using digital signal processing (DSP), which include reverb, delay, and pitch shifting. Additionally, since modern computers have dramatically more processing power than Subotnick's original Macintosh II, there is no longer a need for an external effects processor such as the Yamaha SPX90. *Max/MSP* can now create all MIDI sound events and real-time processing effects using the computer's internal processor.

In the 2007 version, the reverb object¹¹⁴ has adjustable parameters of decay time, size, high frequency dampening, and diffusion to accommodate performances in a multitude of different spaces. For *In Two Worlds*, the reverb object (see Figure 15) is preset to the parameters of the original 1990 solo version *Interactor* patch.¹¹⁵

Figure 15: Reverb Object (*In Two Worlds* – 2007)¹¹⁶

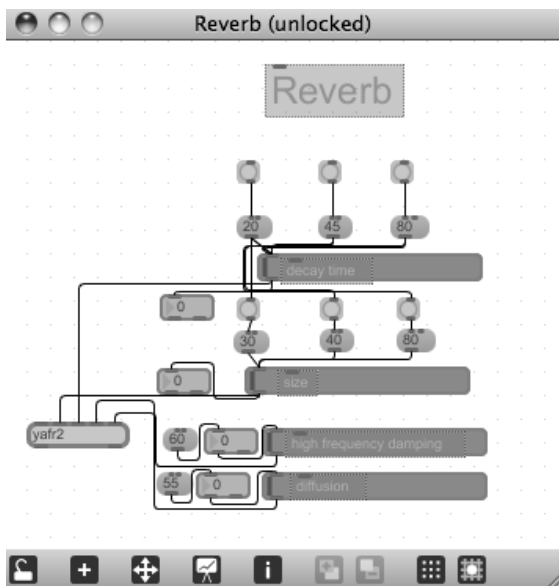

¹¹⁴ Plate reverb, in the style of David Griesinger's "Lexicon reverb." (Randy Jones <rej@zuptech.com)

¹¹⁵ The *Interactor* settings were approximated to replicate the original sound when transferred to *Max/MSP* by Jeff Heisler and Mark Bunce in 2007.

¹¹⁶ Jeff Heisler and Mark Bunce, "In Two Worlds Max/MSP Patch" (2007-2008).

The delay effect was created using the “tapin” and “tapout” objects in *Max/MSP*. The “tapin” object records the live saxophone input via the performer’s microphone and holds the recorded material in a buffer. When specified, the “tapout” object reproduces what the live performer played with the addition of a programmed delay. As seen in Figure 16 below, the preset delays in *In Two Worlds* were created to the parameters of the original 1990 solo version.¹¹⁷

Figure 16: Delay Object (*In Two Worlds* – 2007)¹¹⁸

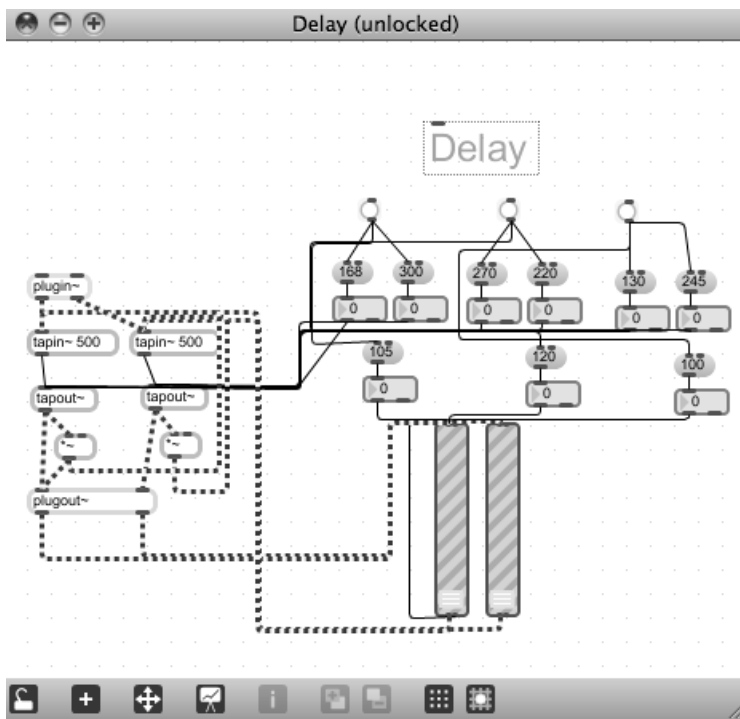

¹¹⁷ The *Interactor* settings were approximated to replicate original sounds when transferred to Max/MSP by Jeff Heisler and Mark Bunce in 2007.

¹¹⁸ Jeff Heisler and Mark Bunce, "In Two Worlds Max/MSP Patch" (2007-2008).

The pitch shifter object uses a fast Fourier transform algorithm¹¹⁹ to detect the pitch being played by the live saxophonist¹²⁰ and then outputs a “shifted” pitch (using the Gizmo~ object) according to the programmed parameters. For *In Two Worlds*, the pitch shifting object outputs two different pitches (right and left channels respectively) relating to the input being detected by the computer.¹²¹ The preset pitch shifters were created to the specifications of the 1990 solo version of *In Two Worlds* (see Figure 17)¹²²

Figure 17: Pitch Shifter Object (*In Two Worlds* – 2007)¹²³

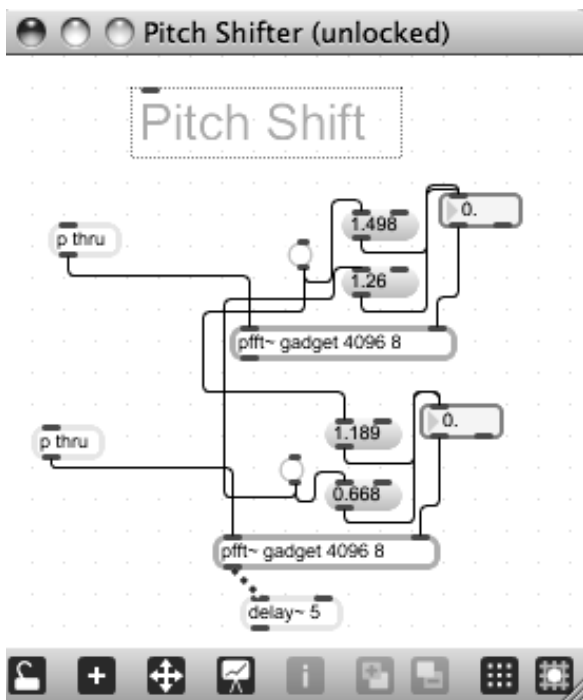

Some of the effects such as reverb, delay, and pitch shifting occur at different points in each sound event. In order to ensure the digital effects processing initiates at

¹¹⁹ FFT: A computationally efficient method of estimating the frequency spectrum of a signal.

¹²⁰ Via microphone.

¹²¹ See Figure 3 for exact pitch shifting specifications.

¹²² The *Interactor* settings were approximated to replicate the original sounds when transferred to *Max/MSP* by Jeff Heisler and Mark Bunce in 2007.

¹²³ Jeff Heisler and Mark Bunce, "In Two Worlds Max/MSP Patch" (2007-2008).

the appropriate moments in the work, delay counters were added to the beginning of each sound event¹²⁴ to postpone the triggering of electronic processing until the exact time it is needed. These delay counters (see Figure 18) act as a metronome and count down in milliseconds (once a sound event is triggered) to suspend the initiation of effects processing until the proper moment in the piece. This allows the live performer to be responsible only for triggering sound events via footpedal.

Figure 18: Sound Event Gate with Delay Triggers (*In Two Worlds* – 2007)¹²⁵

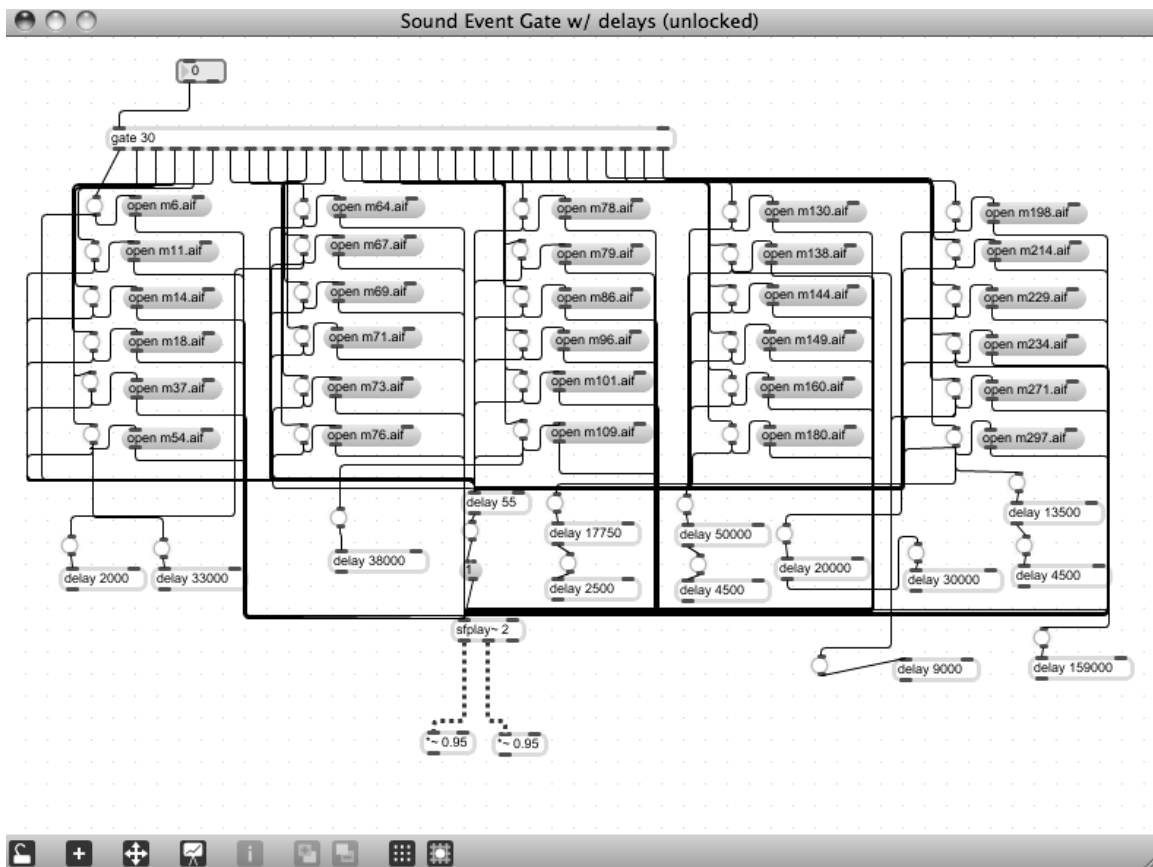

¹²⁴ Triggered by footpedal by live performer.

¹²⁵ Jeff Heisler and Mark Bunce, "In Two Worlds Max/MSP Patch" (2007-2008).

The final step was to connect the sound events and digital effect processors to a mixer for output (along with the live saxophone microphone) to the hall speakers. The home screen mixer for the work (see Figure 19) was created to give volume control of the saxophone input, computer sound events, and effects processing to accommodate acoustics of various size performance halls. While the patch is preset to generic levels to accommodate a medium-sized performance hall, it has manual modification abilities built in to allow more specific volume adjustments when desired. In addition, a rehearsal panel was created (see right side of Figure 19) so the performer could have the option of practicing each sound event separately in preparation for performance.

Figure 19: Home Screen of Max/MSP Version of *In Two Worlds* (2007)¹²⁶

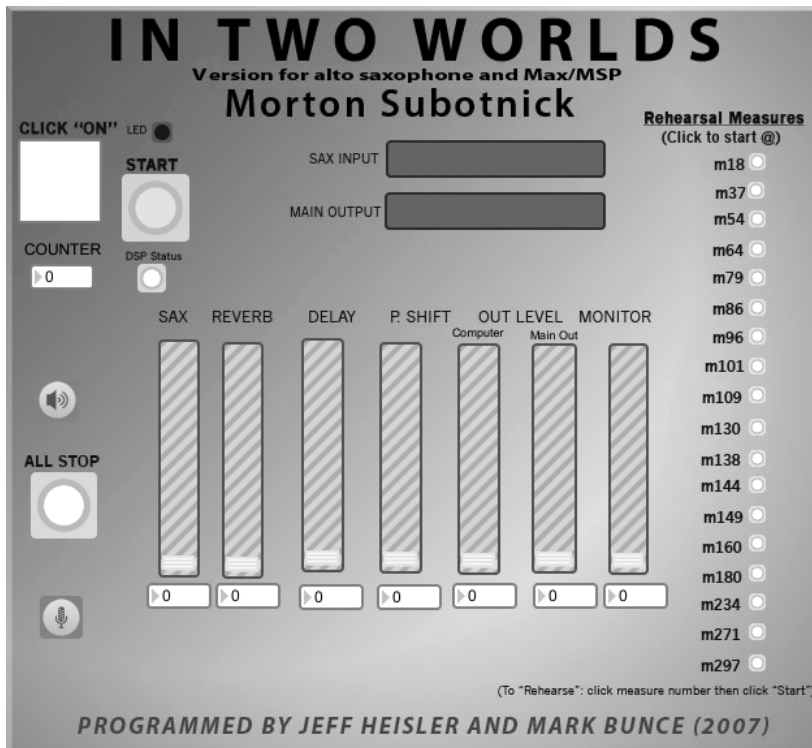

¹²⁶ Jeff Heisler and Mark Bunce, "In Two Worlds Max/MSP Patch" (2007-2008).

The series of effects processing and their implementation into the *Max/MSP* patch of *In Two Worlds* are seen below:

Figure 20: *In Two Worlds* Effects Processing Chart¹²⁷

Section	Measure #	Effects Processing
Alone	1	None - only amplification of solo saxophone
Alone	14	Reverb 1
Rushing	64	Reverb 2
Rushing	67	Delay 1 - Pitch Shifter 1 - Reverb off
Rushing	69	Pitch Shifting off
Rushing	70	Reverb 1 - Delay off
Rushing	73	Reverb 2
Rushing	87	All processing off - only amplification of solo saxophone
Celebration	126	Delay 1
Celebration	142	Reverb 2 - Delay off
Celebration	151	Reverb 3
Cadenza	199	Reverb 2
Alone	234	Reverb 1
Alone / Cadenza	266	Delay 3 - Reverb off
Combat Dance	271	Reverb 2 - Delay off
Combat Dance	280	Delay 2
Combat Dance	293	Pitch Shifter 2 - Delay off
Combat Dance	304	Delay 1 - Pitch Shifting off
Combat Dance	306	Pitch Shifter 2 - Delay off
Combat Dance	308	Reverb 2 - Pitch Shifter off

As already noted (see Figure 20), the 2007 *Max/MSP* version begins with the “Alone” section using only amplification of the saxophone and no processing until m. 14 when reverb is added. The reverb effect adds resonance to the saxophone and helps transform the sound into the illusion of a larger space. This continues until the faster and more agitated “Rushing” section at m. 64 when the reverb setting is changed to the

¹²⁷ Created by Jeff Heisler and Mark Bunce (2007) using the specifications of the 1990 solo version *Interactor* patch to replicate as closely as possible the original electronic processing by the SPX90 in *In Two Worlds*.

largest reverb 2. In m. 67 the reverb is turned off, delay setting 1 is turned on, and pitch shifting 1 is introduced. The combination of delay and pitch shifting effects produce a chaotic effect in the music. The pitch shifter is turned off in m. 69 and the delay setting is changed to reverb in m. 70. Reverb setting 2 begins in m. 73 and creates a complex sound environment by contrasting MIDI timbres with multiple articulations on the saxophone. In m. 87, all processing effects are turned off while the computer and live saxophonist perform virtuosic technical passages. The processing effects do not return until the “Celebration” section in m. 142 when reverb 2 is added. In m. 151, the saxophonist begins a barrage of sixteenth-notes and reverb #3 reinforces the soloist. The large reverb 2 setting returns in m. 199 immediately before the “Cadenza.” This setting remains throughout the first part until the return of the “Alone” section, where reverb 1 setting is reintroduced. A short cadenza-like transition marked “Playfully” features the delay setting 3. “Combat Dance” begins at m. 271, where the delay is turned off and the reverb 2 is initiated. In m. 280, the saxophonist performs the incessant “Celebration” theme and delay 2 is added. This continues until the tremolo in m. 293 where the delay is substituted for the pitch shifting 2 setting. In m. 304, delay 1 is added and during the tremolo in m. 306, pitch shifter 2 returns while the delay is taken off. The pitch shifter is turned off in m. 308 and the piece continues until the end with the electronic processing setting reverb 2.

Heisler and Bunce’s updated 2007 version features reliable real-time effects processing¹²⁸ built into the *Max/MSP* patch, which eliminates the need for external effects processors and FM tone generators. The patch for *In Two Worlds* was designed to

¹²⁸ All effects are programmed into the *Max/MSP* patch to trigger at specific points in each “sound event” governed by exact time (in tempo). All sound event triggering is done by the live saxophonist via footpedal.

re-create, as closely as possible, the exact parameters of the 1990 solo saxophone version.

Thus, Subotnick's historical and musical contribution to the saxophone literature is performable once again using new technology.

CHAPTER III. ANATOMY AND EVOLUTION

3.1: ANATOMY OF *IN TWO WORLDS*

The title *In Two Worlds* refers both to the duality of the media and musical materials. Subotnick's intent was to find a way to blend the performer with responsive technology. Though experimenting with the dichotomy of computer and acoustical music, the composer felt that he had more control of the “expressiveness of the sound”¹²⁹ by using electronics. Subotnick elaborates on this expressiveness by explaining:

John Sampen’s saxophone first sounds like an idealized oboe—then like a boy’s voice and a cello. When he moves into a more rhythmic part of the piece he sounds more percussive. Later, the orchestra plays the same sound but, of course, using different tools. Producing the same sounds in two different ways illustrates what is interesting. A building may look different because new materials have allowed architects to be more expressive. But architects haven’t actually come up with a new idea for living—up in the air, for example. That’s the way most electronic music functions: I don’t create new sounds, but rather combine sounds in new ways. And, of course, because a composer isn’t limited to ten fingers – he can use 15 if he wants—a new excitement and a new way of thinking can emerge.¹³⁰

Subotnick continues to share his rationale behind *In Two Worlds* in an interview with this author:

You have the concerto where the orchestra plays the material and then you have technology that comes out of a boombox (or some other environment) and it is really transformed. There is no question about it. It is very sublime, and important, and serious. When the orchestra plays the very same material and it becomes rock-and-roll with very little change, the sound is all that changes—the medium changes the message radically.¹³¹

¹²⁹ Morton Subotnick, "In Two Worlds - New Mexico Symphony Program Notes," *New Mexico Symphony Program* (New Mexico Symphony, 1988).

¹³⁰ Ibid

¹³¹ Morton Subotnick, interview by Jeff Heisler, *Live Interview with Morton Subotnick Regarding In Two Worlds*, (June 14, 2008).

By presenting the same musical material in both electronic and traditional orchestral “worlds,” Subotnick displays the drastic change that sound can have on the audiences’ perceptions. Thus, he creates two radically different “worlds” with the same musical material.

Morton Subotnick describes the formal structure of *In Two Worlds* as: “Part I is almost entirely electronic, combining the WX7 Wind Controller, Air Drum, and computer with only a few members of the orchestra, while Part II is scored more traditionally for alto saxophone and full orchestra with the electronics returning towards the end of the piece.”¹³² In Part I of the full 1988 orchestral version of *In Two Worlds*, the soloist, performing on the WX7 Wind Controller, executes a multitude of electronic timbres and triggers a complex array of accompanying computer instruments, while the conductor, using the Air Drum in one hand and a normal baton in the other, cues computer instruments with the Air Drum and the orchestra with his traditional baton. Part I is divided into the following sections, played without pause: “Alone”—“Rushing”—“Celebration”—“Cadenza.” In part II, the soloist performs on a traditional alto saxophone, and is accompanied by the full orchestra. The music is a development of Part I, transforming the materials both through the music itself and through the dramatic change in timbre from electronic to traditional instruments. The sections of Part II (also played without pause) are: “Alone”—“Cadenza”—“Alone”—“Lullaby”—“Cadenza”—“Celebration”—“Combat dance 1”—and “Combat dance 2.” The computer part (from Part I) returns in the last section (“Combat Dance 2”), which acts as a coda and combines

¹³² Morton Subotnick, interview by Jeff Heisler, *Live Interview with Morton Subotnick Regarding In Two Worlds*, (June 14, 2008).

the “two worlds” of traditional and electronic sounds for a rousing finale.¹³³ Figure 21 (see below) illustrates how the orchestral version’s formal structure evolved:

Figure 21: Original Formal Sections *In Two Worlds*¹³⁴

Version	Toledo Symphony World Premiere Part II	Electric Symphony World Premiere Full Version	New Mexico Symphony U.S. Premiere Full Version
Premiere	1987	1988	1988
Sections (Form)	Part II: Alone (opening) Cadenza 1 Alone Lullaby Cadenza 2 Celebration Combat Dance 1 Combat Dance 2	Part I: Alone (opening) Rushing Celebration Cadenza 1 Part II: Alone (cello solo) Cadenza 2 Lullaby Cadenza 3 Celebration Combat Dance 1 Combat Dance 2	Part I: Alone (opening) Rushing Celebration Cadenza 1 Part II: Alone (cello solo) Alone (opening) Cadenza 2 Alone Lullaby Cadenza 3 Celebration Combat Dance 1 Combat Dance 2

Each section of *In Two Worlds* has a unique musical characteristic (see Figure 22) and in most instances is heard in both electronic and acoustic “worlds.” In addition, each formal section shares its identity with music from Subotnick’s multimedia piece *Hungers*.¹³⁵

¹³³ Morton Subotnick, "In Two Worlds - New Mexico Symphony Program Notes," *New Mexico Symphony Program* (New Mexico Symphony, 1988).

¹³⁴ Data collected from John Sampen’s archive of *In Two Worlds* scores, recordings, and solo parts.

¹³⁵ In his efforts to sustain a living exclusively through composition, Subotnick need multiple projects and choose to write both works (*In Two Worlds* and *Hungers*) simultaneously. This seems to justify his use of similar musical material in both compositions.

Figure 22: Musical Characteristics of *In Two Worlds*¹³⁶

Section	Tempo	Musical Characteristics
Alone	52–60 bpm	Diatonic: long extended flowing phrases with consonant harmonies. Processing effects: Reverb.
Rushing	80–90 bpm	Disjunct: unsteady short rapid virtuosic phrases with dissonant harmonies. Processing effects: Delay, Pitch Shifting, and Reverb.
Celebration	80–90 bpm	Steady “dance-like” articulated (percussive) rhythmic phrases. Processing effects: Delay and Reverb.
Lullaby	52–60 bpm	Diatonic: Lyrical phrases and simple rhythms with consonant harmonies. No processing effects.
Cadenza	Freely	Soloist only - Senza misura: expansive and virtuosic. Processing effects: Reverb.
Combat Dance	108–112 bpm	Virtuosic: “celebration” rhythmic motive with soaring solo saxophone phrases and dissonant harmonies. Processing effects: Delay, Pitch Shifting, and Reverb. Combat Dance 2 = add electronics (computer) to Part II as coda

¹³⁶ Data collected from John Sampen’s archive of *In Two Worlds* scores, recordings, and solo parts.

The movement “Alone” (see Figure 23) represents the opening of *In Two Worlds* and is marked by long diatonic phrases with consonant accompanying harmonies of the computer (solo version) or orchestra (concerto version) respectively. This section also utilizes electronic effects processing of reverb to give the soloist more spatial presence.

Figure 23: Alone¹³⁷

The image displays a musical score for the piece "Alone" by Morton Subotnick. It consists of three staves of music, all in treble clef. The first staff begins at measure 17 and is marked with a "Ped" (pedal) instruction. The second staff begins at measure 20, and the third staff begins at measure 23. The music is characterized by long, diatonic phrases with consonant harmonies, typical of the opening of *In Two Worlds*. The notation includes various note values, rests, and phrasing slurs.

¹³⁷ Morton Subotnick, "In Two Worlds: Solo Saxophone and Max/MSP Version (Saxophone Part)" (Manuscript, 2007).

“Rushing” (see Figure 24) abruptly interrupts the extended phrases of “Alone” and features agitated, short virtuosic musical fragments as the computer and saxophonist communicate in an unstable, dissonant dialogue. Here, Subotnick utilizes reverb, delay, and pitch shifting effects to intensify this chaotic music.

Figure 24: Rushing¹³⁸

The musical score for "Rushing" consists of six staves of music. The first staff (measures 63-65) is in 4/4 time, marked *ff* and *f*, with a *Ped* marking above measure 64. The second staff (measures 66-69) is in 4/4 time, marked *fp* and *ff*, with a *Ped* marking above measure 67 and a triplet of eighth notes in measure 68. The third staff (measures 70-77) is in 4/4 time, marked *sfz* and *f*, with a *Ped* marking above measure 71 and a triplet of eighth notes in measure 75. The fourth staff (measures 78-80) is in 2/4 time, marked *mf*, with a *Ped* marking above measure 78 and a tempo marking of $\text{♩} = 80$. The fifth staff (measures 81-82) is in 4/4 time, marked *ff*. The sixth staff (measures 83-85) is in 4/4 time, marked with dynamics *p*, *f*, *mp*, *ff*, *pp*, *mf*, *ff*, *pp*, *p*, *mf*, *f*, and *ff*. The final staff (measures 86-88) is in 4/4 time, marked *ff*, with a *Ped* marking above measure 86.

¹³⁸ Morton Subotnick, "In Two Worlds: Solo Saxophone and Max/MSP Version (Saxophone Part)" (Manuscript, 2007).

The “Celebration” motive (see Figure 25) is an incessant, percussive rhythm usually accompanied with reverb and delay electronic processing to intensify the steady articulations of the soloist. The rhythmic motive of this section is heard throughout other portions of *In Two Worlds* and is used as an ostinato during the last movement of the piece (“Combat Dance”).

Figure 25: Celebration¹³⁹

¹³⁹ Morton Subotnick, "In Two Worlds: Solo Saxophone and Max/MSP Version (Saxophone Part)" (Manuscript, 2007).

“Lullaby” (see Figure 26) contains simple diatonic phrases with consonant harmonies and is used only in Part II of Subotnick’s orchestral versions of *In Two Worlds*. The music is without electronic processing effects; the solo alto saxophone is accompanied by the full orchestra creating a purely acoustic musical “world.”

Figure 26: Lullaby¹⁴⁰

The image shows a handwritten musical score for the piece "Lullaby" and "Cadenza 2". The score is written on four staves. The first three staves are labeled "LULLABY" and contain measures 100 through 124. The fourth staff is labeled "CADENZA 2" and contains measures 125 through 126. The score includes various musical notations such as notes, rests, and dynamic markings (e.g., *mp*, *f*). There are also handwritten annotations in blue ink, including "Slow", "Vla.", "Hrn.", "Trumpet", "Palm", "Harp", and "In time (♩=72)". The score is written in a 4/4 time signature.

The concerto contains several “Cadenza” sections in which the work demands virtuosic technique. The electronic processing in these “Cadenza” sections originally featured reverb and pitch shifting; however, in the solo version the pitch shifters were eliminated, leaving reverb as the only sound reinforcement.

¹⁴⁰ Morton Subotnick, "In Two Worlds Orchestral Version Solo Part" (Manuscript, 1988).

In the soloist's score (see Figure 27), there is no indication for processing. All electronic manipulations were programmed into the computer software to trigger at the appropriate moments of the work.

Figure 27: Cadenza¹⁴¹

The image displays a musical score for a cadenza, spanning measures 200 to 221. The score is written in treble clef and features several time signature changes: 3/8, 4/4, 3/4, and 2/4. Dynamic markings include *ppp*, *mp*, and *p*. A 'Ped' (pedal) marking is present in measure 212. The notation includes various note values, rests, and articulation marks.

The full orchestral version of the work utilizes three separate cadenzas and in many cases, saxophonist John Sampen, contributed to the composition of the cadenzas¹⁴² by offering alternative virtuosic passages.

¹⁴¹ Morton Subotnick, "In Two Worlds: Solo Saxophone and Max/MSP Version (Saxophone Part)" (Manuscript, 2007).

Figure 28 (see below) reveals Sampen’s suggestions for fingering, double tonguing, and other timber changes in “Cadenza 2.” All were eventually approved and finalized by the composer in the final revisions.

Figure 28: John Sampen’s Cadenza Suggestions (1987)¹⁴³

The image shows a handwritten musical score for a cadenza. The score is written on multiple staves with various musical notations, including notes, rests, and dynamic markings. Key annotations include:

- Measure 125:** Handwritten '125' in a box, with 'fp' (fortissimo) markings above the notes.
- Measure 128:** Handwritten '128' in a box, with 'stacc' (staccato) and 'f' (forte) markings.
- Measure 129:** Handwritten '129' in a box, with 'perc' (percussion) and 'LH palm' markings.
- Measure 130:** Handwritten '130' in a box, with 'f' (forte) and 'mp' (mezzo-piano) markings.
- Measure 133:** Handwritten '133' in a box, with 'perc' (percussion) and 'addiz' (additive) markings.
- Measure 149:** Handwritten '149' in a box, with 'centr' (center) and 'pizz' (pizzicato) markings.

Other annotations include 'Subotnulo', 'Cadenza 2 (Version 1)', 'No F ke', and 'Behm, Mills'. The score is densely packed with musical notation and handwritten instructions.

¹⁴² See Figure 28 (John Sampen’s suggestions for “Cadenza 2” of *In Two Worlds*).

¹⁴³ John Sampen, "Cadenza 2 suggestions for *In Two Worlds*" (1987).

The rousing “Combat Dance” (see Figure 29) concludes the entire work with two iterations: “Combat Dance 1” and “Combat Dance 2.”

Figure 29: Combat Dance¹⁴⁴

The image displays a musical score for the piece "Combat Dance" by Morton Subotnick, spanning measures 270 to 289. The score is written for a solo saxophone and is presented in a single staff with a treble clef. The key signature is one flat (B-flat major/D minor), and the time signature is 3/4. The tempo is marked as "Ped (♩=108)" and the dynamics are "ff" (fortissimo). The score begins with a series of rapid sixteenth-note runs in measures 270-271, followed by a change in rhythm and melodic contour in measure 272. Measures 276-277 feature a more melodic line with slurs. Measures 280-282 consist of a dense, rhythmic pattern of sixteenth notes. Measures 283-285 show a continuation of this rhythmic pattern with some melodic variation. Measures 286-288 feature a more melodic line with slurs, and measure 289 concludes with a final melodic phrase.

¹⁴⁴ Morton Subotnick, "In Two Worlds: Solo Saxophone and Max/MSP Version (Saxophone Part)" (Manuscript, 2007).

The musical characteristics of these “dance” sections include soaring “superhero-like”¹⁴⁵ saxophone phrases accompanied by the “Celebration” rhythmic motive¹⁴⁶ and dissonant harmonies in the orchestra (see Figure 30). The music for the “Combat Dance” was originally written for a Javanese-inspired dancer in Subotnick’s multimedia dance composition, *Hungers*.¹⁴⁷ Here, the composer projected an oversized video image of the dancer behind the performer to suggest two drastically different visual spaces. This concept is similar to the duality of sonic “worlds” in the saxophone concerto.¹⁴⁸

Figure 30: Combat Dance with “Celebration” Rhythm¹⁴⁹

The image displays a musical score for two sections. The top section, titled "Combat Dance", is a single melodic line in 4/4 time, starting at measure 321. It features a series of eighth and sixteenth notes, with a dynamic marking of *f* (forte) at the beginning. The bottom section, titled "Celebration 'Rhythm'", consists of two staves: a treble clef staff and a bass clef staff, both in 4/4 time. The treble staff begins with a dynamic marking of *f* and contains a rhythmic pattern of eighth notes. The bass staff also begins with a dynamic marking of *f* and contains a similar rhythmic pattern. The score is presented in a standard musical notation style with a key signature of one flat (B-flat).

¹⁴⁵ “Superhero-like” is a term Morton Subotnick used to describe the musical intensity of *Combat Dance*. Also, Subotnick used the term when he signed John Sampen’s score to *In Two Worlds* as: “John, Thanks for a wonderful performance! You are show and a “hero”!! – M.S. (from: Morton Subotnick, “In Two Worlds Orchestral Version Solo Part” (Manuscript, 1987).

¹⁴⁶ See Figure 30 (“Combat Dance” with “Celebration” Rhythm).

¹⁴⁷ Subotnick also referred to *In Two Worlds* as “music conceived for an imaginary ballet with a single dancer on a vast stage.” (from: Morton Subotnick, “In Two Worlds Concert Program - Electric Symphony” *Program: Electric Symphony Orchestra* (London: Electric Symphony Orchestra, January 19, 1988).

¹⁴⁸ Morton Subotnick, interview by Jeff Heisler, *Live Interview with Morton Subotnick Regarding In Two Worlds*, (June 14, 2008).

¹⁴⁹ Morton Subotnick, “In Two Worlds Solo WX7 and Computer Score” (Manuscript, 1988).

The effects processing in “Combat Dance” include a large amount of reverb, delay, and pitch shifting. “Combat Dance 2” acts as the coda of *In Two Worlds* and the computer (MIDI) electronic sounds are added to the orchestral accompaniment to fuse the two sonic “worlds” for the final time.

The formal structure of *In Two Worlds* has been in constant flux as Subotnick undertook extensive revisions of the musical material and technology used to create each subsequent version. However, since Subotnick was using the same music to write *In Two Worlds* and *Hungers* simultaneously, the sections (“Alone,” “Rushing,” “Celebration,” “Lullaby,” “Cadenza,” and “Combat Dance”) remain structurally unchanged. It is only the formal organization that Subotnick revises in the saxophone concerto from 1987–1992.

3.2: EVOLUTION OF *IN TWO WORLDS*

Since the first performance of *In Two Worlds* was incomplete and dependent on emerging technologies, extensive revision of the work was necessary and thus became a critical part of its history. A chronological evolution of *In Two Worlds* is provided in Figure 31.¹⁵⁰

Figure 31: Revisions of *In Two Worlds* (1987–2007)¹⁵¹

Version	Toledo Symphony World Premiere Part II	Electric Symphony World Premiere Full Version	New Mexico Symphony U.S. Premiere Full Version	Solo WX7 Version	Solo Alto Sax Version	Pesaro, Italy WSC Shortened Orchestral Version	Max/MSP Version
Premiere	1987	1988	1988	1988	1990	1992	2007
# of Measures	328	547	612	373	323	350	323
Duration	21:00	33:30	35:00	20:00	18:30	22:00	18:30
Sections (Form)	Part II: Alone (opening) Cadenza 1 Alone Lullaby Cadenza 2 Celebration Combat Dance 1 Combat Dance 2	Part I: Alone (opening) Rushing Celebration Cadenza 1 Part II: Alone (cello solo) Cadenza 2 Lullaby Cadenza 3 Celebration Combat Dance 1 Combat Dance 2	Part I: Alone (opening) Rushing Celebration Cadenza 1 Part II: Alone (cello solo) Alone (opening) Cadenza 2 Alone Lullaby Cadenza 3 Celebration Combat Dance 1 Combat Dance 2	Alone (opening) Rushing Celebration Cadenza Alone Combat Dance	Alone (opening) Rushing Celebration Cadenza Alone Combat Dance	Alone (opening) Rushing Alone Cadenza 1 Lullaby Cadenza 2 Celebration Combat Dance	Alone (opening) Rushing Celebration Cadenza Alone Combat Dance
Technology	<i>Interactor</i> <i>Air Drum</i> Yamaha TX802 Yamaha SPX90	Amplified Orch. <i>Interactor</i> <i>Air Drum</i> <i>WX7 Wind – Controller</i> Yamaha TX802 Yamaha SPX90	<i>Interactor</i> <i>Air Drum</i> <i>WX7 Wind – Controller</i> Yamaha TX802 Yamaha SPX90	<i>Interactor</i> <i>WX7 Wind – Controller</i> Yamaha TX802 Yamaha SPX90	<i>Interactor</i> Yamaha TX802 Yamaha SPX90	<i>Interactor</i> Yamaha TX802 Yamaha SPX90	<i>Max/MSP</i>

As noted in the previous chapter, Subotnick’s original intent was to create a concerto for alto saxophone, Yamaha WX7 Wind Controller, computer, Air Drum and

¹⁵⁰ Evolution of *In Two Worlds* includes revisions in formal structure, technology, and orchestration.

¹⁵¹ Data collected from John Sampen’s archive of *In Two Worlds* scores, recordings, and solo parts.

orchestra. At the time of the premiere, the wind controller used in the concerto was commercially unavailable, thus the first performance of the work¹⁵² consisted of only Part II, which included solo alto saxophone, Air Drum, orchestra, and computer.¹⁵³ Soloist, John Sampen, finally was able to acquire a Yamaha WX7 Wind Controller in December of 1987 and the full orchestral version was premiered with the Electric Symphony in Cambridge, England in January 1988. This version of the work required solo alto saxophone, Yamaha WX7 Wind Controller, computer, Air Drum and amplified orchestra. However, according to Morton Subotnick, the “amplification” of the orchestra was not his original idea, but rather the suggestion of Richard Gonski, conductor of the Electric Symphony.¹⁵⁴ The 1988 Electric Symphony version of *In Two Worlds* has a formal structure consisting of Part I: “Alone”—“Rushing”—“Celebration”—“Cadenza 1” (soloist performing on wind controller) and Part II: “Alone”—“Cadenza 2”—“Lullaby”—“Cadenza 3”—“Celebration”—“Combat Dance 1”—“Combat Dance 2” (soloist performing on alto saxophone).

The formal structure of the 1988 American Premiere marks only a slight revision from that of the Electric Symphony edition. For this version, Subotnick inserts a recapitulation of the opening “Alone” section in Part II after a transitional cello solo. The additional material was inserted so the audience could truly experience the duality of electronic and acoustic mediums with an exact restatement of the material. The original statement featured electronics at the opening of the concerto while the recapitulation drastically changes character by use of traditional instruments. This also strengthened

¹⁵² John Sampen’s 1987 performance with the Toledo Symphony Orchestra.

¹⁵³ Computer (using *Interactor* software) only appears in “Combat Dance 2” (Part II).

¹⁵⁴ Morton Subotnick, interview by Jeff Heisler, *Live Interview with Morton Subotnick Regarding In Two Worlds*, (June 14, 2008).

Subotnick's original idea to make the concerto's "medium the message."¹⁵⁵ As the prominent communications scholar, Marshall McLuhan, famously stated, "The medium *is* the message" because it is the "medium that shapes and controls the scale and form of human association and action."¹⁵⁶ Subotnick explains that his original idea for *In Two Worlds* was to have, ". . . the message inform the medium and the medium inform the message."¹⁵⁷ The composer illustrates this by the drastic difference in soundscape when musical material is performed by electronic versus acoustic mediums. This creates a symbiotic relationship in which the medium influences how the audience perceives the message. As a result, Subotnick's *In Two Worlds* reveals a profound change in aural perception between electronic and acoustic "worlds" and supports McLuhan's iconic thesis.

The 1988 solo wind controller version of *In Two Worlds* marks a radical change in formal structure and concept of the work. Looking to make the piece performable without orchestra, Subotnick created a version of the work for solo wind controller and computer for saxophonist Kenneth Radnofsky. The premiere was included on a concert presentation entitled "The Binary Convergence" at the Massachusetts Institute of Technology's experimental performance facility. Interestingly, for this setting Subotnick drastically recasts the formal structure. Sections include "Alone," "Rushing," and "Celebration" from Part I of the concerto and "Cadenza," "Alone," and "Combat Dance" from Part II. Subotnick eliminated the entire orchestra, the Air Drum, the alto saxophone, and more than fifteen minutes of music from the previous full concerto

¹⁵⁵ Morton Subotnick, interview by Jeff Heisler, *Live Interview with Morton Subotnick Regarding In Two Worlds*, (June 14, 2008).

¹⁵⁶ Marshall McLuhan, *Understanding Media* (New York, New York: McGraw Hill, 1964).

¹⁵⁷ Morton Subotnick, interview by Jeff Heisler, *Live Interview with Morton Subotnick Regarding In Two Worlds*, (June 14, 2008).

version. Most importantly, the work was now exclusively electronic and cast in only “one world.” The original idea of contrasting mediums creating the “message” was temporarily abandoned. In an interview with this author, Subotnick explains that “*In Two Worlds* is broken up into the two parts now and the solo version really is a full piece, but the original idea of the piece isn’t coming across.”¹⁵⁸ When asked if he would prefer the piece performed only in its original orchestration, Subotnick chuckled and responded, “Well it would be nice if you did it [the solo version] and called it “*In One of the Two Worlds*.”¹⁵⁹ At the same time, it could be argued that the duality of sound environments are still evident in the solo version through the careful application of effects processing.¹⁶⁰

The 1990 solo alto saxophone and computer version of *In Two Worlds* is an exact transcription of the 1988 solo wind controller formal structure with only a few minor edits to shorten the length of the piece. His slight reduction involved cutting fifty measures of material in both “Alone” sections. This decision apparently was a response to John Sampen’s suggestion that the work was “a little too long and the audience seems to tune out.”¹⁶¹ In a letter to Morton Subotnick, Sampen gave his approval for this shortened solo version of *In Two Worlds* by stating, “. . . this is a strong and electronically secure version of the piece. I am particularly pleased with the return to the saxophone as the solo voice.”¹⁶²

¹⁵⁸ Morton Subotnick, interview by Jeff Heisler, , *Live Interview with Morton Subotnick Regarding In Two Worlds*, (June 14, 2008).

¹⁵⁹ Ibid

¹⁶⁰ When the solo alto saxophone performs without MIDI accompaniment and effects processing, it represents an acoustic “world.” However, when the solo saxophone is electronically processed using delay or pitch shifting and is accompanied by the MIDI sound events, this would radically change the “message” of this music and symbolize an electronic “world.”

¹⁶¹ John Sampen, "Letter to Morton Subotnick" (February 14, 1991).

¹⁶² Ibid

The solo saxophone version received critical acclaim following John Sampen's 1992 recording, "The Contemporary Saxophone," released by Neuma Records. A review by Linda Dusman, published in the *Computer Music Journal*, called Subotnick's *In Two Worlds* ". . . a concerto for alto saxophone and orchestra, and, in an optional version not presented on this disc, orchestra, the work is a quintessential solo concerto, demanding virtuosity of the soloist . . . with electronic processing [of the saxophone] and interaction with the computer."¹⁶³ An anonymous review in the *Saxophone Journal* also remarked, "The sequenced music of Subotnick is unbelievably exciting, intriguing, sometimes mystifying, and always moving. In some ways the piece could be called a 'Sci-Fi odyssey' for the saxophone containing all the swashuckling adventure that anyone could ever want."¹⁶⁴ These critiques helped give Subotnick's saxophone work significant recognition in the electronic music world.

The final orchestral setting of *In Two Worlds* was premiered in 1992 by John Sampen at the 10th World Saxophone Congress in Pesaro, Italy. Subotnick's adaptation of the work marked a drastic change in technology and musical form as compared with his previous 1988 New Mexico Symphony performance. In the 1992 Italian version, the composer eliminated the wind controller and Air Drum parts, as both instruments had proven unreliable for his compositional needs. The alto saxophone again became the exclusive solo instrument of the concerto. It was combined with the colors of orchestral instruments and the electronic "world" of the computer to retain Subotnick's original concept. This 1992 orchestral version was now as "electronically secure" as the 1990

¹⁶³ Linda Dusman, "Review: The Contemporary Saxophone," *Computer Music Journal* 18, no. 1 (Spring 1994).

¹⁶⁴ "Review: The Contemporary Saxophone," *The Saxophone Journal*, Vol. 18 (November 1993).

solo alto saxophone and computer edition. Both could be reliably performed with accurate footpedal control of the computer.

In addition, many sections that contained the WX7 Wind Controller and Air Drum were eliminated, shortening the length of the work from 35 minutes to 22 minutes. “Celebration” from Part I and “Alone,” “Cadenza 3,” and half of “Combat Dance” from Part II were all deleted. Additionally, the form of the piece was modified to more closely follow the structure of the 1990 solo saxophone and computer version. The formal structure of the currently available concerto version became: “Alone”—“Rushing”—“Alone”—“Cadenza 1”—“Lullaby”—“Cadenza 2”—“Celebration,” and “Combat Dance.”¹⁶⁵ Because the wind controller was eliminated as a solo instrument, Subotnick’s original premise that the “medium is the message” has been compromised. However, one may argue that since the solo alto saxophone performs with and without electronic processing while the computer introduces previous musical material using MIDI sounds (in “Combat Dance”) the audience still hears the transformation of sound from acoustic to electronic mediums. This allows the idea behind *In Two Worlds* to resonate even with drastic modifications to musical form and technology.

Since the premiere of the solo alto saxophone version in 1990, interactive computer technology¹⁶⁶ has improved dramatically. In addition, most of the electronic hardware and software used in late 1980s have become obsolete or extinct over the past twenty years as a result of rapid advancements in computer technology. Subotnick’s *In Two Worlds* was no exception and quickly became “un-performable.” Out-of-date technology such as *Interactor* and the Macintosh II computer were no longer supported

¹⁶⁵ “Combat Dance” is now the only section that uses the computer to perform MIDI playback. The rest of the concerto is solo alto saxophone (with effects processing) and orchestra.

¹⁶⁶ This includes hardware and software.

or produced by the late 1990s. As a result, the piece remained dormant for almost a decade until Jeff Heisler and Mark Bunce created a version of *In Two Worlds* substituting *Max/MSP* for *Interactor* in 2007. Updating the interactive computer software to modern technology allowed this landmark piece to be performed again. The *Max/MSP* version replicated the exact electronic specifications of the 1990 solo alto saxophone /computer version and followed the same musical form with only a change in computer software.¹⁶⁷ Saxophonist Susan Fancher premiered the *Max/MSP* version in 2007 at the University of North Carolina Greensboro New Music Festival. This edition was also presented at the 2007 North American Saxophone Alliance Biennial Conference (University of South Carolina) as performed by this author. In addition, this version was featured on Susan Fancher's CD titled "In Two Worlds" released by Innova Records in 2009.¹⁶⁸ Schott Music is currently publishing Morton Subotnick's recent works, including this *Max/MSP* version of *In Two Worlds*.

The performers of *In Two Worlds* have played an important role in the evolution of the musical material in the work. As noted in the previous chapter, John Sampen often suggested alternative technical passages for the cadenza sections and possible cuts to reduce the length of the piece. Subotnick has employed this practice of seeking technical advice for musical choices throughout the history of *In Two Worlds*. Since this work shares its history with a non-saxophone work (*Hungers*), the composer utilized the expertise of the performer (John Sampen) to create idiomatic musical gestures for the instrument and to help distinguish the concerto as musically independent from the multimedia piece. We see Subotnick's willingness to tailor the music to fit the

¹⁶⁷ *Max/MSP* instead of *Interactor*.

¹⁶⁸ Innova 736 (Recording label of the American Composers Forum).

performer's technique in a letter in which the composer says, "Hi John, take a look at this [saxophone part to *In Two Worlds*] as quickly as possible. Mark the bad trills . . . etc. and cross out the notes you can't, or won't, or refuse, or rather not reach."¹⁶⁹ Subotnick also tells Sampen that there are "some wrong notes—don't worry about them."¹⁷⁰ This revision of the saxophone writing sought to exploit the technical prowess of the performer and the acknowledgement of "unnamed" wrong notes in the part makes it extremely difficult, if not impossible, to identify a "correct" or preferred version of *In Two Worlds*.

Another example of the constant revision of *In Two Worlds* is identified in John Sampen's response to Subotnick's fax (in Figure 32—see Appendix B) when he writes, "I just reviewed this quickly and I am sending pages that have suggestions. The pattern at #134 will be hard to keep repeating, so I have also sent a page of alternate suggestions."¹⁷¹ (See Figure 32 in Appendix B)

The constant revision to the saxophone part ultimately obscured the composer's original intent and thus makes it difficult to identify an authoritative performance edition. There are still many pitch discrepancies in the saxophone part between the concerto and solo versions. However, many of the inconsistencies are insignificant and do not affect the harmonic structure of the work.

Considering, the revision process of resurrecting *In Two Worlds* to modern interactive technology such as *Max/MSP*, a fundamental question may be asked – "Should this piece, or any electronic music, be preserved for future performers?" In order to preserve and access information, a transcription from old to new media is

¹⁶⁹ Morton Subotnick, "Fax Cover Letter to Saxophone Part of *In Two Worlds*" (1990).

¹⁷⁰ John Sampen, "Return Fax of Suggestions to Saxophone Part of *In Two Worlds*" (1990).

¹⁷¹ *Ibid*

necessary, not only because the media is fragile and degradable, but also because the technology to access this information will ultimately become obsolete. Our technological society has fundamentally changed our concept of preservation. If we wish to preserve digital media, the accessing of this information will become increasingly more difficult as technology rapidly advances in the future.¹⁷² Even if there was a way to store digital data permanently, the hardware, and software needed to recover the information will most certainly become obsolete. For example, would one consider accessing original data from World War II if was necessary to use fifty-year-old technology to retrieve it? This situation is the fundamental problem with preserving digital media and more specifically electronic music such as *In Two Worlds*.

According to Su-Shing Chen, author of “The Paradox of Digital Preservation,” “Preserving digital information is plagued by short media life, obsolete hardware and software, slow read times of old media, and defunct Web sites. Herein lies the paradox: We want to maintain digital information intact, but we also want to access this information in a dynamic use context. Finding ways to resolve the tension between the creation context and the use context constitutes an important research challenge.”¹⁷³ This struggle for digital preservation is exactly the purpose for undertaking the restoration and resurrection of Morton Subotnick’s *In Two Worlds*. As technology continues to advance, similar projects will follow to preserve our media and art. Works for saxophone and magnetic tape have often been converted to digital formats such as .mpeg, or .aiff

¹⁷² Paraphrased from: Su-Shing Chen, "The Paradox of Digital Preservation," <http://www.media-matters.net/docs/resources/Digital%20Preservation/ParadoxOfDigitalPreservation.pdf> (accessed January 15, 2010).

¹⁷³ Su-Shing Chen, "The Paradox of Digital Preservation," <http://www.media-matters.net/docs/resources/Digital%20Preservation/ParadoxOfDigitalPreservation.pdf> (accessed January 15, 2010).

computer files. When this technology becomes obsolete, another preservation process will be created to save these artifacts as part of our society.

Of course, this process is not exclusive to music. Government agencies, major corporations, and film studios all convert their “old media” to new digital media for preservation purposes, thus insuring reliable accessibility of important historical information with current technology. The process of revising media will continue until we no longer require the ability or desire to access it. *In Two Worlds* is a modern case study in the rapid decay of media and the steps composers and performers of electronic music must take to preserve their art.

CONCLUSION

In Two Worlds communicates the drastic effects technology can have on art through the duality of electronic and acoustic music. Subotnick explored new sonic environments in settings of similar musical material, revealing how the transformation of familiar music to new sounds could perhaps alter audience perception. *In Two Worlds* has seen several evolutions due to technological deficiencies, performer suggestions, and obsolete media. Throughout the turbulent history of the work, Subotnick's original idea (inspired by McLuhan's iconic thesis) remains unchanged. Even with the revisions of orchestration, technology, and form, the identity of *In Two Worlds* still is evident—the transformation of electronic to acoustic music *is* the “message,” thus revealing its meaning. This also sheds light on the ontological question of “in what state of being is this work performed?” If we look closely at the revisions (both the concerto and solo versions), we notice a polarity of “two worlds” through either electronic (MIDI / effects processing) or acoustic (unaltered saxophone / orchestra) sounds. Even though Subotnick jokingly suggests the solo saxophone version has become *In ONE of Two Worlds*, the duality of sound environments is still evident through his effects processing, albeit in a more limited scope than the concerto version.

During the course of this study we have examined many logistical problems with *In Two Worlds*. Ultimately, one may ask if Subotnick's pioneering work should be preserved for future performers? In order to understand the history and evolution of electronic music, musicians need to experience the past in order to successfully realize the future. This being the case, saxophonists need access to Subotnick's *In Two Worlds* for performance and study.

While the work was restored with the intent to replicate the original 1990 solo version with modern interactive computer technology, future digital media preservation will eventually be necessary to perform *In Two Worlds* when current technology becomes obsolete. Performers should expect continuous technological updates in the future in much the same way that CDs, DVDs, and .mp3s have replaced our old vinyl records and VHS tapes. It will be crucial to maintain the parameters of *In Two Worlds* within the specifications of Subotnick's original version; otherwise the integrity of the work will be lost.

Subotnick has revised his concerto in many ways to replace ill-functioning technology, to modify unsatisfactory formal structure, and to adapt to personal technical preferences of the performers. Consequently, a "preferred" version, or an authoritative performance edition of *In Two Worlds* is difficult or perhaps impossible to identify. The composer suggests that his original concerto version of the work is its purest form and the solo saxophone / computer adaptation should be titled "*In ONE of Two Worlds.*"¹⁷⁴ However, all revisions of the work were constructed with the central idea that "the medium is the message" and music may have drastically different associations when presented in altered sonic "worlds."

The current version of *In Two Worlds* for alto saxophone and *Max/MSP* is a self-sufficient and "technologically reliable" version that is prolonging the existence of this revolutionary work for saxophone and interactive electronics. It is the responsibility of future performers to recognize the impact Subotnick's innovations have made on electronic music and take the necessary steps to preserve this finite medium and sustain

¹⁷⁴ Morton Subotnick, interview by Jeff Heisler, *Live Interview with Morton Subotnick Regarding In Two Worlds*, (June 14, 2008).

the art form. *In Two Worlds* is a byproduct of a rapidly advancing technological society. The saxophone repertoire is enhanced by Morton Subotnick's groundbreaking contribution and is now dependent on future performers to ensure its preservation and place in history.

APPENDIX A. INTERVIEW WITH MORTON SUBOTNICK

SUBOTNICK INTERVIEW (Transcription by Jeff Heisler)

June 17, 2008 - NYC

Jeff Heisler: What were your early musical influences?

Morton Subotnick: Well, I was a clarinetist as a kid and I played clarinet professionally until 1964. I grew up playing clarinet and composing music. I started the clarinet at age seven and I began writing music at about 13–14 years old, so I had the usual Mozart and Brahms. By the time I was in high school I had become enamored with Schoenberg, Bartok, and Charles Ives. Because I was living in Los Angeles, I had access to live performances [of Schoenberg and Ives] and so forth. I began writing 12-tone music my last year of high school [1950–1951].

J.H.: You are considered a pioneer in electronic music. Can you talk about your early influences in electronic music?

M.S.: Well, that was 1957–1958. Electronic music only began in 1955 so there was not very much [at that point]. My interest was in the medium that was just getting started and I had very clear pictures of what I would like to do and what I thought could be done. I never really thought that it would happen as quickly as it did. I was thinking I was going to help get it started, but I had no idea I would be there all the way along. So, it was not an influence; it just was part of what I was doing at the time.

J.H.: Has your perception of electronic music changed over your career?

M.S.: Yes, my perception of course has changed—I can't say it hasn't, but no more than I have changed. I have tried all of these years to do a particular kind of thing. Now, when you say electronic music, what exactly are we talking about? Because, it is such a wide genre. My vision of electronics and technology in music was not what eventually became the academic world of electronic music; this was music on a tape recorder made with computers. My idea really had more to do with what happened in the larger scene of technology and music being joined together and people being able to make music who can't even read music. That was what I was envisioning. It didn't have a lot to do with my own music. It had more to do with seeing the world changing and the fact that maybe I could help join technology and music. Along the way I created my own little niche of using technology in the world of sound and music.

J.H.: How do you see electronic music progressing in the future?

M.S.: Well first of all, I don't see any future—I think what has happened as a result of technology is that our concept of time is changing. Past, present, and future are being redefined radically so that what was past for generations and generations from the beginning of human beings no longer exists. We have everything—we're even talking about someday perhaps even seeing the "big bang." So, when you talk about the past, it's a very different concept. When the question was asked (and you are still asking it) what you are really saying is, "What is going to replace what is now?" But, *now* won't be replaced. Instead of moving forward or moving in a direction, what we are getting are parallel things—it's more like a flower blossoming. The change, as we move [into the

future] is that there are parallel things that may start at any given moment, and that will be the future. It will be many more things, but no replacement of any thing. So, it's a very different concept of the future. The future of Mozart will still be in the future, whatever that is. So now, if there are "raves" going on, there probably will still be "raves" going on [in the future], but there will also be something that we haven't thought of going on along side of it. Given that, the future is not the replacement of singularities, but rather a density of multiplicities. The problem in the future (and we are already faced with this now) is what to do with multiplicity because nothing disappears. So, as a result of that we are really stuck. If we have a problem now, imagine what that problem is going to be down the line. If you were going to ask me what the food supply is going to be in the future, then you could talk about replacement, but when we are talking about human creation and things like that, I don't think there is a replacement for it.

J.H.: Could you describe the background in the commissioning of *In Two Worlds*?

M.S.: Well first of all, *In Two Worlds* was written around 1984, but the process actually started a little before because, at that particular point in time, I was relocating my home to Pecos, New Mexico. I was making the decision to leave CalArts and make a living at what I did [as a composer]. It was very inexpensive to live in Pecos, New Mexico. I was writing a multimedia piece called *Hungers* at the same time that I received the commission for *In Two Worlds* and I merged the writing of the two pieces for expedience sake. I could not possibly write two different pieces within the necessary time period of two years. In order to make a living at it, I could not just say no and not take the commission. I really had to do it. It was actually having to do this that caused me to go

back part time to CalArts, because I couldn't see myself continuing that kind of output. So, in the multimedia piece called *Hungers* and the concerto *In Two Worlds*, there are whole sections that go back and forth between the two pieces. They co-existed. When you look historically, you will see that almost any composer trying to work exclusively from writing music, you will find this same back and forth process. I didn't realize that at the time, and I decided that I didn't want to do that [living only from composing] so I stopped. As a result, these two pieces are linked together.

Secondly, the idea of *In Two Worlds* was to create (and I still think this is true) the medium, as Marshall McLuhan had said—the medium *IS* the message. The message informs the medium and the medium informs the message. I realized that one of the problems that I had at that point, trying to define technology and art, was that I couldn't write a piece without technology because the message for technology didn't lend itself to the other—it became transformed. So I decided to write a piece to deal with that issue. You have the concerto where the orchestra plays the material and then you have technology that comes out of a boombox (or some other environment) and it is really transformed. There is no question about it. It is very sublime, and important, and serious. When the orchestra plays the very same material and it becomes rock-and-roll with very little change, the sound is all that changes—the medium changes the message radically. And the version that you are doing [the solo version] has no orchestra in it, so it's all that one thing.

J.H.: Could you explain the history and concept of the sections in *In Two Worlds*?

M.S.: They come from the multimedia thing [*Hungers*]¹—there was a dancer in it. That music was used in a section of the multimedia piece called “Combat Dance” for a Javanese female dancer that I choreographed. She was using traditional gestures with non-traditional choreography and she was “blown up.” This is a very similar concept (to *In Two Worlds*); she was “blown up” really big! And while she was dancing, you saw a huge version of tiny parts of her body (her fingers and things like that). It was all sort of a MIDI orchestra and this became the music for the saxophone part.

J.H.: Does the same go for the sections “Alone” and “Lullaby?”

M.S.: They were jointly written, so I used the same names. I wasn’t hiding the fact—I used the same names in both pieces. The media piece had sections that were purely visual. The saxophone piece comes from most of the forefront sections of the media piece.

J.H.: Could you discuss some of the technology that was introduced in the first version of *In Two Worlds* such as Air Drums and wind controller?

M.S.: Yes, they were experimental at the time. I later had the same technology turned into a MIDI baton, which was included in a piece performed in Carnegie Hall. The conductor used the baton and the technology looked at [or sensed] all the directions of the wrist. This instrument [Air Drum] was made by Palmtree Instruments. A few people had it, and it never became well known, but I worked with them and they tuned it for me. As for the wind controller, Yamaha had given me some money for the development of the

instrument. It was a small amount, but it was enough for me to deal with it. In exchange, I said they could not have anything, they couldn't use my name, they couldn't do anything and they said "that's fine." They didn't have any ownership of it [my work and experiments], but they would like to just be able to keep in contact and come in and see what I was doing and they would be happy to show me what they were doing. So they brought a contingent of engineers from Japan to visit me in Pecos. With them they brought the original wind controller, which at the time, was a phenomenal saxophone. It had everything—almost too much. This was around the early 1980s, I don't know the exact year. They gave me a prototype to use. The problem was that almost no one could play it—the instrument was too complicated. The thumb part [octave keys] was probably the worst because you would barely touch it and it would go up two octaves. So, if you were used to a saxophone, you just couldn't do it. It was too hard, so they made a simpler version. John [Sampen] did a good job with it, but no one else was going to play it. I think if I'm not mistaken, the original concerto had a regular saxophone in it. So, I translated it back to saxophone using the processing (the DSP) and that is the way it ended up. But, at first, the idea was to use it [the wind controller]. The idea was nice, but I found that it was not satisfying in that one didn't need a saxophone player, a keyboard player could do it. So, I decided that it was a nice idea that wasn't a nice idea. And I like the saxophone much better because you really know the person is playing—and that's important.

J.H.: The wind controller was viewed by many as the wind player's answer to the electronic synthesizer. While still somewhat in the public view, the wind controller today has lost much of its promise and charm. What happened to this technology during our so-called technological age?

M.S.: Well, I think it is an ill-conceived notion. First of all, you learn a saxophone, or any instrument, and it becomes part of your nervous system and you don't really think about what you are doing—you just do it. And you cannot do that on a new instrument. You can learn it, and you can learn to play some things, but you will never be able to [really] do it. So, the idea of the wind controller was a good one in that they really tried to make it like a saxophone and you could transfer your technique over to it. If you are in the studios and you are doing music for a film where you don't see the person play and you want to pay less money, you might have that "wind controlling" person do things you couldn't on the keyboard and you could make crescendos and do all of those things easier than you can do with the [keyboard] wheel and maybe be more effective. But, as a concert instrument, it really doesn't make it. Since you are doing everything you do well anyway, you might as well use what you do. If you can't tell that you are doing it, you might as well play keyboard. This is an extremely interesting issue and in many ways pinpoints some of the major issues we have with technology and performance. So, I think eventually that it isn't going to work. It will stay there in the synthesizer domain—wherever that makes sense for it to be.

J.H.: The initial versions of the piece had many technologies such as the interactive batons, wind controllers, and the Electric Symphony. Was the reduction of the technology to what we have now [in *In Two Worlds*] a product of the time it was written?

M.S.: Well, the Electric Symphony wasn't something that we thought of; it was just an amplified orchestra. I would love for the piece to be performed in its orchestral setting. It was only done a few times in the original form. I don't care about the wind controller but I prefer the original orchestration. The New Mexico Symphony and the Italian performance were the two purest performances where you had an orchestra and it was sensational—it was great! It was a big piece that way, but it really works. I guess maybe someday it will go back to that—I don't know. It's broken up into the two parts now and the solo saxophone version is a full piece, but the whole idea of the piece isn't coming across.

J.H.: So, you would prefer that *In Two Worlds* would be performed in the original orchestration?

M.S.: Well it would be nice if you did it [the solo saxophone version] and called it *In One of the Two Worlds* (Subotnick laughs)

J.H.: Can you discuss your role and your use of *Interactor*?

M.S.: Well, *Interactor* was what Yamaha was giving me some money to develop and *Max* [*MSP*] hadn't come into being yet. In fact I was brought to MIT as an artist-in-residence in the 1980s and my goals were: a) to see if I had the aptitude to work with the

more complex technology than the analog stuff and b) to see if I could create or find a way to create with a small computer some kind of software that would allow performers to interact directly with the computer system—because there was none at the time. That is why I called it *Interactor*. I found out that yes, I did have the aptitude because in three months I actually created it. But, it was a prototype that didn't work in real time because not only was the computer small but the stuff I was working on at MIT was in such a raw state that I could only prove it would work, but I couldn't actually use it. That's when *Max* was being written. Miller Puckett was there [at MIT] as a graduate student and we shared experiences. It wasn't *Max* at that point, he was translating something else, but we won't go into that. But, it became *Max* over the years. Yamaha offered to give me money to hire someone to do the programming with the algorithms I created at MIT so I hired a student at CalArts to work for me—Marc Coniglio, and that's how he got started. *Isadora* and that stuff that he's made came out of that whole thing. *Interactor* existed for a while, and then I didn't continue it and Coniglio went on to *Isadora*, and *Max* had come out so it really wasn't necessary as a thing to continue. But, that is how it got started.

J.H.: Can you discuss your revision process when it comes to the different versions of *In Two Worlds*?

M.S.: I didn't actually make many changes there. You mean the solo saxophone version versus the concerto? I think it was pretty much the same as it was written. I had to change it when I moved to the saxophone from the wind controller. But, that wasn't a major change; I don't remember exactly what I had to do. I personally played the saxophone so I knew the instrument and it wasn't a big deal for me to deal with it. But, I

am not quite sure—there really wasn't much of a process involved in the solo version because there always was a solo version in the concerto [version]. I don't really remember, because you had to play the saxophone when you played the wind controller part. That was one of the reasons that I really didn't care about the wind controller because I was really writing a saxophone part.

J.H.: What about the discrepancies in length of the different versions—comparing the solo version to the concerto version?

M.S.: Did it go longer?

J.H.: It started as a 35-minute concerto and now it exists as a 17-minute solo sax and computer version.

M.S.: Right, but the solo version played much of the same music and then the orchestra joined in. The “Combat Dance” for instance exists in both versions; it wasn't one or the other. So, I think the solo version became longer because I probably joined the orchestra earlier on in the work while the solo version was going, but I don't remember how I did that actually, I haven't looked at the score. You probably know better than I do at this point. There wasn't a big revision—it basically was a little fine tuning, just pulling the solo part out. It was intended to be two complete stand alone experiences—one was serious and one was rock-and-roll. So, I don't think there was a big switch that went on there.

J.H.: Can you discuss how you organized the piece [*In Two Worlds*] compositionally in terms of pitch material, rhythms, motives, and color?

M.S.: Do you know *The Key to Songs*? Well, that was written around the same time, maybe a little earlier. Right around that time, there were a series of five or six pieces I wrote over a period of about seven years or so. Harmonically, I formed all of the vertical material into sort of a row of fundamentals. Then I chose every note from where the harmonic occurred. This resulted in things ringing and really sounding. So, everything is in its place. Melodically, I created lines with the vertical harmony in place, like a big chorale. I could pick any of the notes to make melodies. The melodic material is all based on what section I was in. I could make the “Lullaby” melody with the notes that existed in that “world.” Rhythmically, I made these cells of rhythms—they were always long canons at the unison. So, I would take a group of three—like if the unit was sixteenth notes, I would have 3, 5, 7, 11, and 13 note cells. And then I would interpolate rests into these cells to break up the rhythms. Out of those, I would join them together to what I would consider a “rhythmic melody.” Then the rhythmic melody would be combined to the melodic melody in various ways to form long cells of material. By starting a whole series of instruments on these cells of material at different times, the material would start to go out of phase to create complex rhythms and complex melodic material. Then I would fine-tune that; I mean if I didn’t like it, I would go back and restructure it. I actually spewed it quickly, but I spent months re-working and deciding if it was going to work. It doesn’t sound in any way like it has hard core stuff underneath it, but in order to get the kind of flow I wanted and to get some sense of power and

strength, it needed some sort of rigor. But, I didn't want the rigor to come from anywhere else. That's how all of those pieces were done at the time.

J.H.: Are you writing any new saxophone pieces?

M.S.: Right now? Well, I just finished a big piano piece that is being frequently performed right now—*The Other Piano* and then a new one that will be premiered in August [2008] here in Martha's Vineyard for clarinet, violin, and piano with no electronics. I'm not using processing in it. This is only a 14–15 minute piece, but I think I am going to expand it to a 40 minute piece, it feels like it could use it. I just heard the piece for the first time in rehearsal and it sounds really nice.

J.H.: Thank you, I really appreciate your time.

M.S.: You're very welcome.

APPENDIX B: PHOTOS AND LETTERS

PHOTOS:¹⁷⁵

1967 - Morton Subotnick (MS) working on *Silver Apples of the Moon* in his Bleeker Street studio.



1958 - Mills Chamber Players (MS, clarinet; Bonnie Hampton, cello; Naomi Sparrow, piano).



¹⁷⁵ All photos and captions from Morton Subotnick's website - Morton Subotnick, "Biography," *Morton Subotnick Biography*, December 15, 2008, <http://www.mortonsubotnick.com/about.html> (accessed December 15, 2008).

1963 - San Francisco Tape Music Center (SFTMC) crew (left to right): Tony Martin, Bill McGinnis, Ramon Sender, Pauline Oliveros, and MS (seated)



1994 - Demonstration of *Interactor* for Yamaha at Cal Arts. Seated is Mark Coniglio, standing next to Morton Subotnick is David Rosenboom.



Morton Subotnick at IRCAM (1979-1981)



Morton Subotnick AWARDS:

- Guggenheim Fellowship
- Rockefeller Grants (3)
- Meet the Composer (2)
- American Academy of Arts and Letters Composer Award
- Brandies Award
- Deutscher Akademischer Austauschdienst Kunsterprogramm (DAAD), Composer in Residence in Berlin
- Lifetime Achievement Award (SEAMUS at Dartmouth)
- ASCAP: John Cage Award
- ACO: Lifetime Achievement
- Honorary Doctorate from the California Institute of the Arts

Figure 32: Fax from John Sampen to Morton Subotnick with Suggestion to 1990 Solo Saxophon Part (Pages 1 – 5)¹⁷⁶



Bowling Green State University

College of Musical Art
Bowling Green, Ohio 43403
(419) 372-2181
Cable: BGSUC

FACSIMILE MESSAGE

24 Hour Fax Line 419/372-2938

To: Name Morton Subotnick
 Company _____
 Cover Page Plus 5 Total Number of Pages 6

Fr: Name John Sampen
 Date 11/3/90 Time _____

Subject: Morton - I just reviewed this quickly and am sending pages that have suggestions. The pattern at #134 will be hard to keep repeating, so I have also sent a page of alternate suggestions. Call me today at 419/372-2498 if problems.

PS - Marilyn wants to know if you would do a one hour judging session while in BG (extra \$50 honorarium). Best Wishes - JS

If you are having problems or need to confirm, please call 419/372-2181. Thank You.

¹⁷⁶ John Sampen, "Return Fax of Suggestions to Saxophone Part of In Two Worlds" (1990).

Sampen / Subotnick Fax (Page 2)

-30-90 FRI 15:39 La Barbara Subotnick 5859842566 P. 02

looking at *Some very notes! don't worry about them!* dec 5

alto sax 1 2 3 4 5 6 7 8 9 10 11 12 13 14 15 16 17 18 19 20 21 22 23 24 25 26 27 28 29 30 31 32 33 34 35 36 37 38 39 40 41 42 43 44 45 46 47 48 49 50 51 52 53 54 55 56 57 58 59 60 61 62 63 64 65 66 67 68 69 70 71 72 73 74 75 76 77 78 79 80 81 82 83 84 85 86 87 88 89 90 91 92 93 94 95 96 97 98 99 100 101 102 103 104 105 106 107 108 109 110 111

The image shows a handwritten musical score for an alto saxophone. The score is written on ten staves, numbered 1 through 111. The notation includes various musical symbols such as notes, rests, and dynamic markings like *ppp* and *pp*. There are several handwritten annotations in black ink, including circled notes, arrows, and the phrase "Some very notes! don't worry about them!" written across the top. A circled area around measure 12 contains the letters "G4". Another circled area around measure 100 contains the letters "G4". The score is on a page that appears to be a scan of a document, with some background noise and a date stamp at the top: "-30-90 FRI 15:39 La Barbara Subotnick 5859842566 P. 02".

Sampen / Subotnick Fax (Page 3)

V-30-90 FRI 15:39 La Barbara Subotnick 5059842566 P. 02

looking at

alto [transposed]

112 113 114

115 116 117 118

119 120 *awkward note* 121

122

124 125 126

127 128 129

130 131 132 133 134 *repeated pattern a problem*

135 136 137

138 139

140 141 142 143 144

145

Repeated Pattern

146 147 148 149 150

151 152 153

Tricky part but I think ok w/ practice

Sampen / Subotnick Fax (Page 4)

p6

or Break-up pattern - eg

For measure (134) and (146)

The written patterns will be very difficult to play at tempo (.1 = 92)

Sampen / Subotnick Fax (Page 5)

-30-90 FRI 15:40 La Barbara Subotnick 5059842566 P. 05

king at alto [transposed] dec 90

214 217 218 #

214 215 216 217 218 219 220 221 222 223

224 226 227 228 229 230 231 232 233

234 235 236

237 238 239 240

241 242 243 244 245 246 247 248

246 246 247 248 249 250 251 #

253 254 255 256 257 258

259 260 261 262 263 264 265 266

267 268 269 270 271 272 273

274 275 276 277 278 279 280 281 282 Alone 283

284 285 286 287 288 289

4

Figure 33: E-mail to Susan Fancher from Jeff Heisler Regarding Dynamics in *In Two Worlds*

From: Jeff Heisler <heislej@gmail.com>
Subject: Re: dynamics?
Date: May 13, 2008 6:27:11 PM EDT
To: fanch@earthlink.net



Susan,

So very sorry, I forgot to get Sampen's part and give you the dynamics. These are Dr. Sampen's suggestions, written into his performance part in pencil... so, I don't know if these were discussed specifically with Mort or not, but they do follow what he recorded (circa 1992). Many of his suggestions might be a little redundant and will probably be achieved using natural musical instincts.

Here they are...

measure 5 - add crescendo / diminuendo
 measure 7 - add crescendo to measure 8
 measure 17 - add p (piano) at sax entrance at end of bar
 measure 54 - add p (piano) at sax entrance
 measure 58 - 60 add crescendo to f (forte) in measure 61
 measure 77 - add crescendo after fp
 measure 86 - add mf at beginning of saxophone 32nd's
 measure 88 - add f (forte)
 measure 100 - add crescendo to ff at end of bar
 measure 101 - add f (forte)
 measure 108 - add crescendo to ff at end of bar
 measure 110 - add f (forte)
 measure 136 - add fp with crescendo
 measure 160 - add ff
 measure 161 - add mf on 1/2 beat of bar
 measure 165 - add fp with crescendo
 measure 232 - 233 add diminuendo
 measure 234 - add mp
 measure 264 - 265 add diminuendo to p
 measure 271 - add f (forte)
 measure 280 - add mf
 measure 284 - add f (forte)
 measure 289 - add diminuendo to mf
 measure 293 - 294 add crescendo
 measure 296 - add crescendo for beats 2 and 3
 measure 297 - add ff
 measure 304 - add f (forte)
 measure 306 - add crescendo / diminuendo
 measure 307 - add f (forte)
 measure 311 - add ff on beat 4
 add crescendo over last 2 bars

Please keep me apprised with what Mort and Jacob say.

I hope this helps... let me know if you need any further clarification. Good luck with your recording, I can't wait to hear it.

Best wishes,
 -jeff

Jeff Heisler
 DMA Candidate in Contemporary Music
 BGSU Saxophone Teaching Assistant
heislej@bgsu.edu

<http://mustec.bgsu.edu/~jheisler/>

On May 13, 2008, at 11:09 AM, Susan Fancher wrote:

Figure 34: E-mail to Subotnick from Jeff Heisler Regarding 2007 Revision

From: Jeff Heisler <heislej@gmail.com>
Subject: Re: In Two Worlds
Date: April 22, 2008 1:38:32 PM EDT
To: Morton Subotnick <morts@creatingmusic.com>
Cc: Norman Ryan <Norman.Ryan@eamdlc.com>



Morton,

The end of June would be perfect to meet... would sometime between June 21st - 29th work? (I am leaving NYC on June 30th)

As for the sax part that Susan Fancher sent me... the only typo's I have come across are as follows:

measure 6: downbeat low C should be omitted; originally a "trigger" for the wind controller (not to be played) - only a pedal indication should be on downbeat.

measure 93: downbeat is a F (not a G)

measure 96: downbeat is a E (not a F)

measure 101: Eb in beat 2 sixteenth notes (not E nat)

measure 123: too many notes in beat 2; should only be 4 - 32nd notes c, g, c, f (ascending) (no 4th g) - add a dot (.) to sixteenth rest on beat 2.

measure 267: B natural at the end of beat 2 should be Bb (not B natural)

measure 295: beats 2 and 3 should all be low C's (not D's) and the first 2 32nd notes of beat 4 should also be C's (not D's)

Let me know if any of these observations are incorrect. I am comparing the new version from the score I received from Dr. Sampen. (circa 1993) and his recording of the work on the "contemporary saxophone" CD.

I hope this helps... please let me know if late June (21 - 29) work for you in NYC.

Thanks,
-jeff heisler

Jeff Heisler
 DMA Candidate in Contemporary Music
 BGSU Saxophone Teaching Assistant
heislej@bgsu.edu

<http://mustec.bgsu.edu/~jheisler/>

On Apr 22, 2008, at 12:45 PM, Morton Subotnick wrote:

yes, of course...i would be happy to see you.....when do you start?...i will be gone a lot of May...first week of June...will be gone and have a premiere at the end of Aug...so, best time would be late June thru July....i am ccing your email to Norman Ryan at schott...i am sure he will be happy to know that the sax piece works.....did you see any typos or other mistakes that i should know about?

Best,
Mort

NY
 25 Minetta Lane #4B
 NY, NY 10012

morts@creatingmusic.com

REFERENCES

- Ballora, Mark. "IRCAM." *IRCAM History*.
<http://www.music.psu.edu/Faculty%20Pages/Ballora/INART55/IRCAM.html>
 (accessed December 20, 2008).
- Chen, Su-Shing. "The Paradox of Digital Preservation." <http://www.media-matters.net/docs/resources/Digital%20Preservation/ParadoxOfDigitalPreservation.pdf> (accessed January 15, 2010).
- Dusman, Linda. "Review: The Contemporary Saxophone." *Computer Music Journal* 18, no. 1 (Spring 1994): 88–90.
- EMF Institute. "MAX." *MAX*. <http://emfinstitute.emf.org/exhibits/max.html> (accessed December 2, 2009).
- Fancher, Susan. "Program Notes for "In Two Worlds." *innova records*. September 24, 2009. <http://www.innova.mu/notes/736.htm> (accessed September 24, 2009).
- Forest, Peter. "Buchla: 100 Modular Synthesizer." *Synthmuseum.com*.
<http://www.synthmuseum.com/buchla/buc100mods.html> (accessed September 16, 2009).
- Gagne, Cole. "SOUNDPIECES 2 Interviews With American Composers." *The Scarecrow Press*, 1993.
- Heisler, Jeff, and Mark Bunce. "In Two Worlds Max/MSP Patch." 2007—2008.
- "John Sampen Performance Contract." *Subotnick: In Two Worlds*. New Mexico Symphony Orchestra. May 29, 1987.
- Mandes, John. "N.M. Composer's 'In Two Worlds' is Jarring Concerto." *Albuquerque Tribune*, March 12, 1988.
- Max/MSP website*. <http://www.cycling74.com/products/maxmsp> (accessed December 20, 2008).
- Maycock, Robert. "Electrical Overkill." *The Independent*, January 21, 1988.
- McDonald, Susan. "Sampen to introduce New Saxophone." *Monitor: Bowling Green State University*, January 11, 1988.
- McLuhan, Marshall. *Understanding Media*. New York, New York: McGraw Hill, 1964.

- Nelson, Boris. "New Music: The Future is Now." *Toledo Blade*, January 24, 1988.
- . "Program of Classics Provides Fun Evening." *Toledo Blade*, October 17, 1987.
- Noble, David. "Instruments Old and New Square Off in Concerto." *Albuquerque Journal*, March 9, 1988.
- . "Premiere Work Adds To Electric Concert." *Albuquerque Journal*, March 13, 1988.
- O'Riordan, Kirk. "William Albright's Sonata for Alto Saxophone and Piano: A Study in Stylistic Contrast." DMA diss., Arizona State University, August 2003.
- Radnofsky, Kenneth, e-mail conversation with Jeff Heisler. *Subotnick: In Two Worlds Commission* (July 20, 2009).
- Richards, Denby. "Name In Lights." *Ham and Hi - London*, January 29, 1988.
- Roads, Curtis. "Interview with Morton Subotnick." *Computer Music Journal*, Vol. 12 (March 1988): 9–18.
- , and John Strawn. *Foundations of Computer Music*. Cambridge, MA: MIT Press, 1985.
- Rowe, Robert. *Machine Musicanship*. Cambridge, MA: MIT Press, 2001.
- Sampen, John. "Cadenza 2 suggestions for In Two Worlds." 1987.
- . "Letter to Morton Subotnick." February 14, 1991.
- . "Letter to Morton Subotnick 1986." November 30, 1986.
- . "Letter to National Endowment of the Arts." March 18, 1988.
- . "Letter to Neil Stulberg (New Mexico Symphony)." July 31, 1986.
- , interview by Jeff Heisler. *Regarding In Two Worlds* (December 1, 2009).
- . "Return Fax of Suggestions to Saxophone Part of In Two Worlds." 1990.
- . "Letter to Toledo Symphony Regarding Subotnick." September 24, 1984.

- Subotnick, Morton. "Biography." *Morton Subotnick Biography*.
<http://www.mortonsubotnick.com/about.html> (accessed December 15, 2008).
- . "Fax Cover Letter to Saxophone Part of In Two Worlds." 1990.
- . "Hungers." 1988. http://90.146.8.18/en/archiv_files/19881/E1988_065.pdf
 (accessed November 11, 2009).
- . "In Two Worlds - New Mexico Symphony Program Notes." *New Mexico Symphony Program*. New Mexico Symphony, 1988.
- . "In Two Worlds Concert Program: Electric Symphony." *Program: Electric Symphony Orchestra*. London: Electric Symphony Orchestra, January 19, 1988.
- . "In Two Worlds Concert Program: Toledo Symphony." *Program: Toledo Symphony Orchestra*. Toledo, OH: Toledo Symphony Orchestra, October 16, 1987.
- . "In Two Worlds Concert Program." John Sampen at the International Computer Music Conference, November 2, 1989.
- . "In Two Worlds Orchestral Version Solo Part." Manuscript, 1988.
- . "In Two Worlds." 1988 Concerto Version: Full Score, European American Music Corporation, 1987.
- . "In Two Worlds." Solo Version 1B for WX7 and Computer, April 1988.
- . "In Two Worlds Solo WX7 and Computer Score." Manuscript, 1988.
- . "In Two Worlds." Solo Version 1.5 for alto saxophone and computer, December, 1990.
- . "In Two Worlds." Solo Version 1.7 for alto saxophone and computer, February 1992.
- . "In Two Worlds." 1992 Italy Orchestra Version: Full Score for alto saxophone, computer and orchestra, August 1992.
- . "In Two Worlds." Solo Version 2.0 for alto saxophone and computer, 1994.
- . "In Two Worlds: Solo Saxophone and Max/MSP Version (Saxophone Part: Computer Manuscript by Susan Fancher)." Manuscript, 2007/08.
- , and Marc Coniglio "*Interactor: Computer Software*." 1987.

- , and Marc Coniglio "In Two Worlds." *Interactor Patch*, 1987–1992.
- , interview by Curtis Roads. *Interview with Morton Subotnick Computer Music Journal*, Vol. 12, (March 1, 1988): 9–18.
- , interview by Jeff Heisler. *Live Interview with Morton Subotnick Regarding In Two Worlds* (June 14, 2008).
- , interview by Jeff Heisler. *Phone Interview* (as paraphrased by author) (September 21, 2009).
- . *Silver Apples of the Moon*. Program Notes. Nonesuch: H-71174, 1967.
- Tenth World Saxophone Congress Program*. "9:15 p.m. Concert - September 6, 1992." Pesaro, 1992.
- Yamaha Corporation. "WX7 Wind Controller User Manual." Hamamatsu: Yamaha, 1987.
- Zaliouk, Yuval. "Letter to the National Endowment of the Arts." Toledo, OH, August 27, 1984.
- Unknown. "BG Prof To Debut Electric Sax." *Sentinel-Tribune*, January 13, 1988.
- . "BGSU Saxophonists to Perform in Italy." *Sentinel-Tribune*, September 2, 1992.
- . "Duo Pianists And Saxophonist To Be Featured At TSO Subscription Concerts." *Toledo Blade*, October 15, 1987.
- . "NMSO In Two Worlds, Premieres Subotnick Work." *Route Sixty-Six Magazine—City Arts*, March 1988.
- . "Review: The Contemporary Saxophone." *The Saxophone Journal*, Vol. 18, No. 3 (November 1993).